



SLAT WALL MOUNTS K1S100 □ DYNAMIC, SINGLE-MONITOR

KONTOUR™ SERIES



FEATURES

- 1 UNIVERSAL COMPATIBILITY**
Flexible design uses OFBU universal bracket for mounting on all slat wall or tool tile systems.
- 2 ULTIMATE FLEXIBILITY**
Dynamic height adjustment using gas-spring technology for ideal positioning.
- 3 FAST INSTALLATION**
Simple 3-step installation and integrated quick-connect interface for easy mounting and maintenance.
- 4 CABLE MANAGEMENT**
Tool-free cable management covers for a clean, professional look.
- 5 CENTRIS® EXTREME TILT PATENTED FEATURE**
Tilts -75°/+10° for an ultimate ergonomic solution.

WHAT YOU NEED TO KNOW

MOUNTING PATTERNS

Compatible with 75 x 75 mm and 100 x 100 mm VESA® patterns.

OTHER PRODUCT OPTIONS



K1S200
Dual Arm Slat Wall Mount

SPECIFICATIONS

Depth from Wall	3.2" (81 mm)
Max. Extension	21" (533 mm)
Tilt	-75° / +10°
Height Assist	13" (330 mm)
Weight Capacity	5–25 lbs (2.3–11.3 kg)
Colors	Black, Silver

RECOMMENDED ACCESSORIES



KRA300 □ Laptop Tray

TECHNICAL DRAWINGS

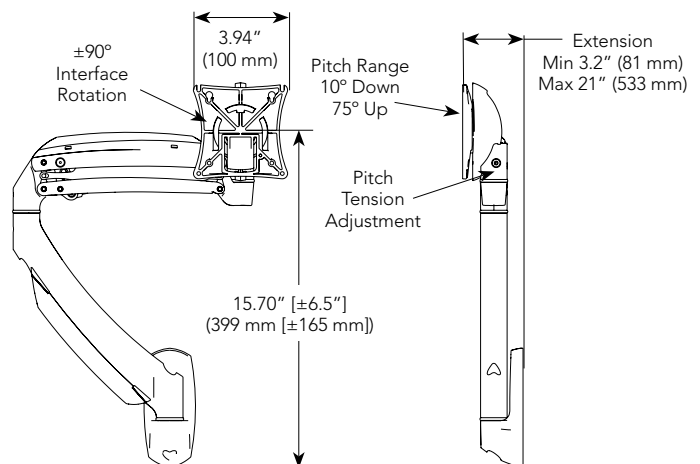

For a complete list of monitor mount accessories see page 123.