



FEATURES

- 1 HEAVY DUTY DESIGN**
Sleek, solidly constructed forged aluminum arms.
- 2 ULTIMATE FLEXIBILITY**
Dynamic height adjustment using gas-spring technology for ideal positioning.
- 3 FAST INSTALLATION**
Simple 3-step installation and integrated quick-connect interface for easy mounting and maintenance.
- 4 CABLE MANAGEMENT**
Tool-free cable management covers for a clean, professional look.
- 5 CENTRIS® EXTREME TILT PATENTED FEATURE**
Tilts -75°/+10° for an ultimate ergonomic solution.



SPECIFICATIONS

| | |
|-----------------|------------------------|
| Depth from Wall | 2.09" (53 mm) |
| Max. Extension | 19.9" (505 mm) |
| Tilt | -75° / +10° |
| Height Assist | 13" (330 mm) |
| Weight Capacity | 5–25 lbs (2.3–11.3 kg) |
| Colors | Black, Silver |

WHAT YOU NEED TO KNOW

MOUNTING PATTERNS

Compatible with 75 x 75 mm and 100 x 100 mm VESA® patterns.

OFFICE FURNITURE SYSTEMS

Compatible with custom and universal Interface Brackets for Office Furniture Systems (OFB)

QUICK-CONNECT INTERFACE

Easily attach and remove interface from mounting head without removing monitor – no tools necessary!



TECHNICAL DRAWINGS

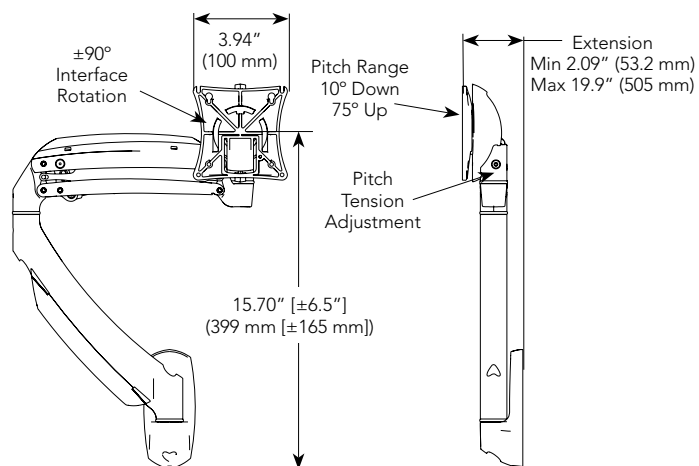

INSTALLATION

