

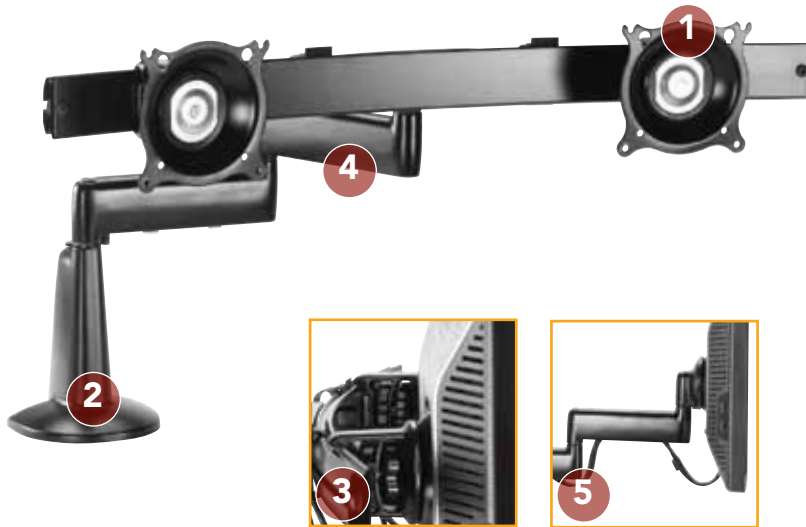

DUAL MONITOR WALL MOUNTS KCD220 ■ DUAL SWING ARM



FEATURES

- 1 CENTRIS® TECHNOLOGY**
PATENTED FEATURE
Provides smooth fingertip tilt in all directions using the screen's center of gravity. Screen angle stays set until you decide to readjust.
- 2 EASY 3-STEP INSTALLATION**
Ships fully assembled, clamp option can be installed from top of desk, grommet bolt through hardware included.
- 3 INDEPENDENT ADJUSTMENT**
Adjust each screen independently for ergonomic alignment.
- 4 ULTIMATE FLEXIBILITY**
Maximum range of motion from low profile to full extension.
- 5 CABLE MANAGEMENT**
Easily route cables through predefined pathway inside arms.

WHAT YOU NEED TO KNOW

INSTALLING THE MONITOR MOUNT

The mounting surface thickness must not exceed 3.2" (81 mm).

OTHER PRODUCT OPTIONS



KCD320
Triple Monitor Swing Arm Desk Mount

SPECIFICATIONS

Depth from Wall	6.4" (163 mm)
Max. Extension	20.5" (521 mm)
Tilt	±15°
Weight Capacity	16.5 lbs (7.5 kg)
Max. Screen Width	22.7" (577 mm)
Grommet size	0.38 - 3" (10 - 76 mm)
Colors	Black, Silver

RECOMMENDED ACCESSORIES



KSA1007 ■ Centris Quick-Connect Interface



KSA1008 ■ Extended Desk Clamp Bracket
– Compatible with 2.5" - 5" (64-127 mm) thick surfaces



KSA1012 ■ Extended Reach Desk Clamp Bracket

TECHNICAL DRAWINGS

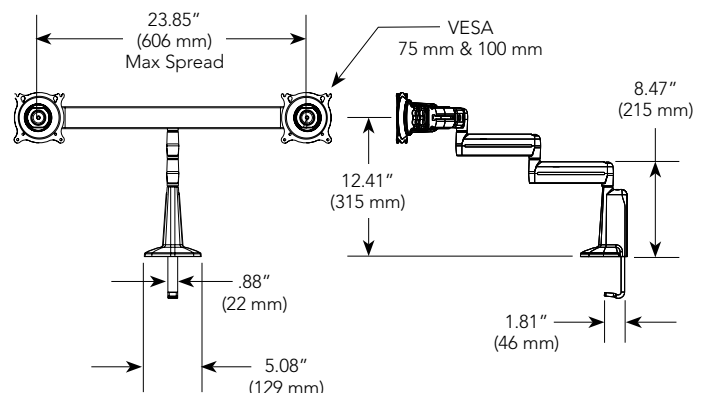

For a complete list of monitor mount accessories see page 123.