



FEATURES

- 1 DROP-IN DESIGN**
Designed to fit 2' x 2' (600mm x 600mm) suspended ceiling systems.
- 2 EASY 3-STEP INSTALLATION**
Installs up to ten times faster than conventional lifts: Suspend frame with WireVice™ cables, snap housing into frame and attach the cradle.
- 3 ONE-PERSON INSTALL**
Made of lightweight aircraft-grade aluminum. The SL220 can be installed by one person using a ladder – no floor lift required.
- 4 QUIET OPERATION**
Moves projector into show or concealed position quickly and quietly.

WHAT YOU NEED TO KNOW

MULTIPLE CONTROL OPTIONS

Choose from single momentary push-button, low-voltage controller and IR options. Also accepts 5-30V AC/DC for triggering commands. AMX/Crestron control compatibility.

VOLTAGE OPTIONS

120V or 230V, current draw of .75 amps

MULTIPLE PROJECTOR MOUNTING OPTIONS

Compatible with Chief RPA, RPMx, RSA & RSMx custom and universal projector mounts (must order separately).

SHIPS FULLY ASSEMBLED



SPECIFICATIONS

Extension	8.5" (216 mm)
Max Projector Size (HxWxD)	9.5 x 16.5 x 18.5" (241 x 419 x 470 mm)
Ceiling Opening	11.52 x 24 x 24" (293 x 600 x 600 mm)
Ceiling Closure	19.3 x 20.7" (489 x 526 mm)
Roll/Pitch/Yaw	Varies (see projector mount specifications)
Weight Capacity	up to 30 lbs (13.6 kg)
Color	White

RECOMMENDED ACCESSORIES



RSMAUW ■ Mini Elite Projector Mount



IR10 ■ Infrared Remote Control

TECHNICAL DRAWINGS

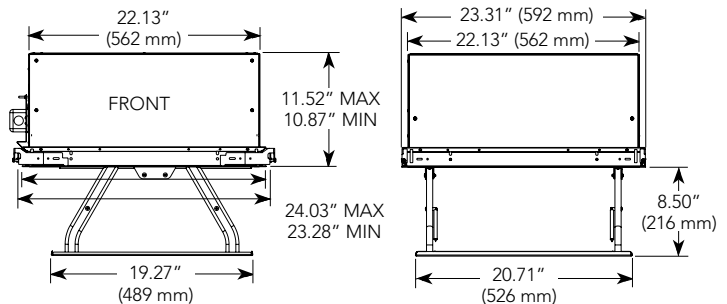

For a complete list of automated projector mount accessories see page 30.