



FEATURES

- 1 INTERACTIVE RECEIVER**
Interactive receiver powered by eBeam Technology adds interactive functionality to any projection-ready surface, and provides up to a 48" - 94" (1.23 m-2.39 m) diagonal projected image.
- 2 FAST INSTALLATION**
Quick-connect system, variable extension, and innovative features make mount installation and registration quick and easy.
- 3 EASY INTEGRATION**
Simply install eBeam's business or education software for Mac or PC, connect computer and projector and you're ready to go.
- 4 INTERACTIVE STYLUS**
Lightweight, ergonomic stylus provides exceptional, real-time rendering capabilities. Includes optional wrist strap.



SPECIFICATIONS

Vertical Adjustment	30 - 54" (76.2 - 137.2 Cm)
Pitch	±3°
Lateral Shift	13" (330 mm)
Weight	25 lbs (11.3 kg)
Color	Silver

WHAT YOU NEED TO KNOW

ORDERING OPTIONS

Available in universal.

RELATED PRODUCTS



WM210AUSI / WM210SI

Interactive Wall Mount Kit / Wall mount accessory
 - Max. extension 0 - 18" (0 - 457 mm)
 - Weight Cap. 50 lbs (22.7 kg)



WM220AUSI / WM220SI

Interactive Wall Mount Kit / Wall mount accessory
 - Max. extension 18-30" (457 - 762 mm)
 - Weight Cap. 50 lbs (22.7 kg)

TECHNICAL DRAWINGS

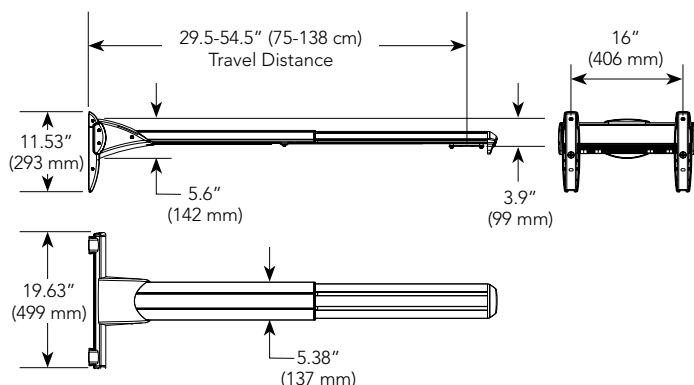

RECOMMENDED ACCESSORIES



WMAL24 ■ 24" (610 mm) Lateral Shift Accessory