

INSTALLATION INSTRUCTIONS

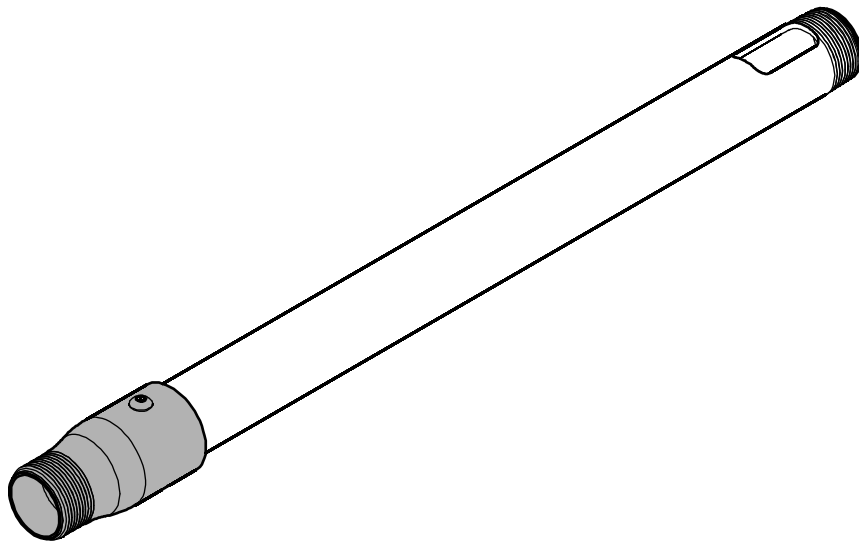

Cut-Off Thread Adapter

DISCLAIMER

Milestone AV Technologies, Inc., and its affiliated corporations and subsidiaries (collectively, "Milestone"), intend to make this manual accurate and complete. However, Milestone makes no claim that the information contained herein covers all details, conditions or variations, nor does it provide for every possible contingency in connection with the installation or use of this product. The information contained in this document is subject to change without notice or obligation of any kind. Milestone makes no representation of warranty, expressed or implied, regarding the information contained herein. Milestone assumes no responsibility for accuracy, completeness or sufficiency of the information contained in this document.

! IMPORTANT WARNINGS AND CAUTIONS!

! WARNING: A WARNING alerts you to the possibility of serious injury or death if you do not follow the instructions.

! CAUTION: A CAUTION alerts you to the possibility of damage or destruction of equipment if you do not follow the corresponding instructions.

! WARNING: Failure to read, thoroughly understand, and follow all instructions can result in serious personal injury, damage to equipment, or voiding of factory warranty! It is the installer's responsibility to make sure all components are properly assembled and installed using the instructions provided.

! WARNING: Exceeding the weight capacity can result in serious personal injury or damage to equipment! It is the installer's responsibility to make sure the combined weight of all components attached to the CMS-260 does not exceed 500 lbs (226.80 kg).

- The weight capacity of the CMS-260 may be LIMITED to the lowest weight capacity of any other component located between the CMS-260 and the supporting structure!

DIMENSIONS

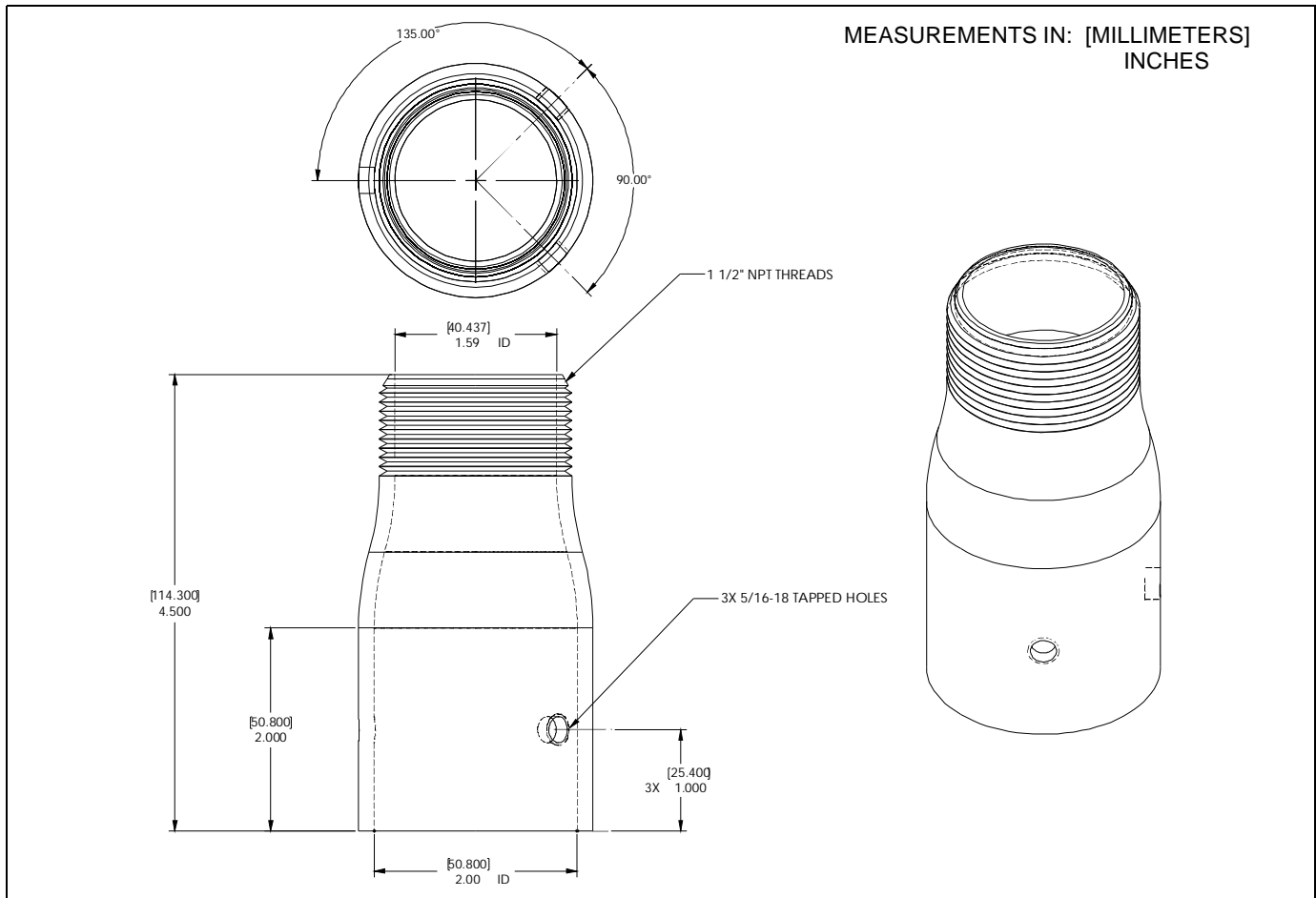

LEGEND

	Tighten Fastener
	Apretar elemento de fijación
	Befestigungsteil festziehen
	Apertar fixador
	Serrare il fissaggio
	Bevestiging vastdraaien
Serrez les fixations	
	By Hand
	A mano
	Von Hand
	Com a mão
	A mano
	Met de hand
À la main	
	Optional
	Opcional
	Optional
	Opcional
	Opzionale
	Optie
En option	

	Security Wrench
	Llave de seguridad
	Sicherheitsschlüssel
	Chave de segurança
	Chiave di sicurezza
	Veiligheidssleutel
Clé de sécurité	
	Hex-Head Wrench
	Llave de cabeza hexagonal
	Sechskantschlüssel
	Chave de cabeça sextavada
	Chiave esagonale
	Zeskantsleutel
Clé à tête hexagonale	

TOOLS REQUIRED and PARTS PROVIDED

<p>5/16"</p>	<p>A (1)</p>
<p>5/32" Security (Provided)</p>	<p>B (1) 5/16 x 1/2"</p>
<p>5/32"</p>	<p>C (1) 5/16 x 1/2" (Security)</p>
	<p>D (2) 5/16 x 1/4"</p>
	<p>E (2) 5/16 x 1/4" (Security)</p>
	<p>F (1) 5/32" (Security)</p>

ASSEMBLING COLUMN

1. Cut off 1-1/2" NPT pipe at desired length.
2. Drill a 5/16" hole 1" from end of pipe. (See Figure 1)

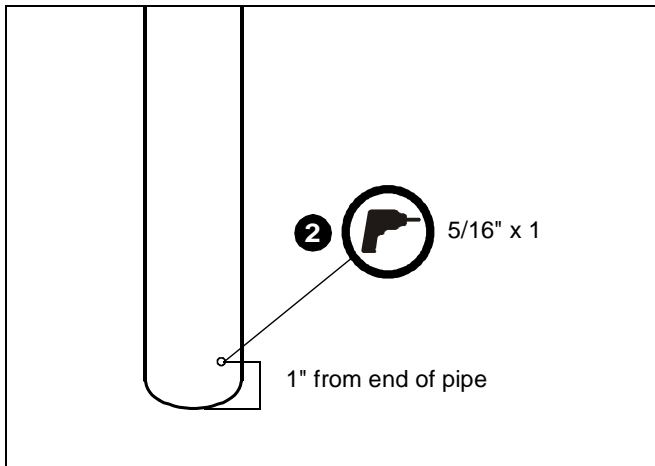

Figure 1

3. Slide CMS-260 (A) onto end of pipe and attach with a 5/16 x 1/2" button head cap screw (B) or 5/16 x 1/2" button head security cap screw (C). (See Figure 2)

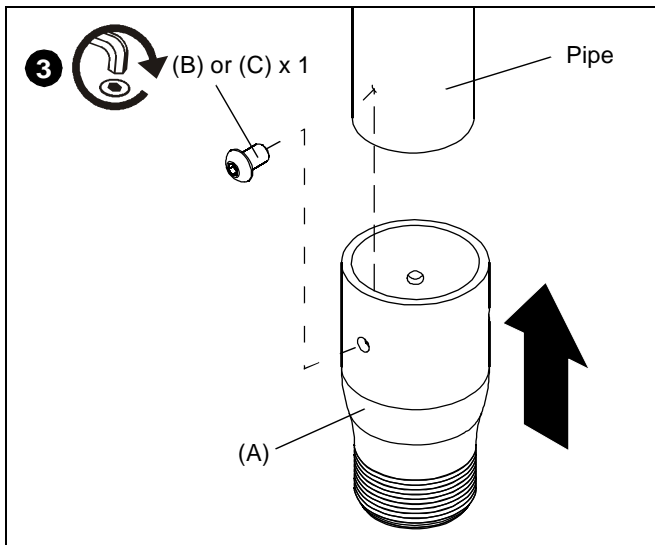

Figure 2

4. Attach and tighten two 5/16 x 1/4" set screws (D) or two 5/16 x 1/4" security set screws (E) into side of CMS-260 (A). (See Figure 3)

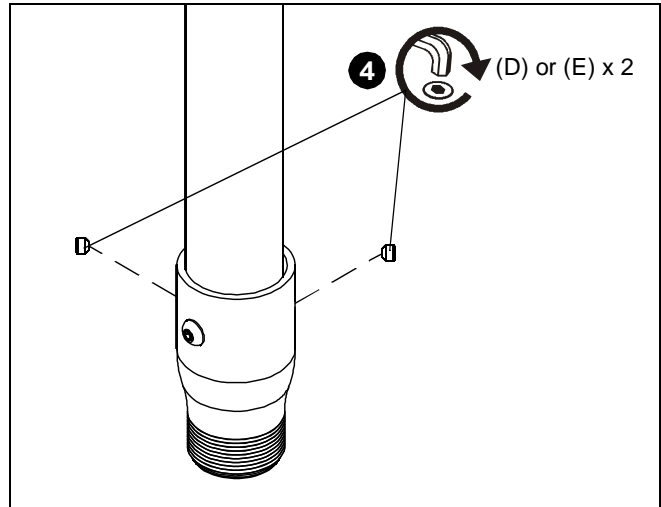

Figure 3

Install the 1-1/2" NPT threaded column with the attached CMS-260 following instructions provided with the column.



8803-000106
©2008 Chief Manufacturing
www.chiefmfg.com
02/08

USA/International	A 8401 Eagle Creek Parkway, Savage, MN 55378 P 800.582.6480 / 952.894.6280 F 877.894.6918 / 952.894.6918
Europe	A Fellenoord 130 5611 ZB EINDHOVEN, The Netherlands P +31 (0)40 2668620 F +31 (0)40 2668615
Asia Pacific	A Room 24F, Block D, Lily YinDu International Building LuoGang, BuJi Town, Shenzhen, CHINA. 深圳市布吉罗岗村百合银都国际大厦D栋24F P +86-755-8996 9226 F +86-755-8996 9217