

# INSTALLATION INSTRUCTIONS

## ELEFUJ50-PRO(L) Mounting Bracket

Prior to assembly, unpack carton completely and verify contents. If you are missing any of the following components, please contact Technical Support at 1-800-776-5768.

- (1) PLASMA STATIC BRACKET
- (4) MOUNTING BUTTONS
- (4) M8-.1.25 X 45MM BHCS
- (4) NYLON SHOULDER WASHERS .805 OD X .324 ID
- (1) M5 ALLEN KEY
- (4) 20 MM NYLON SPACERS
- (4) 10-24 BUTTON HEAD CAP SCREWS
- (4) M8 FLAT WASHERS
- (1) 1/8" ALLEN KEY

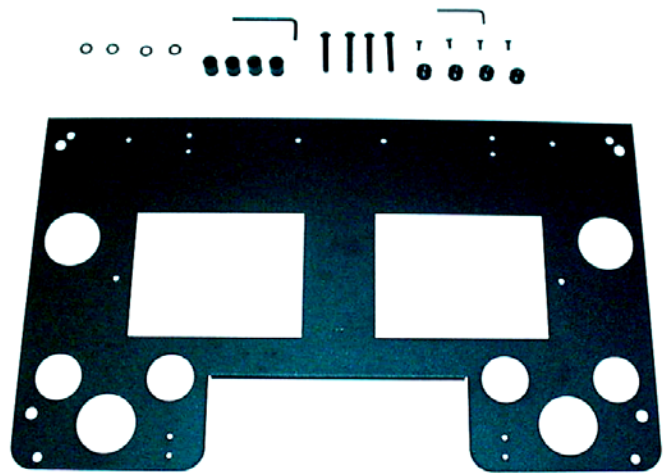

Figure 1

**CAUTION: PLASMA DISPLAYS ARE EXTREMELY FRAGILE!**

**READ INSTALLATION INSTRUCTIONS COMPLETELY  
BEFORE PROCEEDING**

1. Using a 10-24 button head cap screw inserted from the square hole side of bracket, secure mounting button, with chamfered hole of mounting button (larger surface) facing bracket, to bracket (four places). See Figure 2.
2. Place four 20 mm spacers on display over mounting threads in display (see Figure 2).
3. Place display bracket on display (see Figure 2) with bent lip towards the display, place shoulder washers into mounting holes and place M8 flat washers on top of shoulder washer (see Figure 2).
4. Insert M8 bolt and tighten, ensuring not to over tighten.
5. With the aid of another person, lift display up to the mount, aligning buttons of mounting brackets with slots in the mount.
6. Engage safety latches on the mount to secure display; making sure latches are completely engaged.

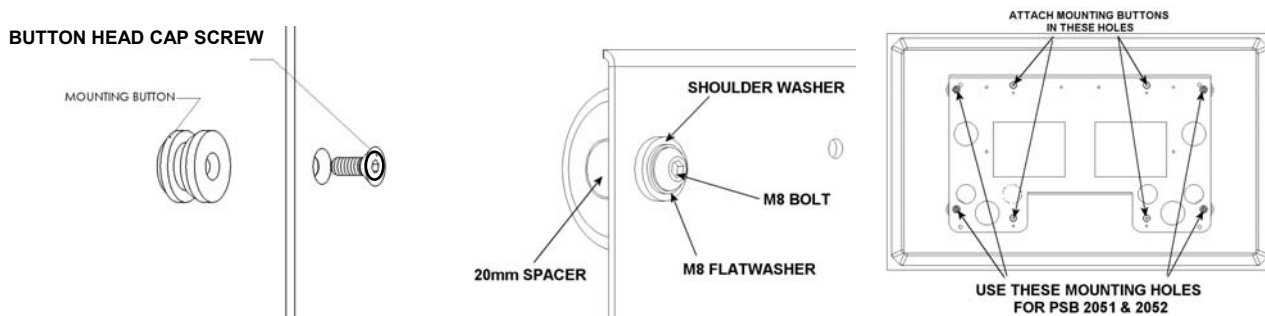

Figure 2