INSTALLATION INSTRUCTIONS

Electrograph Plasma Ceiling Mount (ELESONY32/42-PCM)

The PCM, with Q-latch design, is a quick ceiling installation process that easily attaches to 1 1/2" NPT coupling. A low profile design compliments the sleekness of your plasma while providing versatile sturdy support for your plasma.

With the PCM securely in place, simply use the easy to hang Q-latches to mount your display. Engage the locking device to prevent removal of the display.

Height adjustment (5") and roll adjustment (4° right and left) simplify screen positioning. Optimum viewing is easily achieved using the tilt adjustment (15° down and 5° up).



BEFORE YOU BEGIN

- **CAUTION:** To prevent damage to the PCM, which could affect or void the Factory warranty, and to the equipment that will be attached to it, thoroughly study all instructions and illustrations before you begin the installation. Pay particular attention to the "Important Precautions" on Page 1.
- If you have any questions about this installation, contact Technical Support at 1-800-776-5768.



IMPORTANT WARNINGS AND PRECAUTIONS!

- WARNING:** A **WARNING** alerts you to the possibility of serious injury or death if you do not follow the instructions.
- CAUTION:** A **CAUTION** alerts you to the possibility of damage or destruction of equipment if you do not follow the corresponding instructions.
- **WARNING: Improper installation can result in serious personal injury! Make sure that the ceiling structural members can support a redundant weight factor *five times* the total weight of the equipment: if not, reinforce the ceiling before installing the suspended ceiling kit.**
 - **WARNING: Be aware also of the potential for personal injury or damage to the unit if it is not adequately mounted.**
 - **WARNING: The installer is responsible for verifying that the ceiling to which the PCM's reinforcing plate is anchored will safely support the combined load of all attached components or other equipment.**
 - **WARNING: The combined weight of the plasma display panel must not exceed 200 lbs (90.72 kg), the maximum load capacity of the reinforcing plate.**
 - **CAUTION:** Check the unit for shipping damage before you begin the installation.

CONTENTS

TOOLS REQUIRED FOR INSTALLATION	1
DIMENSIONAL DRAWING	2
ASSEMBLY PROCEDURE	3
MOUNTING PROCEDURES	3
ADJUSTMENTS	4
PARTS	5

TOOLS REQUIRED FOR INSTALLATION

- Pipe wrench
- 5/16" Allen Wrench
- 1/2" wrench
- Other tools may be required depending on the method of installing the unit in the ceiling.

DIMENSIONAL DRAWING

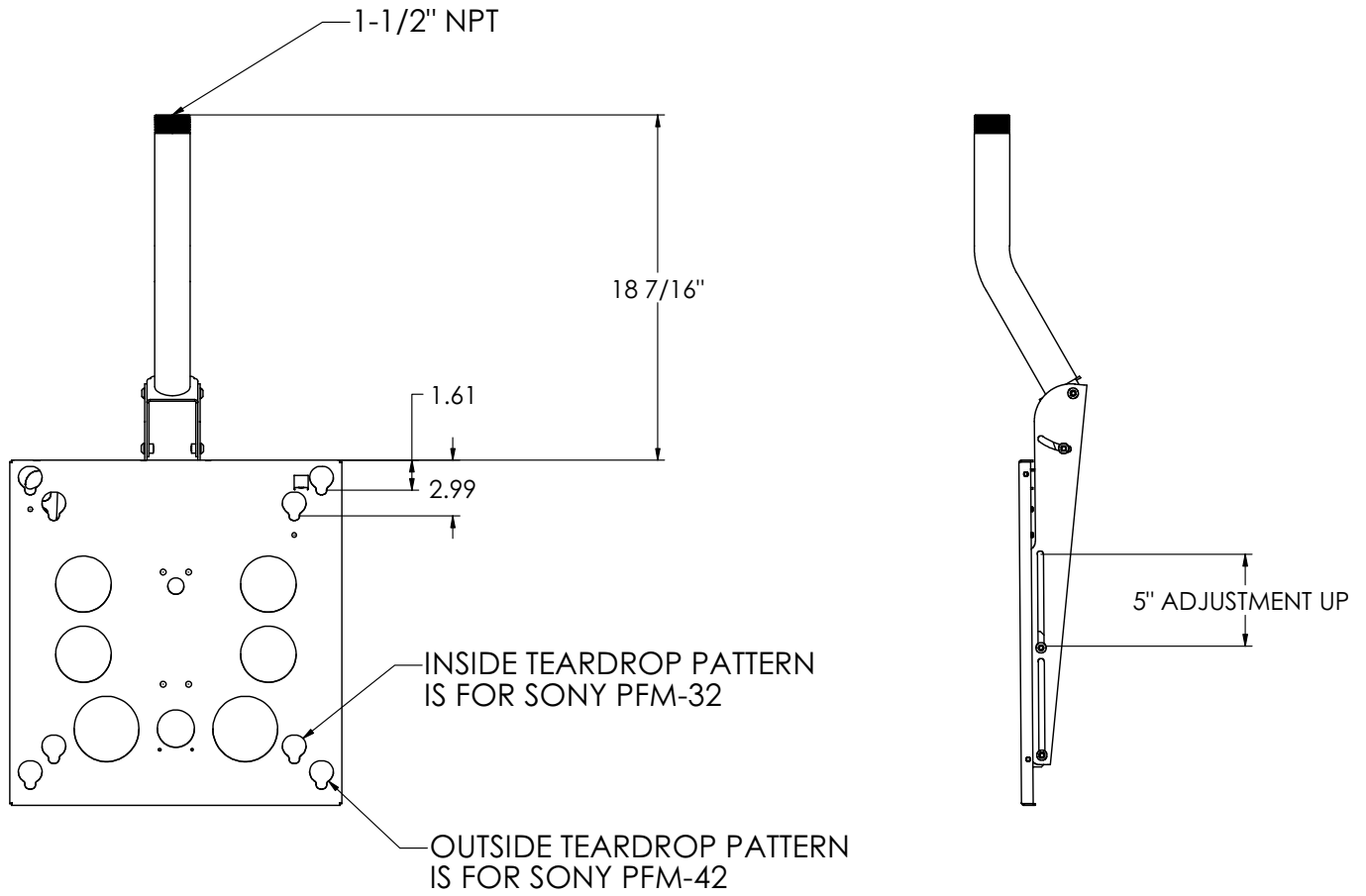

ASSEMBLY PROCEDURE

1. Remove two adjustment screws that are not securing the tube and open the PCM body assembly by raising the tube, pivoting it on the tilt adjustment screws (see Figure 1).
2. Secure the tube using the two adjustment screws removed in step 1.
3. Using four 5/16-18 button head cap screws and four washers, secure the PCM body to the PCM plate assembly (see Figure 2).

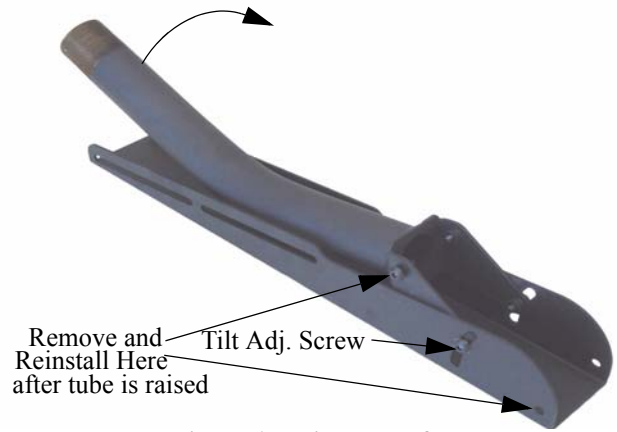

Figure 1. Raise tube of Body

MOUNTING PROCEDURES

WARNING: Improper installation can cause serious personal injury! Make sure that the ceiling structural members can support a redundant weight factor *five times* the total weight of the entire mounting assembly with the equipment you intend to support overhead. The ceiling must be reinforced before you install the PCM if the ceiling cannot support a redundant weight factor *five times* the total weight of the mounting assembly and the equipment.

1. Thread the PCM onto the 1 1/2" NPT pipe extension/coupling you have provided.
2. Make sure the mount is level (see ADJUSTMENTS, Roll) and latch is positioned so it will not obstruct plasma installation (see Figure 3).
3. With one person supporting each side of the display, align the four Q-latches with the four openings.
4. Secure the display by completely engaging the latch.
5. Lock the display in place by installing two Q-clamps on each side of the bottom of face plate as shown in Figure 4.
6. Connect and secure power/audio/video cables.

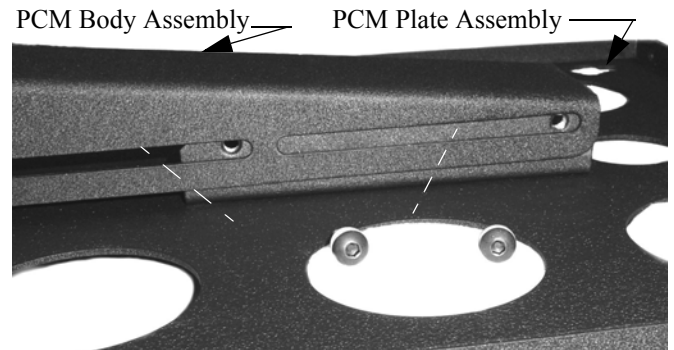

Figure 2. Assemble Body to Plate

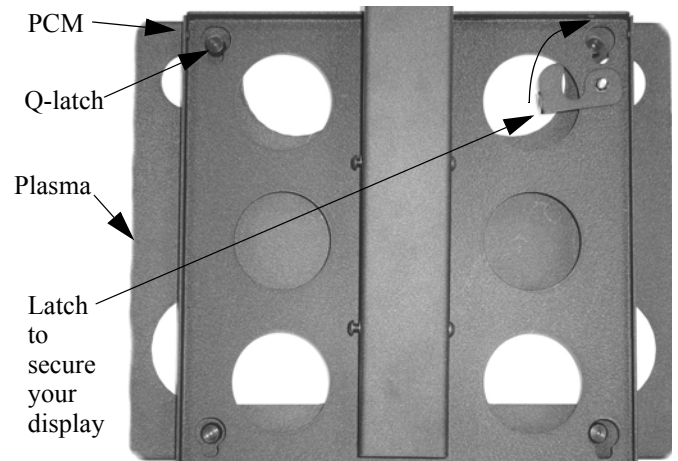

Figure 3. Mounting

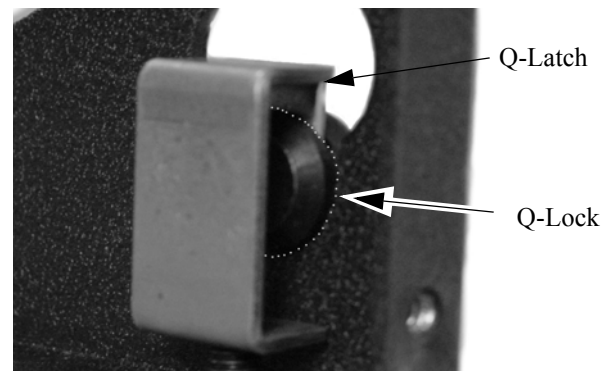

Figure 4. Install Q-Locks

ADJUSTMENTS

Height

1. Loosen four 5/16-18 button head cap screws (see Figure 5).
2. Adjust the height to the desired position.
3. Tighten the four 5/16-18 button head cap screws.

Roll

1. Loosen the four 5/16-18 Nylock nuts (see Figure 6).
2. Adjust the roll, using the slotted bottom holes, to the desired position.
3. Tighten the four 5/16-18 Nylock nuts.

Tilt

1. Loosen the four 5/16-18 button head cap screws (see Figure 7).
2. Adjust to the desired tilt position.
3. Tighten the four 5/16-18 button head cap screws.

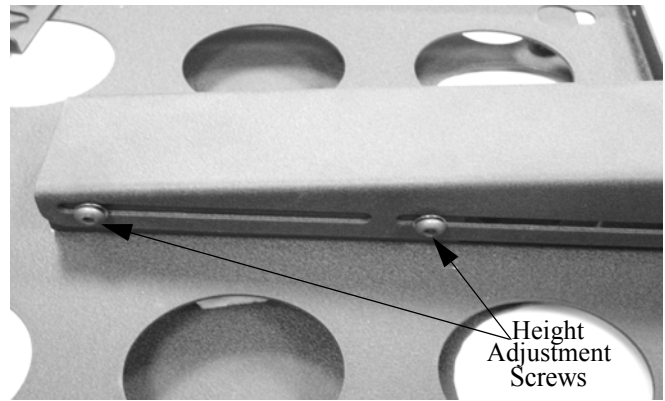

Figure 5. Height Adjustment

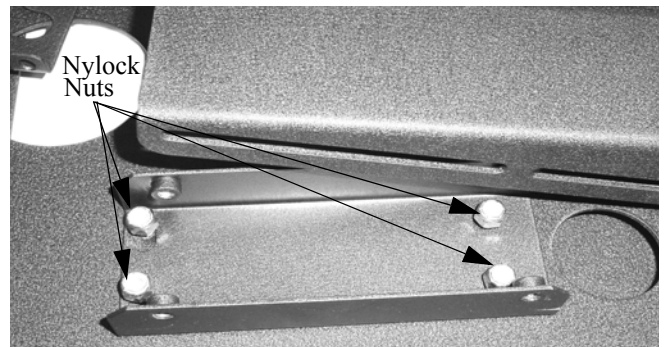

Figure 6. Roll Adjustment

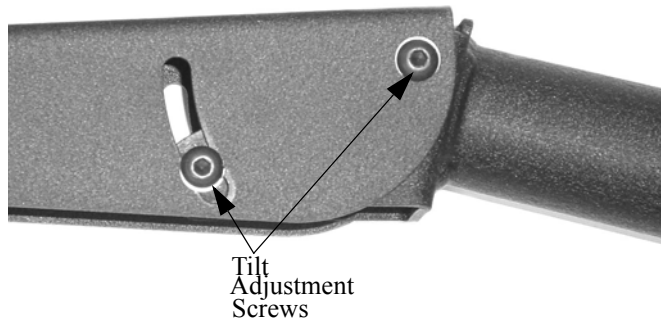

Figure 7. Tilt Adjustment

PARTS

Table 1:

Item	Description	Qty
1	Screw, Cap, Button Head	8
2	Nut, Hex, .3125 X 18	4
3	Washer, Stainless Steel	3
4	Nut, Lock, LP	1
5		
6	Plate, Front	1
7	Knob, Latch	1
8	Tube, 1 1/2" Threaded	1
9	Mount, Pitch	1
10	Adapter, Mount, Pitch	1
11		
12	Buckle, Spud	2

