

INSTALLATION INSTRUCTIONS

DISPLAY STATIC MOUNT FSB-4224

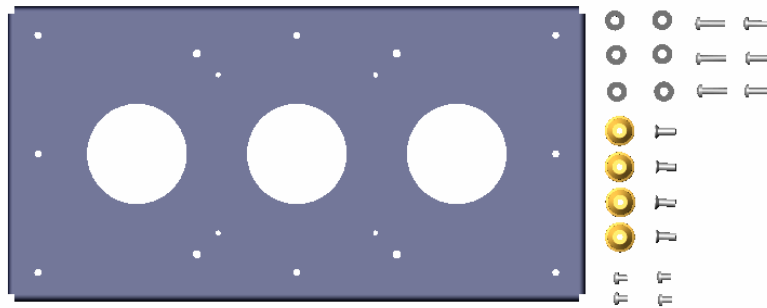

Figure 1

- | | |
|--|---|
| (1) FSB Mount | (4) Mounting Buttons |
| (6) M4 x 25mm Phillips Pan Head Screws | (4) 10-24 x .5 Flat Head Undercut Screw |
| (6) .50"OD x .22"ID x .25"L Nylon Spacer | (4) M4 x 6mm Phillips Pan Head Screws |

BEFORE PROCEEDING: Unpack the carton, verify contents shown in Figure 1 and read installation instructions completely. If you are missing any of the listed components, please contact Customer Service at 1-800/582-6480.

CAUTION! Displays are Extremely Fragile.

Interface installation

1. If used with any small flat screen system using Chief Manufacturing's Q2 (5" x 5") mounting system.

- 1a. Assemble four (4) mounting buttons to 5" hole pattern on the adapter bracket using four (4) 10-24 x .50" Phillips pan head screws (see Figure 2).
- 2a. Assemble six (6) M4 x 25mm Phillips pan head screws and six (6) Nylon spacers (see Figure 3).

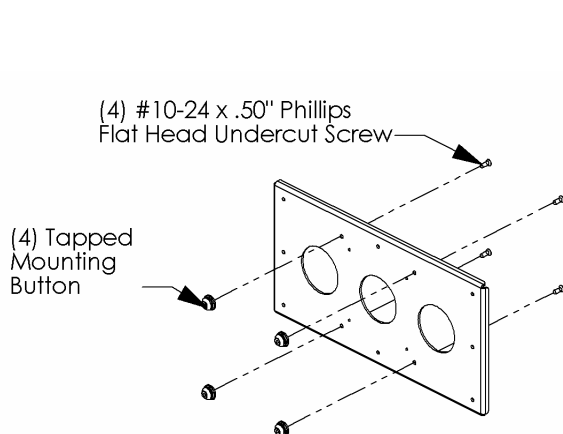

Figure 2

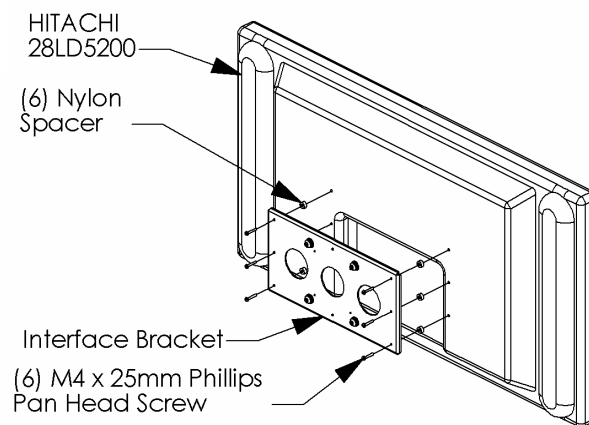

Figure 3



CHIEF MANUFACTURING INC.
1-800-582-6480 952-894-6280 FAX 952-894-6918
8401 EAGLE CREEK PKWY, STE. 700
SAVAGE, MINNESOTA 55378 USA

8804-000200 REV. B
2004 Chief Manufacturing
www.chiefmfg.com
03/05

2. Optional VESA Mounting

1b. Assemble six (6) M4 x 25mm Phillips pan head screws and six (6) Nylon spacers (see Figure 4).

2b. Using four inside tapped holes of interface bracket and M4 x 6mm Phillips Screws (provided), secure adapter bracket to any mounting device using a 100mm x 100mm VESA pattern. (see Figure 5)

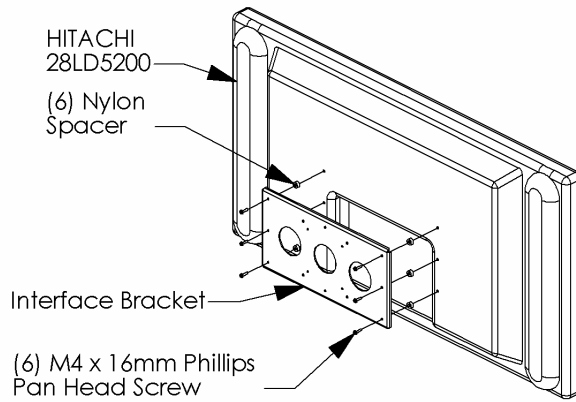

Figure 4

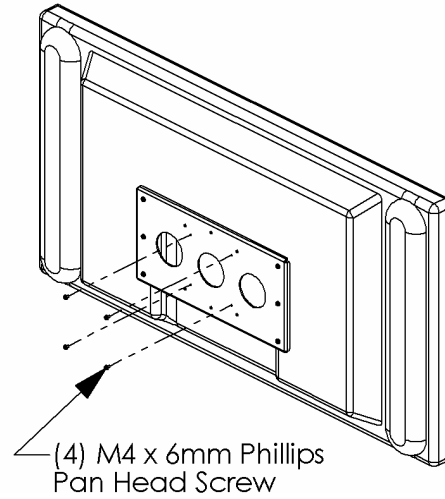

Figure 5