INSTALLATION INSTRUCTIONS

SMALL FLAT PANEL DISPLAY MOUNTING BRACKET

FSB-4227

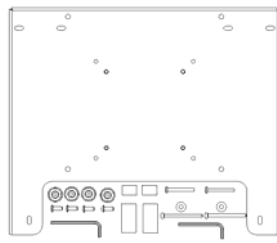

Figure 1

- | | |
|---------------------------------------|--|
| (1) FSB Interface Bracket | (4) Mounting Buttons |
| (4) 10-24 x .5 Button Head Cap Screw | (2) .75 x .34 x .50 Nylon Spacer - White |
| (2) M4 x 35mm Phillips Head Cap Screw | (2) .74 x .48 x 1.5 Nylon Spacer - Black |
| (2) M4 x 50mm Socket Head Cap Screw | (2) #10 Flat Washer |
| (1) 1/8 Allen Key | (1) M3 Allen Key |

BEFORE PROCEEDING: Unpack the carton, verify contents shown in Figure 1 and read installation instructions completely. If you are missing any of the listed components, please contact Customer Service at 1-800/582-6480.

CAUTION!

Displays are Extremely Fragile.

NOTE: If installing screen onto a VESA 100mm X 100mm mount, skip to step 2 on Page 2 (mounting button installation is not required).

1. Using #10-24 screws secure mounting button to bracket, with chamfered hole of mounting button (larger surface) facing bracket (4 places) (see Figure 2 and Figure 3).

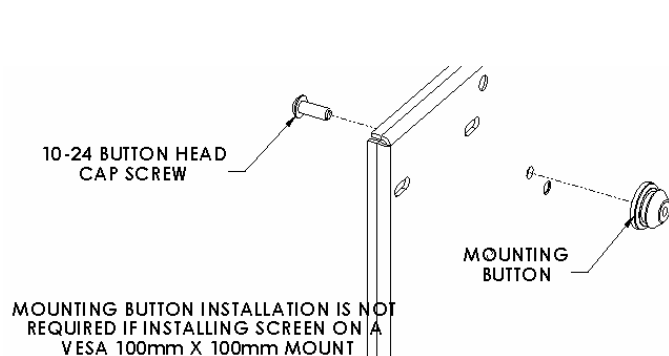

Figure 2

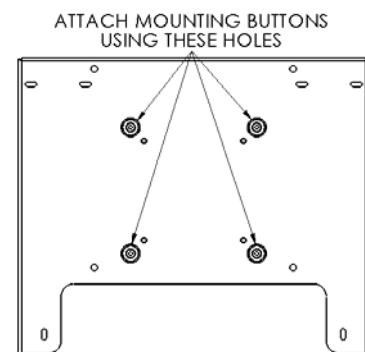

Figure 3



CHIEF MANUFACTURING INC.
1-800-582-6480 952-894-6280 FAX 952-894-6918
8401 EAGLE CREEK PKWY, STE. 700
SAVAGE, MINNESOTA 55378 USA

8804-000225 REV. B
2005 Chief Manufacturing
www.chiefmfg.com
12/05

WARNING!

ALL COMPONENTS MUST BE SECURELY FASTENED TO A STRUCTURAL MEMBER CAPABLE OF SUPPORTING 4 TIMES THE COMBINED WEIGHT OF ALL COMPONENTS PLUS THE EQUIPMENT BEING MOUNTED. IF IT CANNOT SUPPORT THIS WEIGHT, THE STRUCTURE MUST BE REINFORCED. THE MAXIMUM WEIGHT TO BE INSTALLED ON THE BRACKET IS 45 POUNDS (20.41 KG).

2. Remove screws from upper mounting holes on back of display. Place white nylon spacers on upper mounting holes and black nylon spacers on lower mounting holes, aligning hole pattern on brackets with pattern on back of display (see Figure 3 and Figure 4).

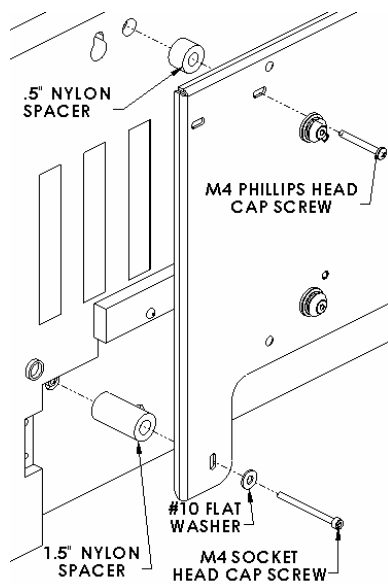

Figure 3

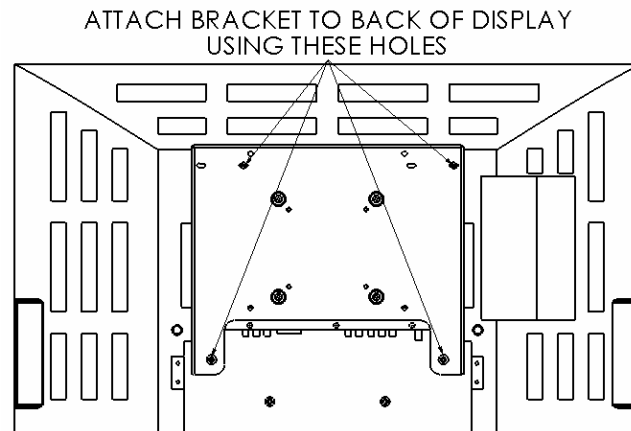

Figure 4

3. Using the M4 x 35mm screws on upper mounting holes and M4 x 50mm screws with #10 flat washers on lower mounting holes, secure bracket to display. Do not over tighten screws.
4. **For Chief Q2™ mounts with 5" X 5" Mounting System** - With the aid of another person, lift the display up to the mount, align the mounting buttons on the plasma with the slots in the mount, and set the screen into place. Lower safety latch on the Chief Mount to secure your display, making sure latch is completely engaged.
5. **For VESA 100mm X 100mm Mounting Systems** - With the aid of another person, lift display up to the mount, align threaded holes of interface bracket to mounting holes of mount. Attach screen to mount (per mount instructions) with M4 screws provided with mount.