

---

# INSTALLATION INSTRUCTIONS

---

## SMALL FLAT PANEL DISPLAY MOUNTING BRACKET FSB-4235

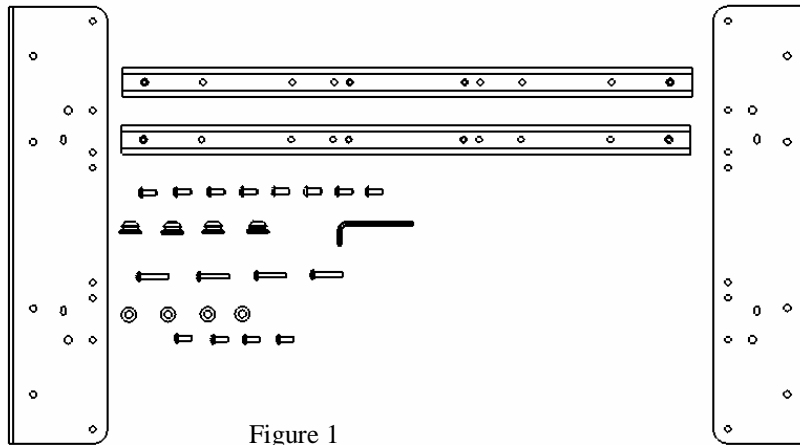

Figure 1

- (2) Interface Side Brackets
- (4) M4 x 35mm Phillips Head Cap Screws
- (8) 10-24 x .5" Button Head Cap Screws
- (4) M4 x 12mm Phillips Head Cap Screws

- (2) Interface Center Brackets
- (4) .500 x .257 x .625 Nylon Spacers
- (4) Q2 Mounting Buttons, tapped
- (1) 1/8" Hex Key

**BEFORE PROCEEDING:**     Unpack the carton, verify contents shown in Figure 1 and read installation instructions completely. If you are missing any of the listed components, please contact Customer Service at 1-800/582-6480.

**CAUTION!**     Displays are Extremely Fragile.

**WARNING!**     **ALL COMPONENTS MUST BE SECURELY FASTENED TO A STRUCTURAL MEMBER CAPABLE OF SUPPORTING 4 TIMES THE COMBINED WEIGHT OF ALL COMPONENTS PLUS THE EQUIPMENT BEING MOUNTED. IF IT CANNOT SUPPORT THIS WEIGHT, THE STRUCTURE MUST BE REINFORCED. THE MAXIMUM WEIGHT TO BE INSTALLED ON THE BRACKET IS 45 POUNDS (20.41 KG).**



**CHIEF MANUFACTURING INC.**  
1-800-582-6480 952-894-6280 FAX 952-894-6918  
8401 EAGLE CREEK PKWY, STE. 700  
SAVAGE, MINNESOTA 55378 USA

8835-000002 REV A  
2006 Chief Manufacturing  
[www.chiefmfg.com](http://www.chiefmfg.com)  
09/06

## A. Small flat screen systems using Chief Manufacturing's Q2™ (5" x 5) mounting system

- Using #10-24 screws secure mounting button (hex key provided), with chamfered hole of mounting button (larger surface) facing bracket, to bracket (4 places) (see Figure 2 and Figure 3).

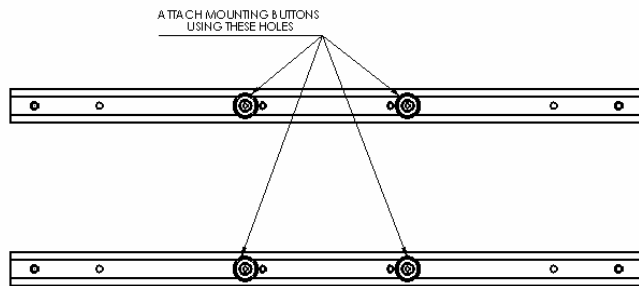

Figure 2

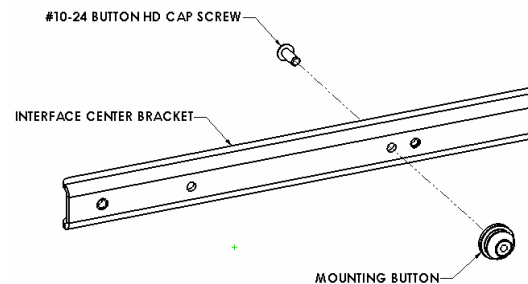

Figure 3

- Attach center brackets to side brackets using #10-24 screws, hex key provided. (see Figure 4 & Figure 5).

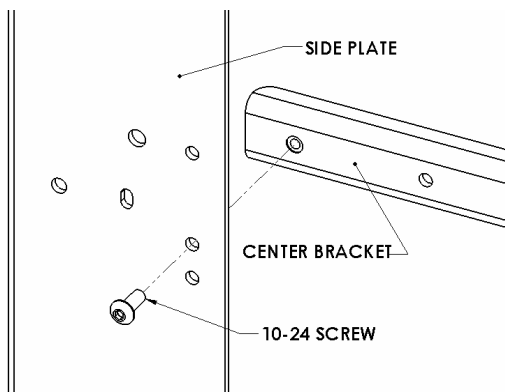

Figure 4

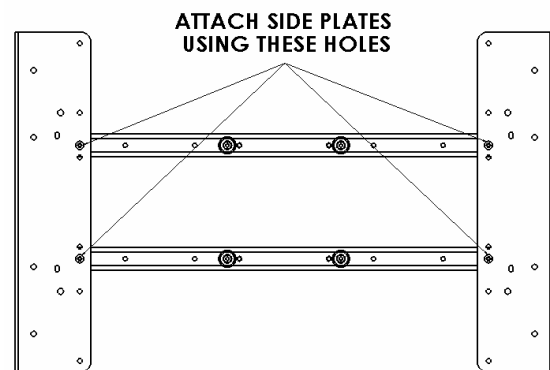

Figure 5

- Place Nylon spacers on mounting holes, aligning hole pattern on *side* brackets with pattern on back of display (see Figure 6 and Figure 7).

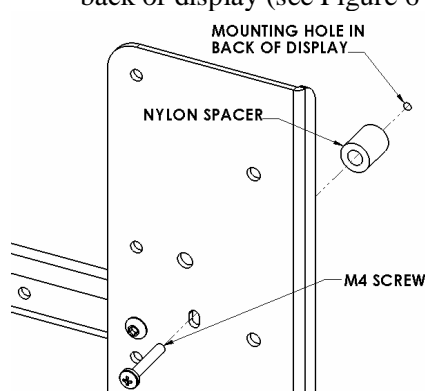

Figure 6

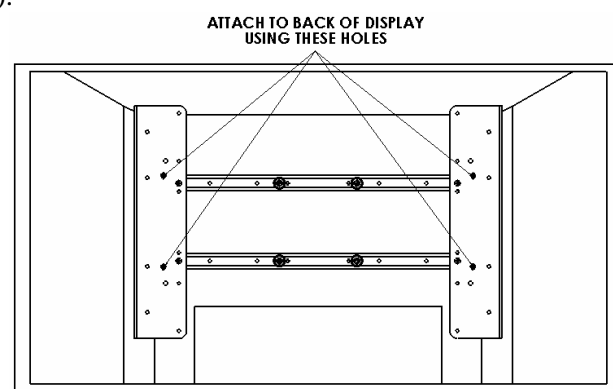

Figure 7

- Using M4 X 35mm Phillips head screws, secure side brackets to display. Do not over tighten screws.
- With the aid of another person, lift display up to the Chief Mount, aligning buttons of mounting brackets with slots in the Chief Mount.
- Lower safety latch on the Chief Mount to secure your display, making sure latch is completely engaged.

## B. Small flat screen systems requiring a 100mm x 100mm VESA mounting pattern

1. Attach center brackets to side brackets using #10-24 screws, hex key provided. (see Figure 8 and Figure 9).

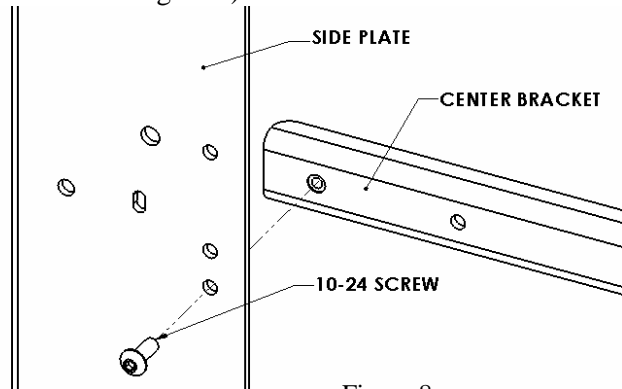

Figure 8

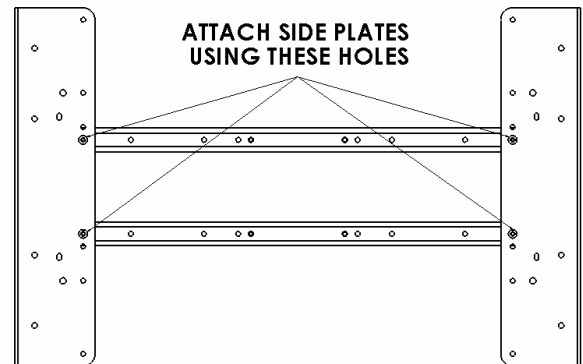

Figure 9

2. Place Nylon spacers on mounting holes, aligning hole pattern on *side* brackets with pattern on back of display (see Figure 10 & Figure 11).

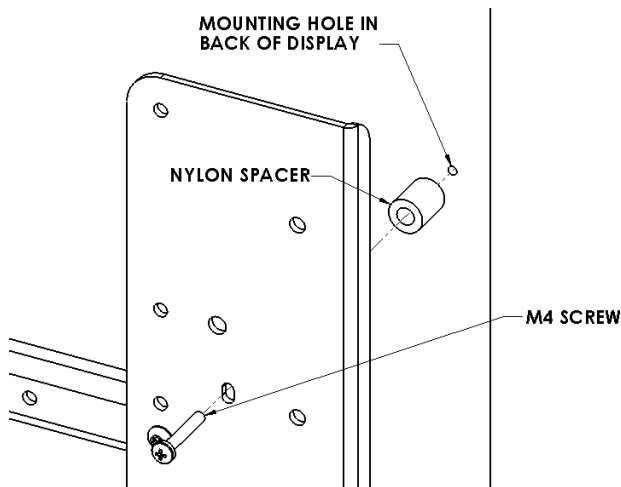

Figure 10

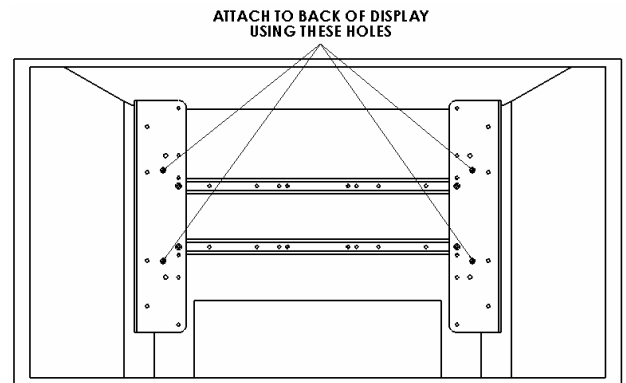

Figure 11

3. Using M4 X 35mm Phillips head screws, secure side brackets to display. Do not over tighten screws.
4. Use the 100mm x 100mm VESA and four M4 X 12mm screws to attach display to mount.