

INSTALLATION INSTRUCTIONS

MSB-6055 DISPLAY MOUNTING BRACKET

Prior to assembly, unpack carton completely and verify contents.

If you are missing any of the following components, please contact Customer Service at 1-800/582-6480

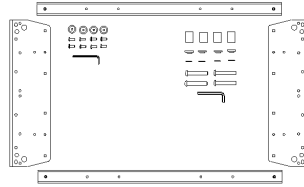

Figure 1

- (2) Interface Side Brackets
- (4) Mounting Buttons – Black Nylon
- (4) .50 x .26 x .1875 Nylon Spacers
- (8) 10-24 Button Head Cap Screws
- (4) .74 x .39 x 1.0 Nylon Spacers
- (4) Nylon Shoulder Washers
- (1) M5 Allen Key

- (2) Interface Center Brackets
- (4) 10-24 x 1.5 Phillips Head Cap Screws
- (4) 10-24 Nylock Nuts
- (4) M8 x 60mm Button Head Cap Screws
- (4) M8 Flat Washers
- (1) 1/8" Allen Key

BEFORE PROCEEDING, READ INSTALLATION INSTRUCTIONS COMPLETELY

CAUTION! DISPLAYS ARE EXTREMELY FRAGILE.

WARNING! ALL COMPONENTS MUST BE SECURELY FASTENED TO A STRUCTURAL MEMBER CAPABLE OF SUPPORTING 4 TIMES THE COMBINED WEIGHT OF ALL COMPONENTS PLUS THE EQUIPMENT BEING MOUNTED. IF IT CANNOT SUPPORT THIS WEIGHT, THE STRUCTURE MUST BE REINFORCED. THE MAXIMUM WEIGHT TO BE INSTALLED ON THE INTERFACE IS 125 POUNDS (79.38 KG).

NOTE: If installing screen on a Chief J-series wall mount, proceed to Step 3 (J-Series VESA Interface Installation).

1. **Chief Q-latch Button Installation (Used with MSR, MTR, MWH, MWR, MCS and MCD mounts):**
Using a 10-24 phillips head cap screw, .1875" nylon spacer and 10-24 nylock nut secure nylon mounting button to center brackets (four places) (see Figure 2 & Figure3).
2. Proceed to Step 4 (Side Bracket Assembly).

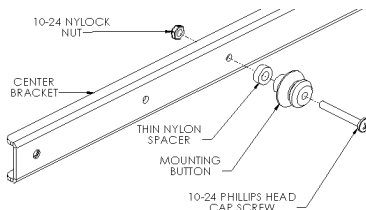

Figure 2

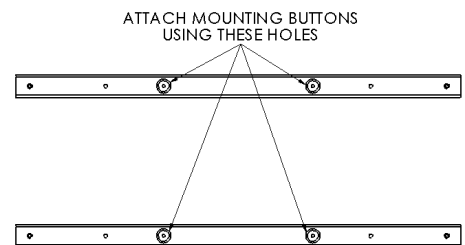

Figure 3

3. **J-Series VESA Interface Installation:** Using the 10-24 button head cap screws along with the 10-24 Nylock nuts (provided with J-Series mount), attach VESA interface from J-Series mount to center brackets (see Figure 4 & Figure 5).

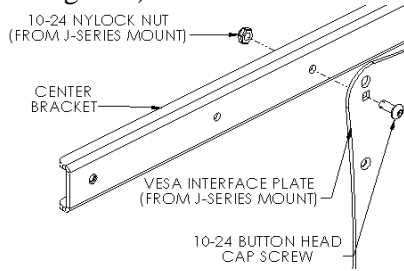

Figure 4

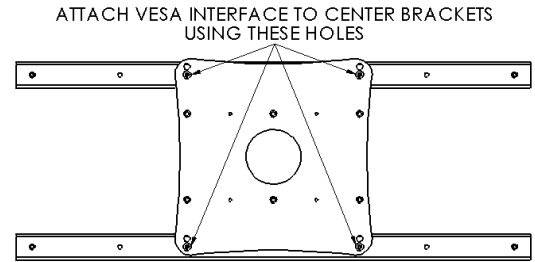

Figure 5

4. **Side Bracket Assembly:** Attach center brackets to side brackets using the 10-24 button head cap screws (see Figure 6 & Figure 7).

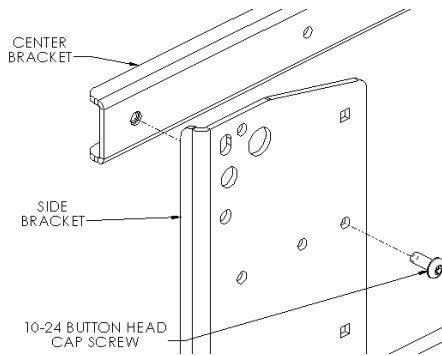

Figure 6

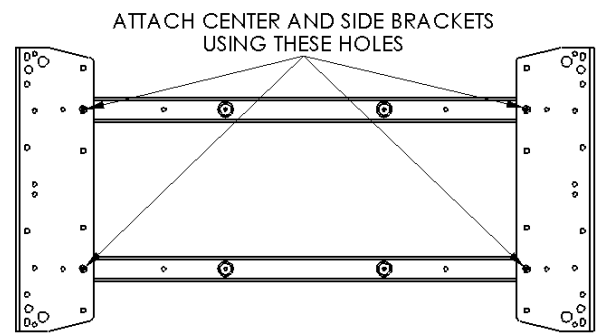

Figure 7

5. **Bracket Installation:** Place nylon spacers over mounting holes on back of screen. Attach mounting brackets to display using the M8 screws, shoulder and steel washers (see Figure 8 & Figure 9). Do not over tighten screws.
6. Follow the Chief mount instruction manual for screen installation.

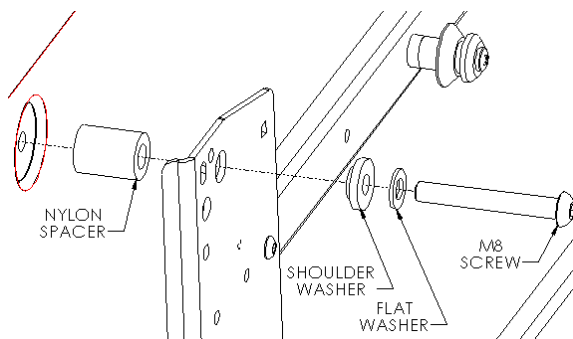

Figure 8

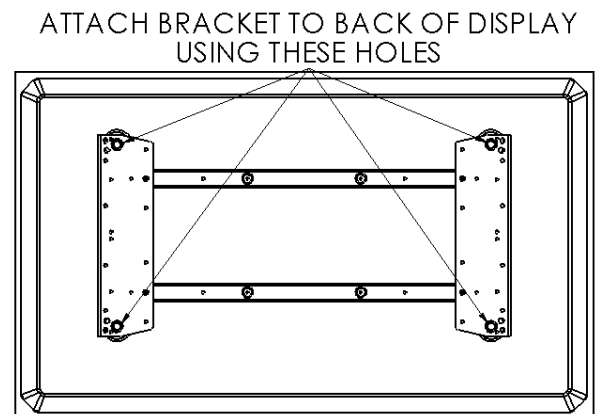

Figure 9