

INSTALLATION INSTRUCTIONS

MSB-6056 & 6057 DISPLAY MOUNTING BRACKET

Prior to assembly, unpack carton completely and verify contents.

If you are missing any of the following components, please contact Customer Service at 1-800/582-6480

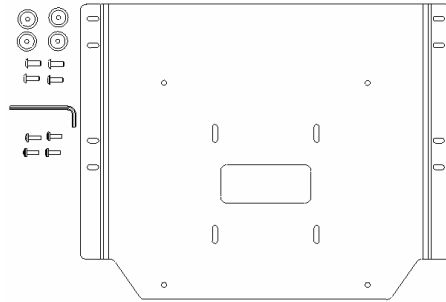

Figure 1

(1) Interface Bracket

(4) 10-24 x .5 Button Head Cap Screw

(1) 1/8" Allen Key

(4) Mounting Button - Tapped

(4) M4 x 12 Phillips Head Cap Screw

BEFORE PROCEEDING, READ INSTALLATION INSTRUCTIONS COMPLETELY

CAUTION! DISPLAYS ARE EXTREMELY FRAGILE.

WARNING! ALL COMPONENTS MUST BE SECURELY FASTENED TO A STRUCTURAL MEMBER CAPABLE OF SUPPORTING 4 TIMES THE COMBINED WEIGHT OF ALL COMPONENTS PLUS THE EQUIPMENT BEING MOUNTED. IF IT CANNOT SUPPORT THIS WEIGHT, THE STRUCTURE MUST BE REINFORCED. THE MAXIMUM WEIGHT TO BE INSTALLED ON THE INTERFACE IS 125 POUNDS (79.38 KG).

NOTE: If installing screen on a Chief J-series wall mount, proceed to Step 3 (J-Series VESA Interface Installation).

1. **Chief Q-latch Button Installation (Used with MSR, MTR, MWH, MWR, MCS and MCD mounts):** Using a 10-24 button head cap screw inserted from back side of bracket, secure mounting button, with chamfered hole of mounting button (larger surface) facing bracket, bracket (four places) (see Figure 2 & Figure3).
2. Proceed to Step 4 (Bracket Installation).

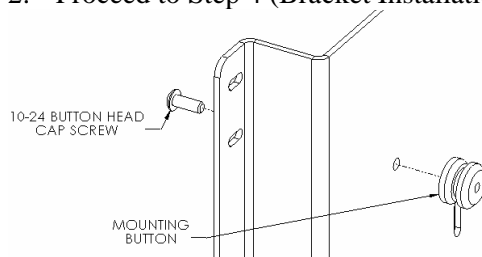

Figure 2

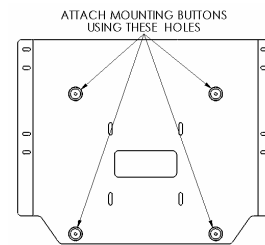

Figure 3

3. **J-Series VESA Interface Installation:** Using the 10-24 button head cap screws along with the 10-24 Nylock nuts (provided with J-Series mount), attach VESA interface from J-Series mount to MSB bracket (see Figure 4 & Figure 5).

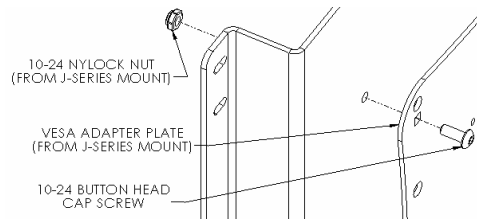

Figure 4

ATTACH VESA INTERFACE PLATE TO BRACKET
USING THESE HOLES

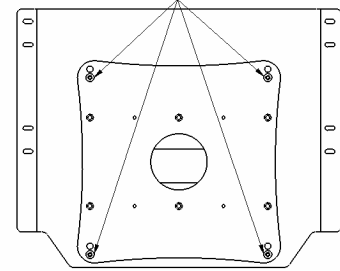

Figure 5

4. **Bracket Installation:** Attach bracket to back of display using the M4 x 12mm screws, making sure to use the correct slots for each screen size (see Figure 6 & Figure 7 for 32" and Figure 8 & Figure 9 for 26" screen).
5. Follow the Chief mount instruction manual for screen installation.

32" Screen Bracket Attachment

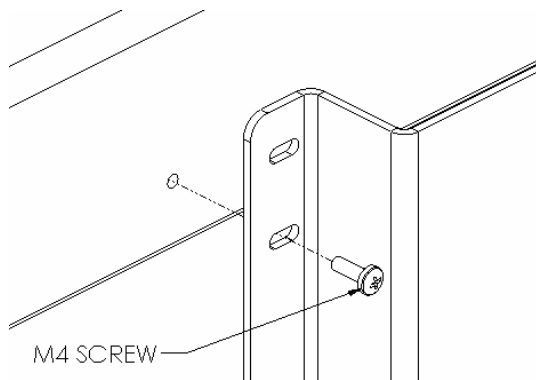

Figure 6

ATTACH BRACKET TO BACK OF DISPLAY
USING THESE HOLES

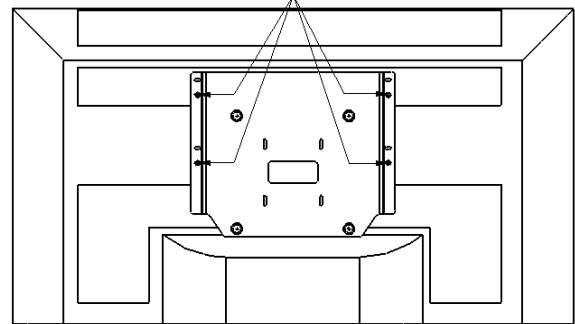

Figure 7

26" Screen Bracket Attachment

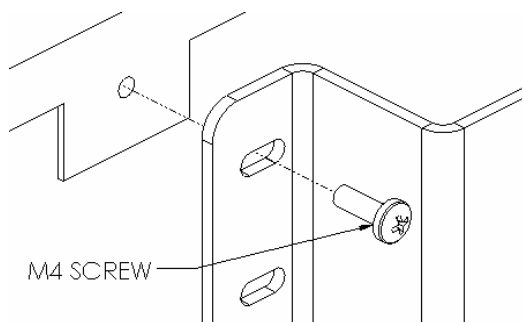

Figure 8

ATTACH BRACKET TO BACK OF DISPLAY
USING THESE HOLES

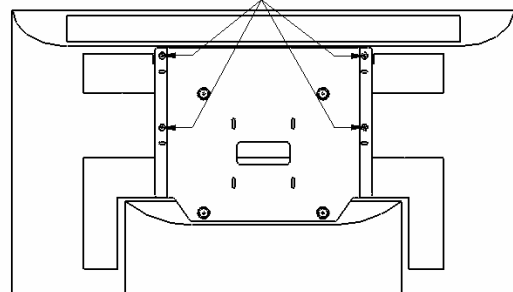

Figure 9