

INSTALLATION INSTRUCTIONS

MSB-6118 DISPLAY MOUNTING BRACKET

Prior to assembly, unpack carton completely and verify contents.

If you are missing any of the following components, please contact Customer Service at 1-800/582-6480

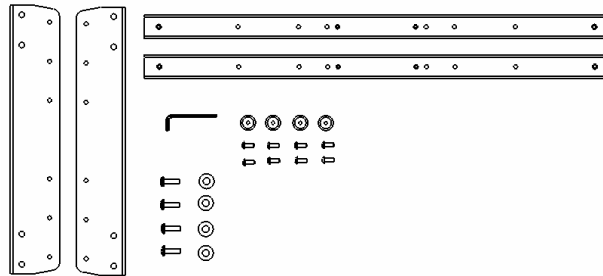

Figure 1

- (2) Interface Side Brackets
- (4) Mounting Buttons – Tapped
- (4) M6 x 25mm Phillips Head Cap Screws
- (1) 1/8" Allen Key

- (2) Interface Center Brackets
- (8) 10-24 x .500 Button Head Cap Screws
- (4) .750 x .344 x .500 Nylon Spacers

BEFORE PROCEEDING, READ INSTALLATION INSTRUCTIONS COMPLETELY

CAUTION! DISPLAYS ARE EXTREMELY FRAGILE.

NOTE: If installing screen on a Chief J-series wall mount, proceed to Page 3 (J-Series VESA Interface Installation).

1. Chief Q-latch Button Installation (Used with M-series mounts):

Using a 10-24 button head cap screw inserted from back side of bracket, secure mounting button, with chamfered hole of mounting button (larger surface) facing bracket, to center brackets (four places) (see Figure 2 & Figure 3).

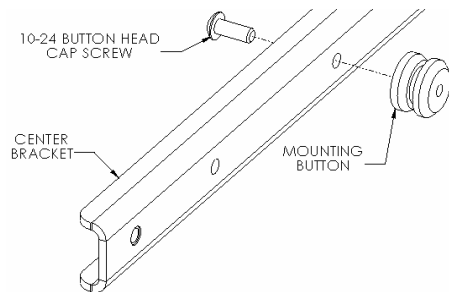

Figure 2

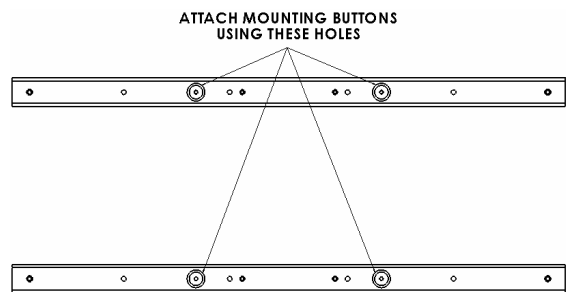

Figure 3

2. **Side Bracket Assembly:** Attach center brackets to side brackets using the 10-24 button head cap screws (see Figure 4 & Figure 5).

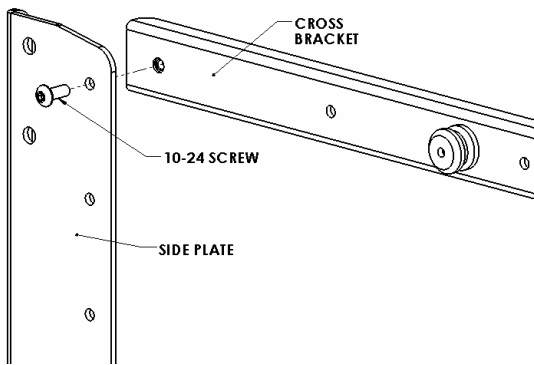

Figure 4

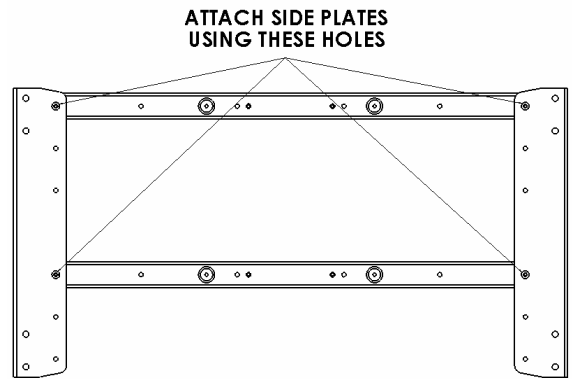

Figure 5

3. **Bracket Installation:** Place nylon spacers over mounting holes of screen and attach brackets to back of display using the M6 screws (see Figure 6 & Figure 7). Do not over tighten screws.

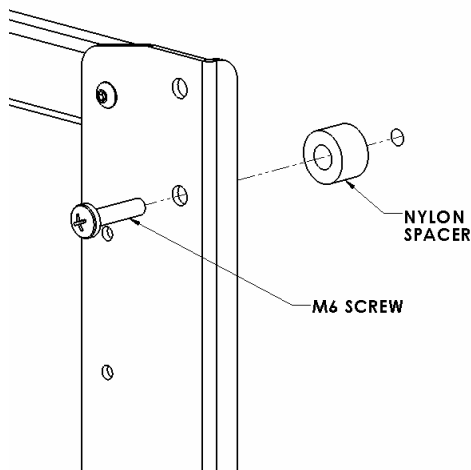

Figure 6

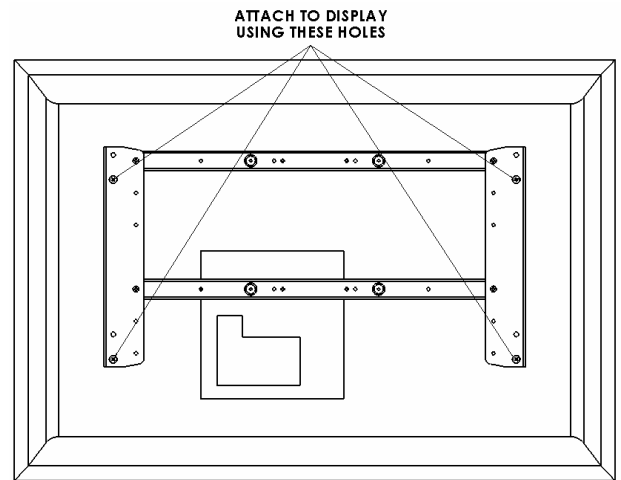

Figure 7

4. Follow the Chief mount instruction manual for screen installation.

J-Series VESA Interface Installation:

5. **Side Bracket Assembly:** Attach center brackets to side brackets using the 10-24 button head cap screws (see Figure 8 & Figure 9).

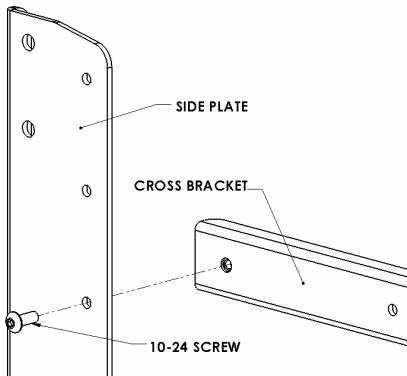

Figure 8

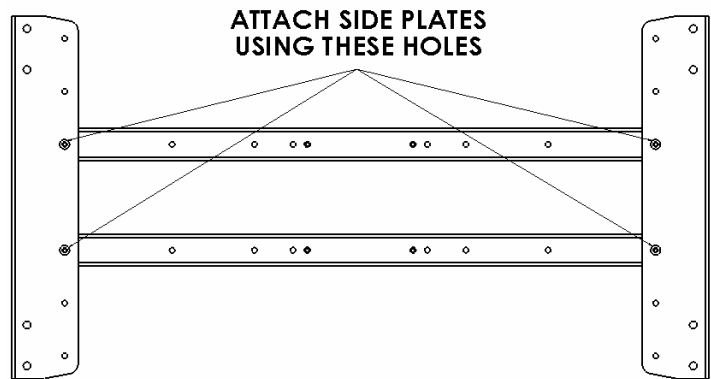

Figure 9

6. **Bracket Installation:** Place nylon spacers over mounting holes of screen and attach brackets to back of display using the M6 screws (see Figure 10 & Figure 11). Do not over tighten screws.

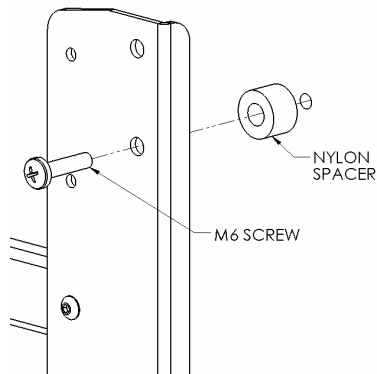

Figure 10

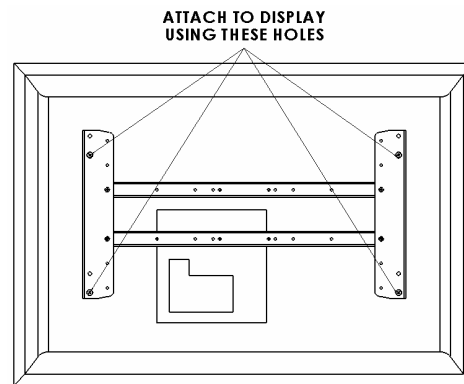

Figure 11

7. **Installation onto J-series:** Attach to J-series mount using M4 screws (supplied with J-series) in threaded holes (see Figure 12 & Figure 13)

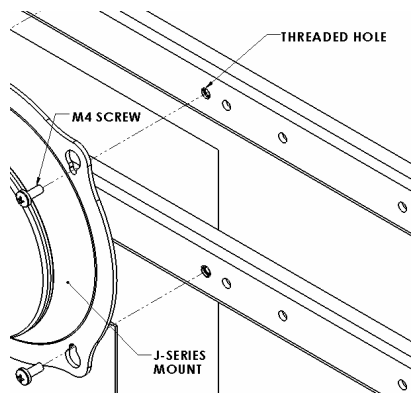

Figure 12

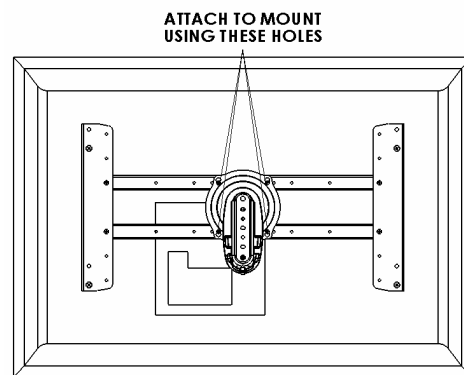

Figure 13