

# INSTALLATION INSTRUCTIONS

## MSB-6156 DISPLAY MOUNTING BRACKET

Prior to assembly, unpack carton completely and verify contents.

If you are missing any of the following components, please contact Customer Service at 1-800/582-6480

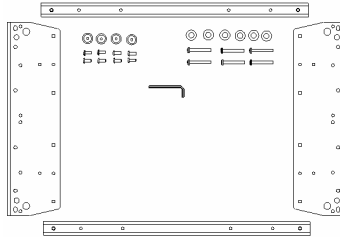

Figure 1

- (2) Interface Side Brackets
- (4) Mounting Buttons – Tapped
- (6) M5 x 40mm Phillips Head Cap Screws
- (1) 1/8" Allen Key

- (2) Interface Center Brackets
- (8) 10-24 x .5 Button Head Cap Screws
- (6) .74 x .39 x 1.0 Nylon Spacers

BEFORE PROCEEDING, READ INSTALLATION INSTRUCTIONS COMPLETELY

**CAUTION!** DISPLAYS ARE EXTREMELY FRAGILE.

**WARNING!** ALL COMPONENTS MUST BE SECURELY FASTENED TO A STRUCTURAL MEMBER CAPABLE OF SUPPORTING 4 TIMES THE COMBINED WEIGHT OF ALL COMPONENTS PLUS THE EQUIPMENT BEING MOUNTED. IF IT CANNOT SUPPORT THIS WEIGHT, THE STRUCTURE MUST BE REINFORCED. THE MAXIMUM WEIGHT TO BE INSTALLED ON THE INTERFACE IS 125 POUNDS (79.38 KG).

**NOTE:** If installing screen on a Chief J-series wall mount, proceed to Step 3 (J-Series VESA Interface Installation).

1. **Chief Q-latch Button Installation (Used with MSR, MTR, MWH, MWR, MCS and MCD mounts):**  
Using a 10-24 button head cap screw inserted from back side of bracket, secure mounting button, with chamfered hole of mounting button (larger surface) facing bracket, to center brackets (four places) (see Figure 2 & Figure3).
2. Proceed to Step 4 (Side Bracket Assembly).

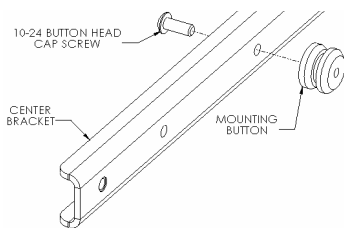

Figure 2

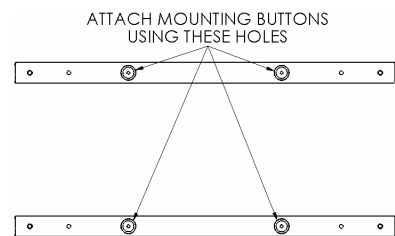

Figure 3

3. **J-Series VESA Interface Installation:** Using the 10-24 button head cap screws along with the 10-24 Nylock nuts (provided with J-Series mount), attach VESA interface from J-Series mount to center brackets (see Figure 4 & Figure 5).

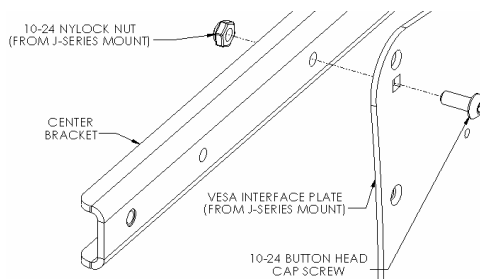

Figure 4

ATTACH VESA INTERFACE TO CENTER BRACKETS USING THESE HOLES

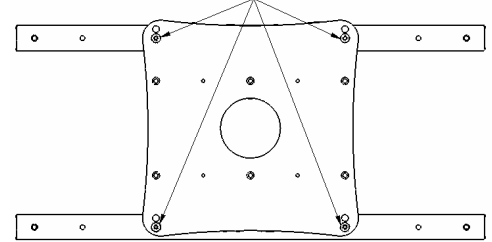

Figure 5

4. **Side Bracket Assembly:** Attach center brackets to side brackets using the 10-24 button head cap screws (see Figure 6 & Figure 7).

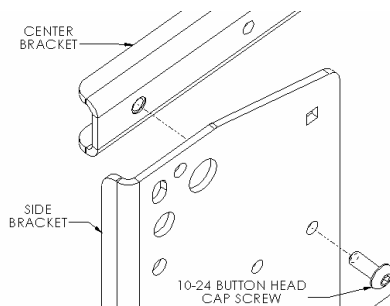

Figure 6

ATTACH CENTER AND SIDE BRACKETS USING THESE HOLES

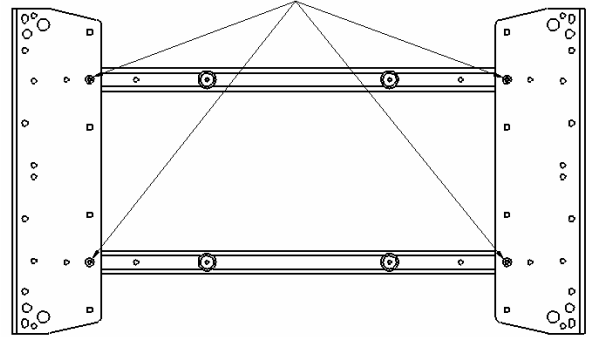

Figure 7

5. **Bracket Installation:** Stack nylon spacers over mounting holes of screen and attach brackets to back of display using the M5 screws (see Figure 8 & Figure 9). Do not over tighten screws.
6. Follow the Chief mount instruction manual for screen installation.

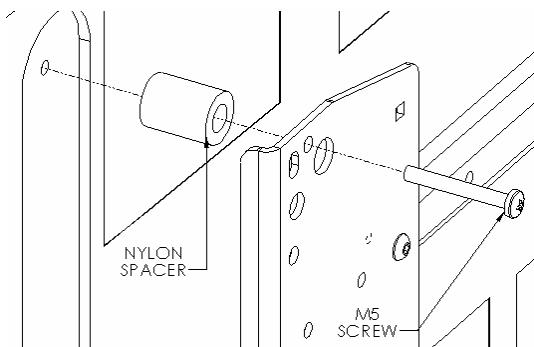

Figure 8

ATTACH BRACKET TO BACK OF DISPLAY USING THESE HOLES

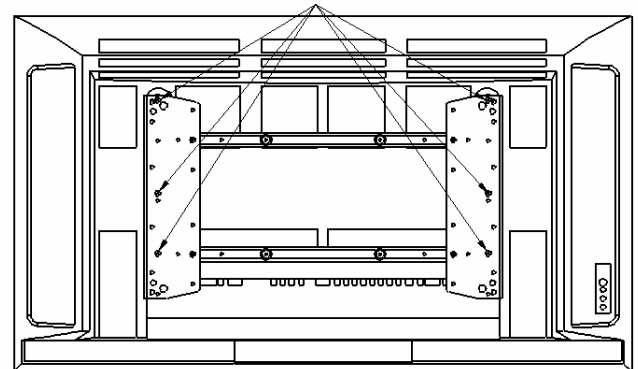

Figure 9