INSTALLATION INSTRUCTIONS

MSB-6442

FLAT PANEL DISPLAY MOUNTING BRACKET

Prior to assembly, unpack carton completely and verify contents.

If you are missing any of the following components, please contact Customer Service at 1-800/582-6480

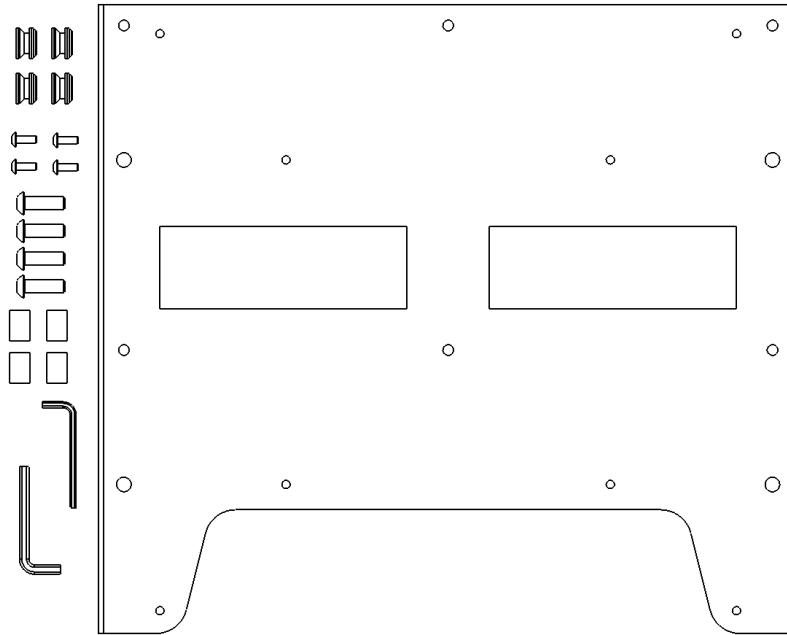

Figure 1

- | | |
|--|-----------------------------------|
| (1) Interface Bracket | (4) Mounting Button – Tapped |
| (4) 10-24 x .5 Button Head Cap Screw | (4) M8 x 25 Button Head Cap Screw |
| (4) .75 OD x .34 ID x.500 L Nylon Spacer | (1) 1/8 Allen Key |
| (1) 5mm Allen Key | |

BEFORE PROCEEDING, READ INSTALLATION INSTRUCTIONS COMPLETELY

CAUTION! **DISPLAYS ARE EXTREMELY FRAGILE.**

WARNING! **ALL COMPONENTS MUST BE SECURELY FASTENED TO A STRUCTURAL MEMBER CAPABLE OF SUPPORTING 4 TIMES THE COMBINED WEIGHT OF ALL COMPONENTS PLUS THE EQUIPMENT BEING MOUNTED. IF IT CANNOT SUPPORT THIS WEIGHT, THE STRUCTURE MUST BE REINFORCED.**

THE MAXIMUM WEIGHT TO BE INSTALLED ON THE MOUNT IS 125 POUNDS (56.74 KG).



Chief Manufacturing, a division of Milestone AV Technologies
8401 Eagle Creek Parkway, Savage, MN 55378
P: 800.582.6480 / 952.894.6280 F: 877.894.6918 / 952.894.6918

8840-000098 Rev01
©2008 Milestone AV Technologies
04/08

- Using a 10-24 button head cap screw inserted from back side of bracket, secure mounting button, with chamfered hole of mounting button (larger surface) facing bracket, to top and bottom brackets (four places) (see Figure 2 & Figure 3).

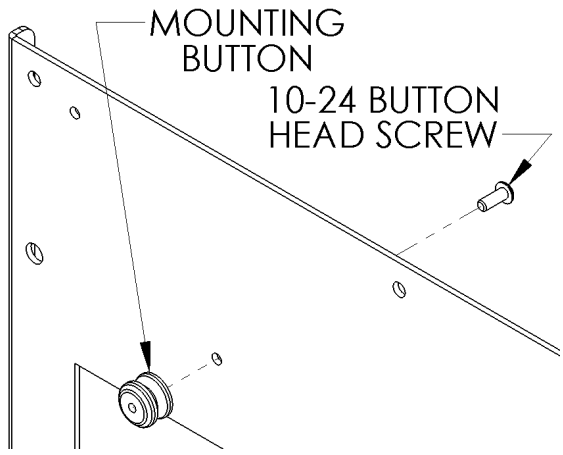

Figure 2

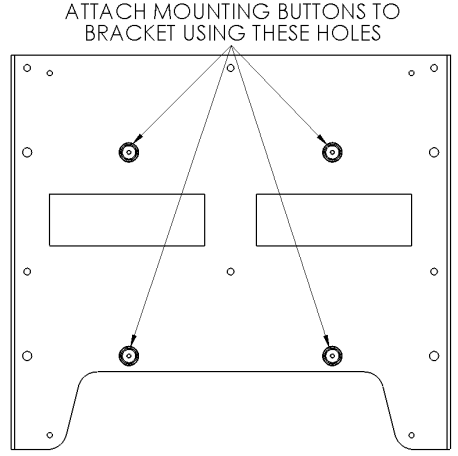

Figure 3

- Place Nylon spacers over mounting holes on back of screen. Attach mounting brackets to display using the M8 screws (see Figure 4 & Figure 5)
- With the aid of another person, lift your display up to the Chief Mount, aligning buttons of mounting brackets with slots in the Chief Mount. Lower safety latch on the Chief Mount to secure your display, making sure latch is completely engaged.

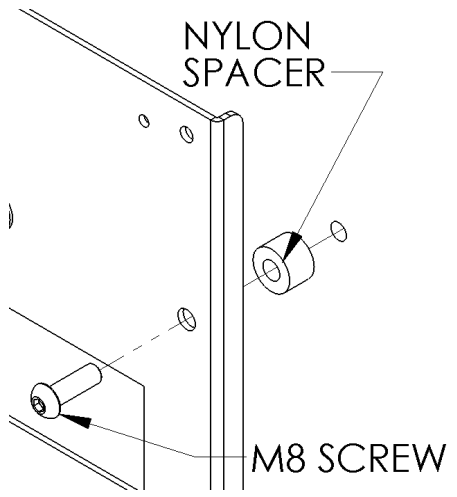

Figure 4

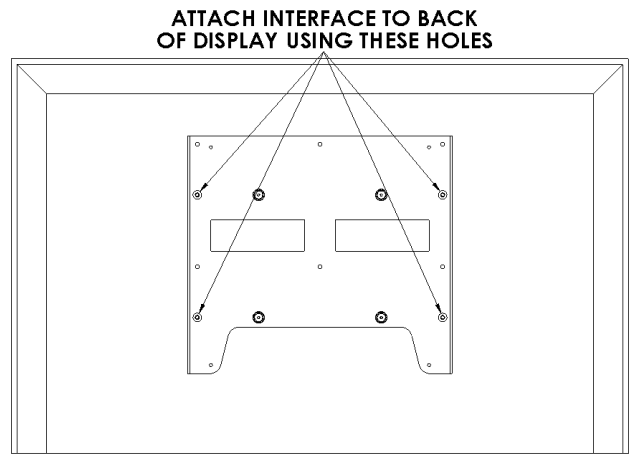

Figure 5