

INSTALLATION INSTRUCTIONS

MSB-6534 DISPLAY MOUNTING BRACKET

Prior to assembly, unpack carton completely and verify contents.

If you are missing any of the following components, please contact Customer Service at 1-800/582-6480

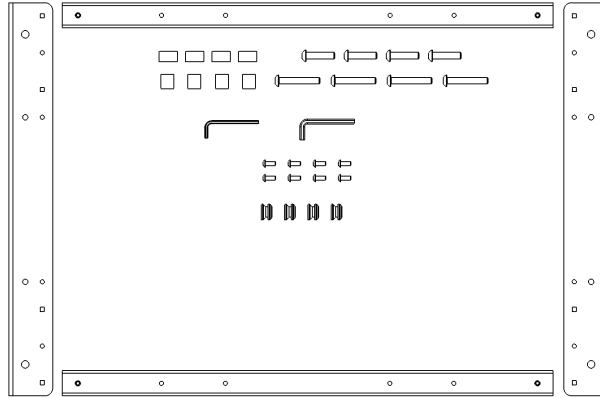

Figure 1

- (2) Interface Side Brackets
- (4) Mounting Buttons – Tapped
- (4) M8 x 35mm Button Head Cap Screw
- (4) .680 x .390 x .625 Nylon Spacer
- (1) 1/8" Allen Key

- (2) Interface Center Brackets
- (8) 10-24 x .500 Button Head Cap Screws
- (4) M8 x 50mm Button Head Cap Screw
- (4) .520 x .320 x .875 Nylon Spacers
- (4) 5mm Hex Key

BEFORE PROCEEDING, READ INSTALLATION INSTRUCTIONS COMPLETELY

CAUTION! **DISPLAYS ARE EXTREMELY FRAGILE.**

WARNING! **ALL COMPONENTS MUST BE SECURELY FASTENED TO A STRUCTURAL MEMBER CAPABLE OF SUPPORTING 4 TIMES THE COMBINED WEIGHT OF ALL COMPONENTS PLUS THE EQUIPMENT BEING MOUNTED. IF IT CANNOT SUPPORT THIS WEIGHT, THE STRUCTURE MUST BE REINFORCED. THE MAXIMUM WEIGHT TO BE INSTALLED ON THE INTERFACE IS 125 POUNDS (79.38 KG).**

NOTE: If installing screen on a Chief J-series wall mount, proceed to Step 3 (J-Series VESA Interface Installation).

1. **Chief Q-latch Button Installation (Used with M-series mounts):** Using a 10-24 button head cap screw inserted from back side of bracket, secure mounting button, with chamfered hole of mounting button (larger surface) facing bracket, to center brackets (four places) (see Figure 2 & Figure3).
2. Proceed to Step 4 (Side Bracket Assembly).

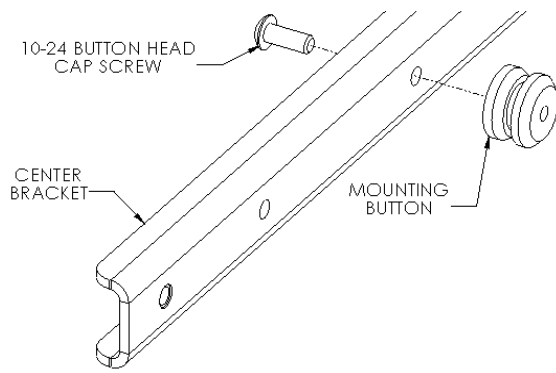

Figure 2

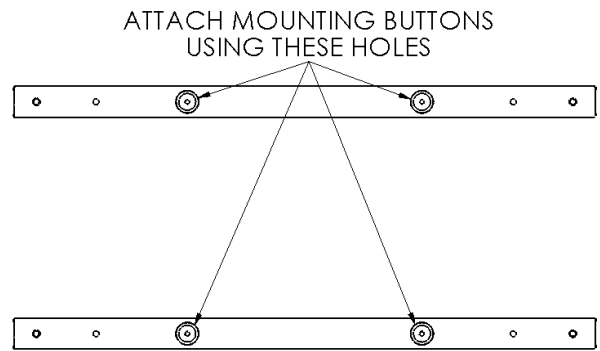

Figure 3

3. **J-Series VESA Interface Installation:** Using the 10-24 button head cap screws along with the 10-24 Nylock nuts (provided with J-Series mount), attach VESA interface from J-Series mount to center brackets (see Figure 4 & Figure 5).

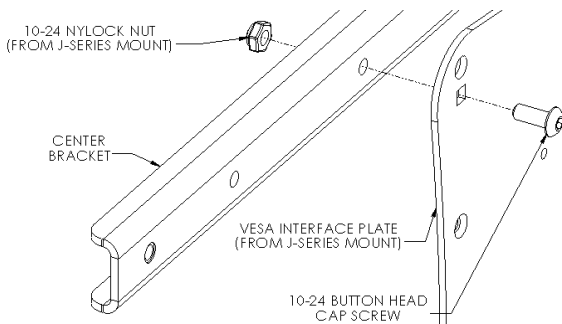

Figure 4

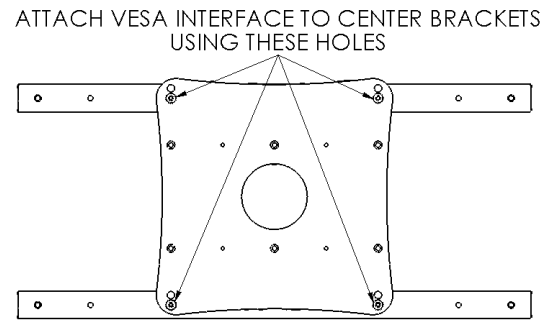

Figure 5

4. **Side Bracket Assembly:** Attach center brackets to side brackets using the 10-24 button head cap screws (see Figure 6 & Figure 7).

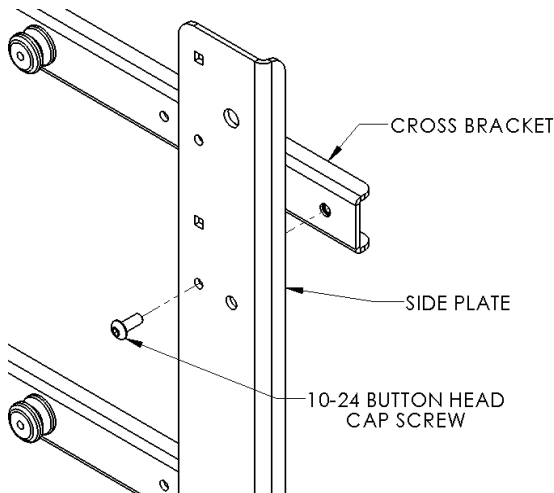

Figure 6

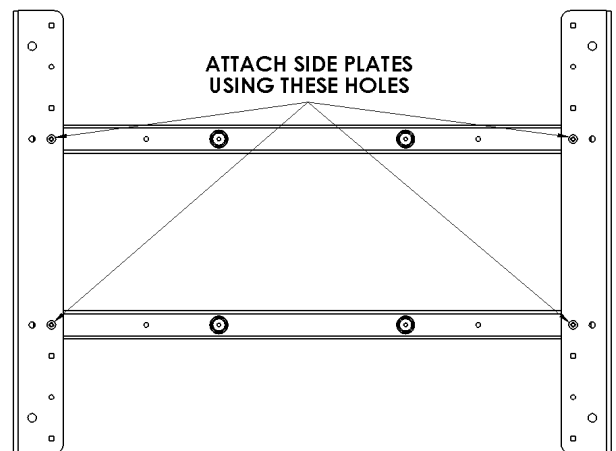

Figure 7

5. **Bracket Installation:** Place .875" long Nylon Spacers over mounting holes of screen and attach brackets to back of display using the M8 x 35mm screws (see Figure 8 & Figure 9). If more spacing is required stack both sets of spacer and use the M8 x 50mm screws. Do not over tighten screws.

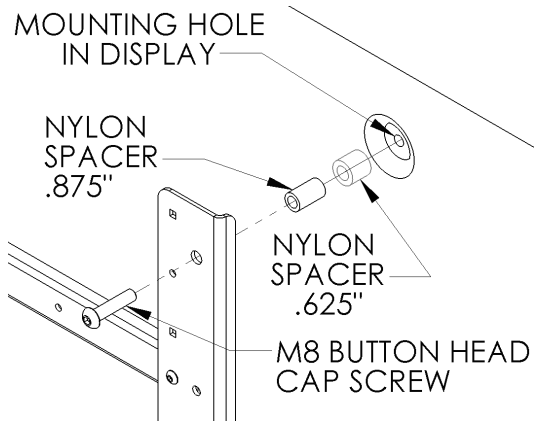

Figure 8

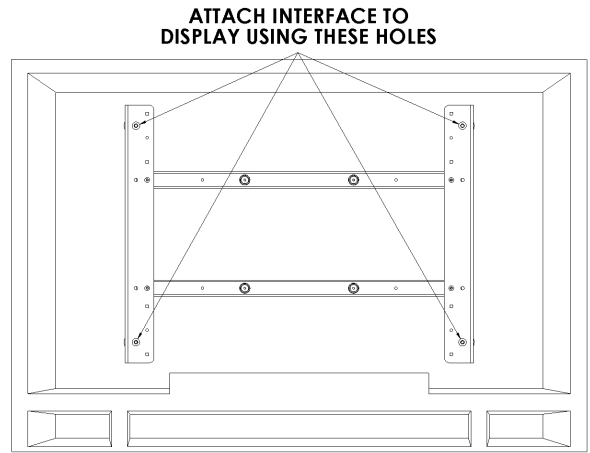

Figure 9

6. Follow the Chief mount instruction manual for screen installation.