

INSTALLATION INSTRUCTIONS

MODEL: MSP-CD93C Custom Projector Bracket

The Christie MSP-CD93C custom video projector ceiling mount is designed to provide fast, simple and secure installation. Special roll, pitch, yaw and horizontal adjustments simplify projection positioning for image alignment. The mount also has positive registration lock so the projector may be removed without losing projector mount registration.

PARTS

(1) BRACKET, Custom HB	(4) NUT, Flange, Hex, 5/16-18
(7) SCREW, Button Head Cap, M8 x 16mm	(7) FLAT WASHER, Standard Machine Screw 8mm
(1) HEX KEY, 5mm	

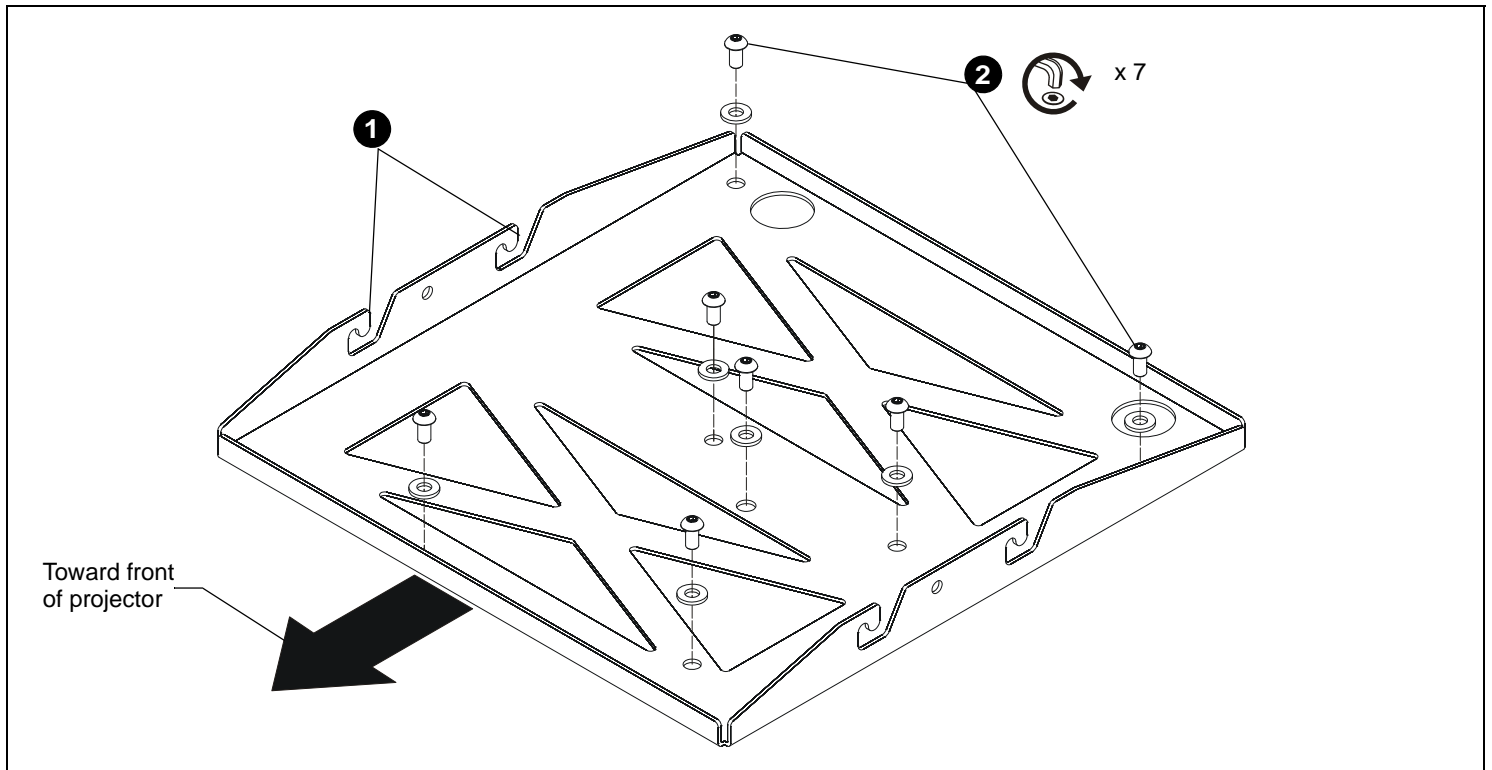

Figure 1:

INSTALLATION



WARNING: IMPROPER INSTALLATION MAY RESULT IN SERIOUS PERSONAL INJURY! All components must be securely fastened to each other and to the ceiling, and the ceiling must be capable of supporting five times the total weight of the installation.



CAUTION: This MSP bracket mount is designed to support the weight of only one projector per mount. DO NOT attempt to attach more than one projector to the same mount!

1. Place HB bracket on underside of the projector and line up the seven screw holes on the bracket with the seven corresponding holes on the projector. Ensure that the side hooks open towards back of the projector. (See Figure 1)
2. Attach HB bracket to projector using seven M8 x 16mm button head screws through washers. Install each screw partially to make sure all screws are aligned correctly before tightening the screws to the bracket. (See Figure 1)

Continued...

INSTALLATION INSTRUCTIONS

Continued...

CAUTION: Installing a ceiling mount requires the presence of two persons familiar with mechanical installations. A third assistant is recommended.

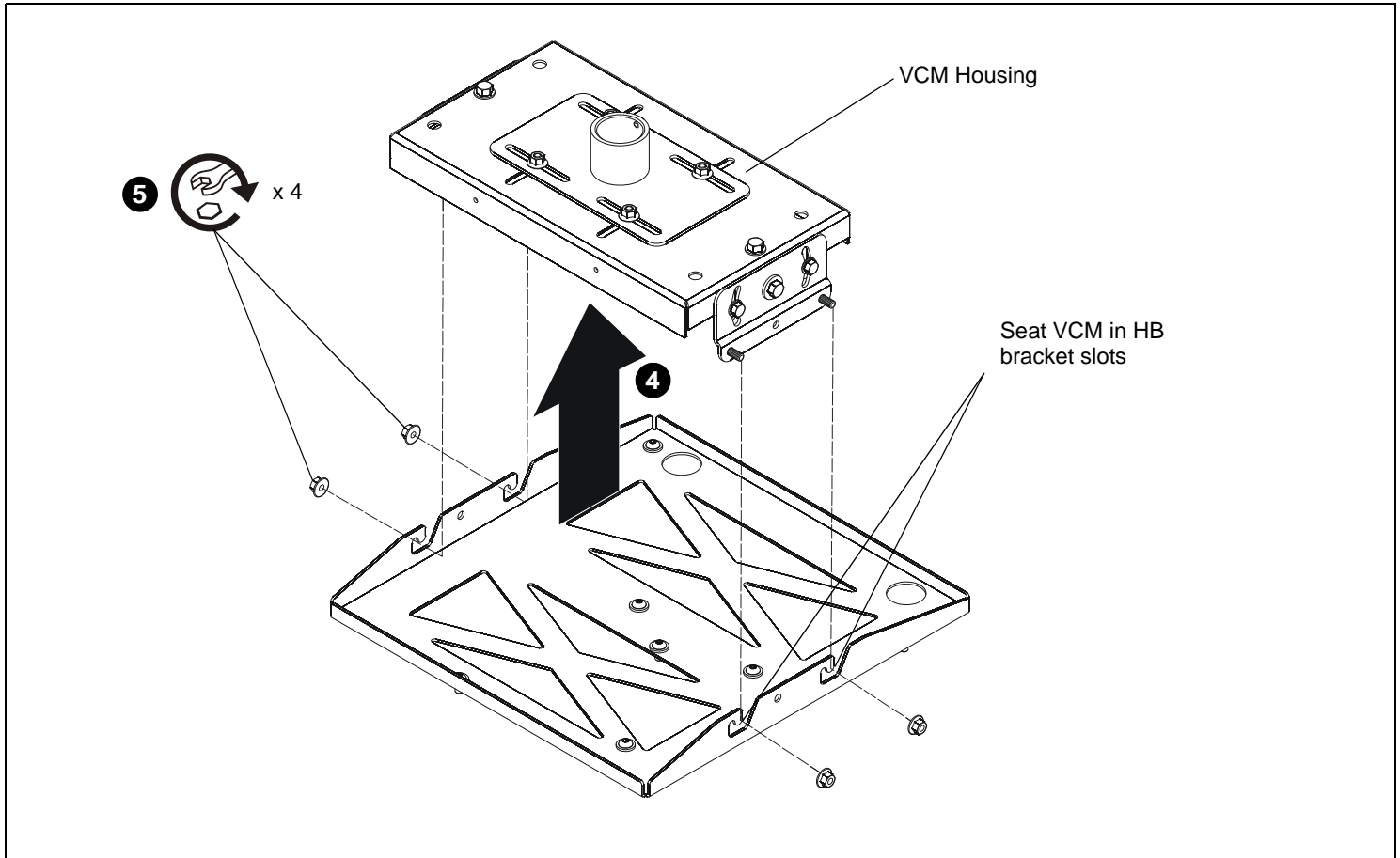

Figure 2:

3. Attach VCM housing to your method of support and tighten firmly so the VCM housing is square to the screen.
4. With help of assistants, lift the projector and install it to the four studs extending from the VCM housing. Ensure that the VCM housing is seated in slots on HB bracket. (See Figure 2)
5. Tighten the four 5/16" flange nuts. (See Figure 2)

CHRISTIE®