

INSTALLATION INSTRUCTIONS

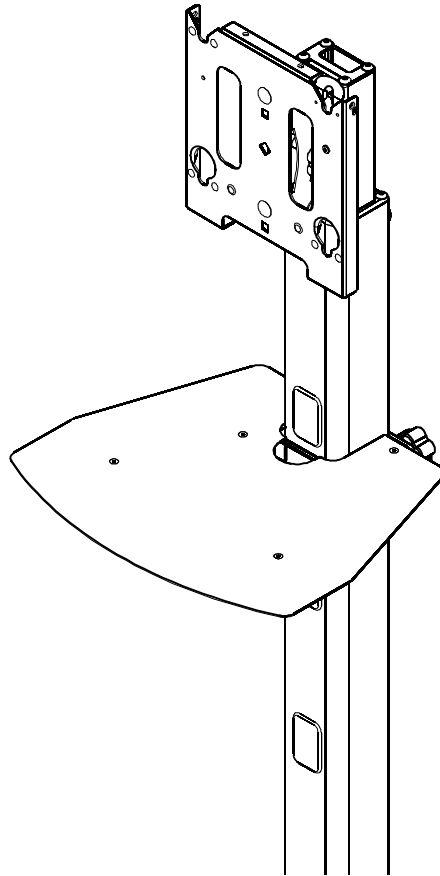

Shelf Accessory

SONY®

CH-SHELF

DISCLAIMER

Sony Electronics, Inc., and its affiliated corporations and subsidiaries (collectively, "Sony"), intend to make this manual accurate and complete. However, Sony makes no claim that the information contained herein covers all details, conditions or variations, nor does it provide for every possible contingency in connection with the installation or use of this product. The information contained in this document is subject to change without notice or obligation of any kind. Sony makes no representation of warranty, expressed or implied, regarding the information contained herein. Sony assumes no responsibility for accuracy, completeness or sufficiency of the information contained in this document.

! IMPORTANT WARNINGS AND CAUTIONS!

! WARNING: A WARNING alerts you to the possibility of serious injury or death if you do not follow the instructions.

! CAUTION: A CAUTION alerts you to the possibility of damage or destruction of equipment if you do not follow the corresponding instructions.

! WARNING: Failure to read, thoroughly understand, and follow all instructions can result in serious personal injury, damage to equipment, or voiding of factory warranty! It is the installer's responsibility to make sure all components are properly assembled and installed using the instructions provided.

! WARNING: Failure to provide adequate structural strength for this component can result in serious personal injury or damage to equipment! It is the installer's responsibility to make sure the structure to which this component is attached can support five times the combined weight of all equipment. Reinforce the structure as required before installing the component.

! WARNING: Exceeding the weight capacity can result in serious personal injury or damage to equipment! It is the installer's responsibility to make sure the combined weight of all components attached to this accessory does not exceed 25 lbs (11.34 kg).

LEGEND

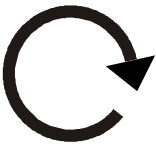
	Tighten Fastener
	Apretar elemento de fijación
	Befestigungsteil festziehen
	Apertar fixador
	Serrare il fissaggio
	Bevestiging vastdraaien
Serrez les fixations	

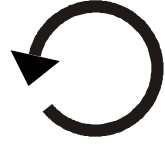
	Loosen Fastener
	Aflojar elemento de fijación
	Befestigungsteil lösen
	Desapertar fixador
	Allentare il fissaggio
	Bevestiging losdraaien
Desserrez les fixations	

PARTS

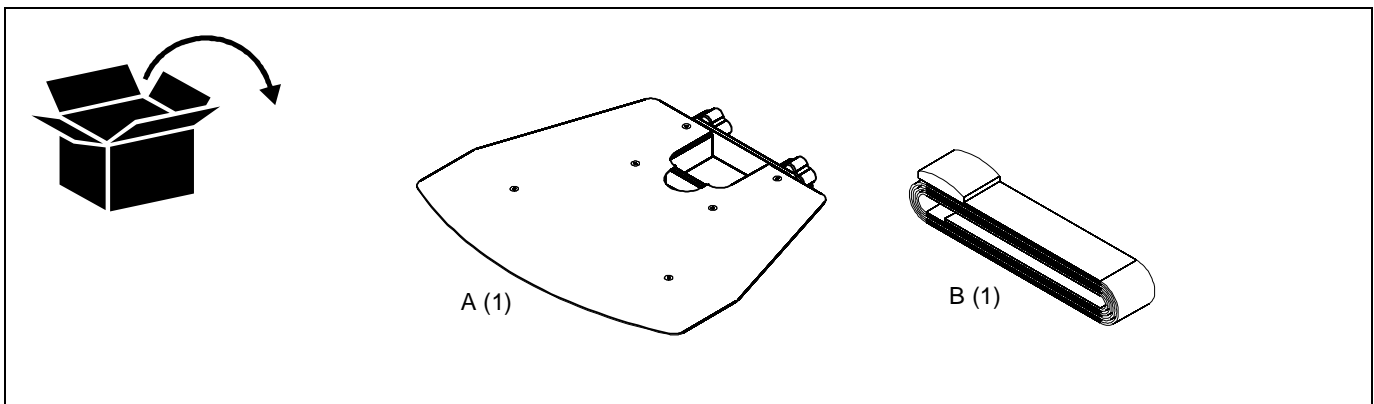

INSTALLATION



WARNING: IMPROPER INSTALLATION CAN LEAD TO EQUIPMENT FALLING CAUSING SERIOUS PERSONAL INJURY OR DAMAGE TO EQUIPMENT! DO NOT substitute hardware! Use only hardware provided by manufacturer.



WARNING: EXCEEDING MAXIMUM WEIGHT CAPACITY MAY LEAD TO SERIOUS PERSONAL INJURY OR DAMAGE TO EQUIPMENT! It is the user's responsibility to ensure the total amount of weight placed on the shelf does not exceed 25 lbs (11.34 kg).

Shelf Installation

The CH-SHELF is designed to be mounted onto the CH-SMF1. The shelf can only be installed BELOW the adjustment knob on the center post. (See Figure 1)

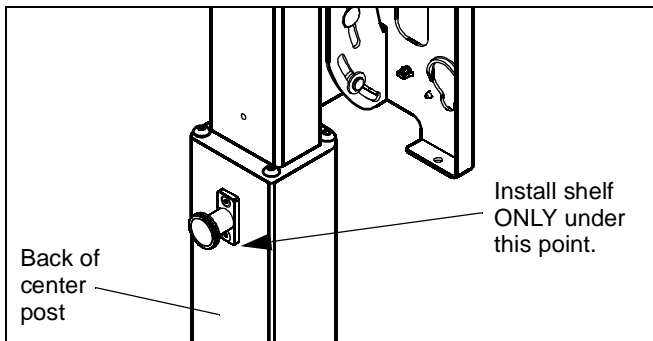

Figure 1

To install the CH-SHELF:

1. Loosen back bracket on shelf (A) by turning both knobs counterclockwise to loosen them. **Do NOT remove knobs.** (See Figure 2)

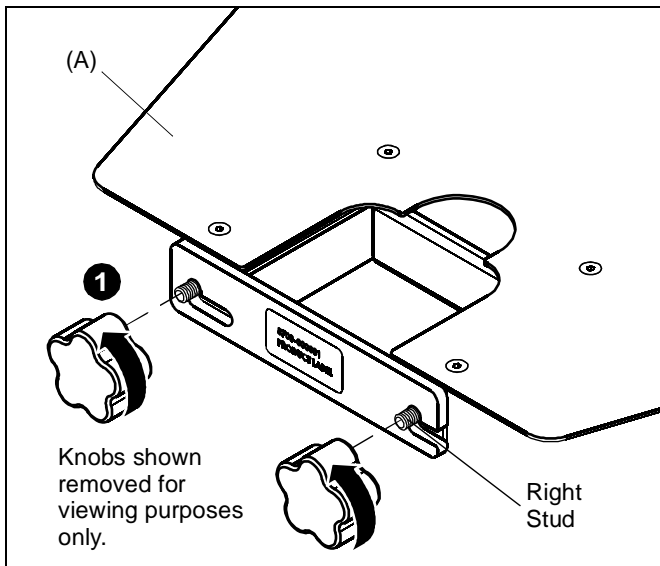

Figure 2

2. Slide bracket to the left until it disengages from the shelf's right stud. (See Figure 3)

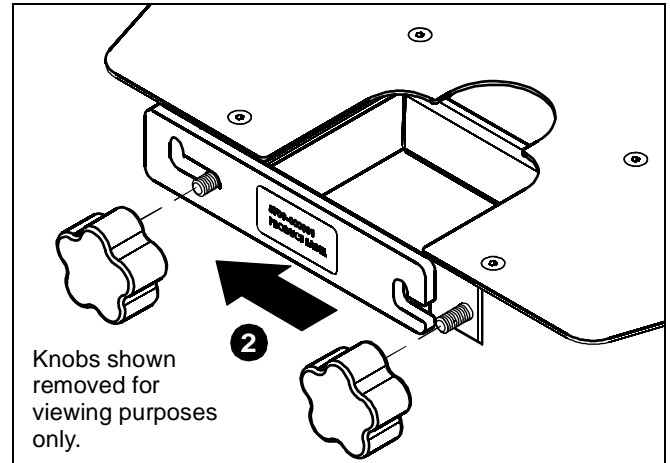

Figure 3

3. Let the bracket drop down and hang from the shelf's left stud. (See Figure 4)

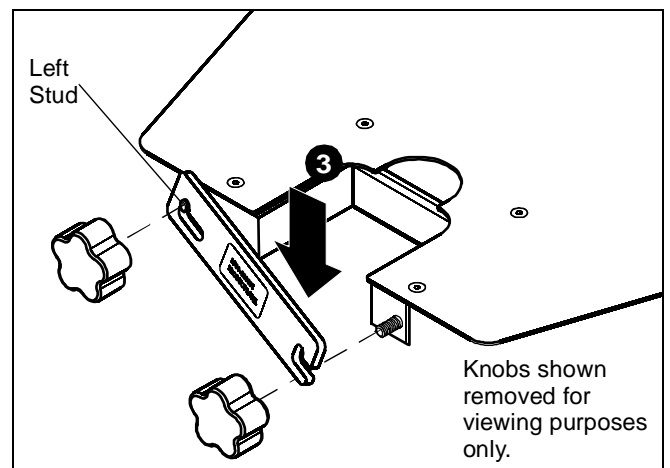

Figure 4

4. Shelf should be located directly above or directly below a cable management opening in the post. (See Figure 5)
5. Place shelf around center post and level. (See Figure 6)

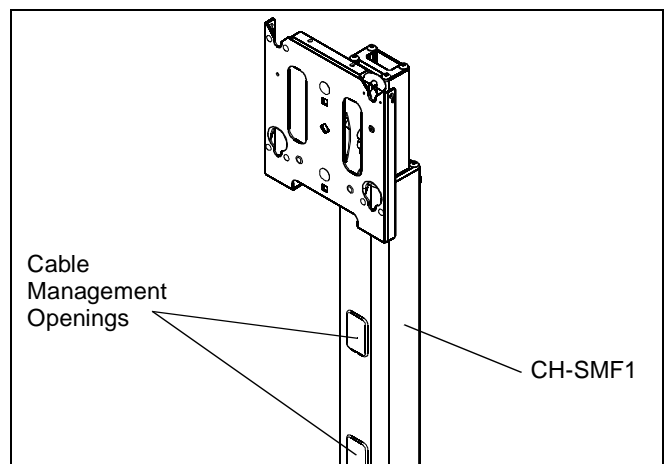

Figure 5

6. Raise shelf bracket and hook over shelf's right stud. (See Figure 6)

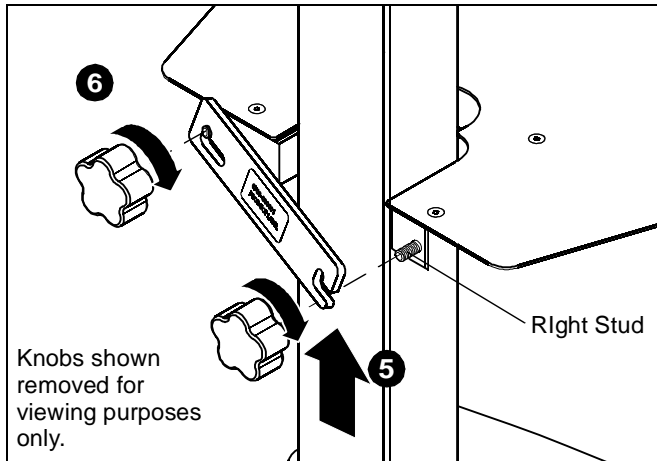

Figure 6

7. Turn both knobs clockwise to tighten the shelf in place. (See Figure 6)



CAUTION: This shelf is intended for use with equipment weighing not more than 25 lbs (11.34 kg) and having dimensions that will permit it to sit evenly on this shelf. Use with other equipment may result in instability causing possible injury.



CAUTION: Do NOT sit or hang on the shelf. Such use may result in instability causing possible injury and damage to equipment.



CAUTION: Equipment MUST be fastened to the shelf before moving the cart or stand. If equipment is not fastened to the shelf it MUST be removed before moving the cart or stand.

Installing Optional Safety Strap

To install the optional safety strap:

1. Place equipment on shelf (A).
2. Thread strap (B) through slots in shelf (A). (See Figure 7)

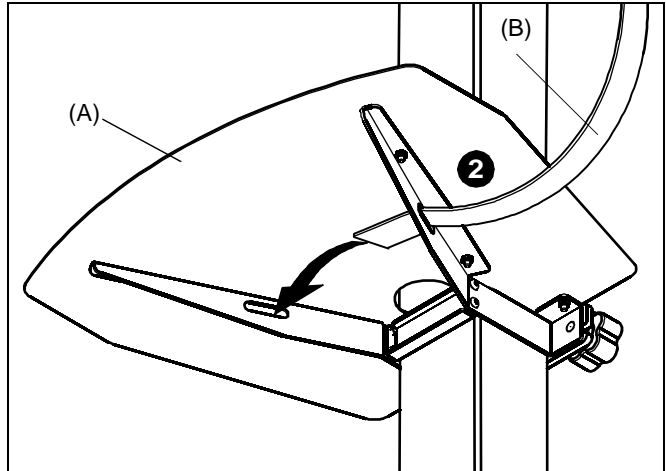

Figure 7

3. Loop strap (B) over top of equipment and slide strap end into clasp. (See Figure 8)

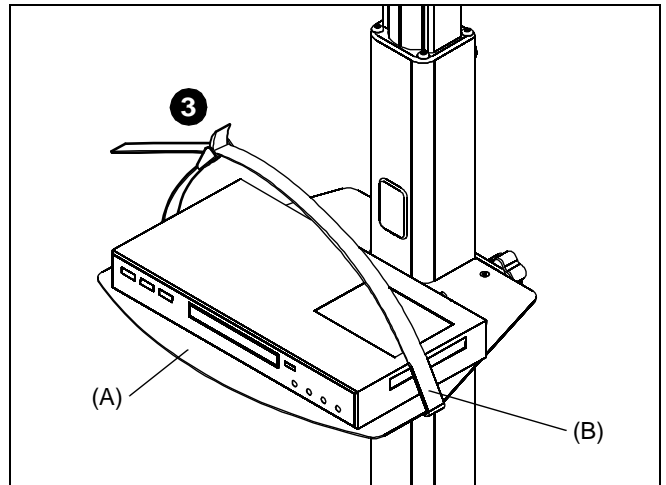

Figure 8

4. Pull strap (B) until tight around equipment and press clasp closed to secure. (See Figure 9)

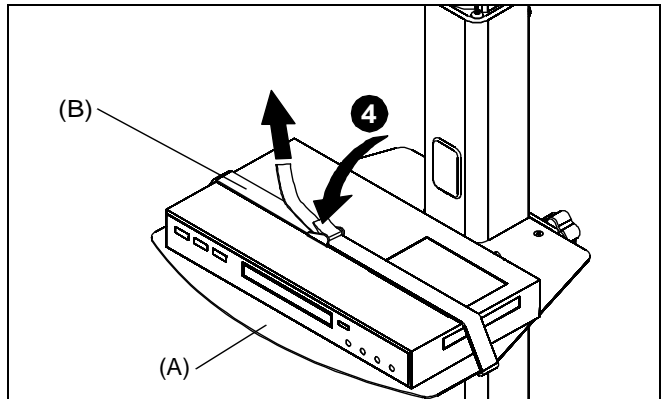

Figure 9

Cable Management

Follow cable management instructions in the stand installation instructions.

SONY[®]

Sony Electronics, Inc.

1 Sony Drive
Park Ridge, NJ 07656
201-930-1000
www.sony.com/displaysystems

8832-000267
08/08