

CH-SMAC400

MID-SIZE FLAT SCREEN ROTATION ACCESSORY

Prior to assembly, unpack carton completely and verify contents.

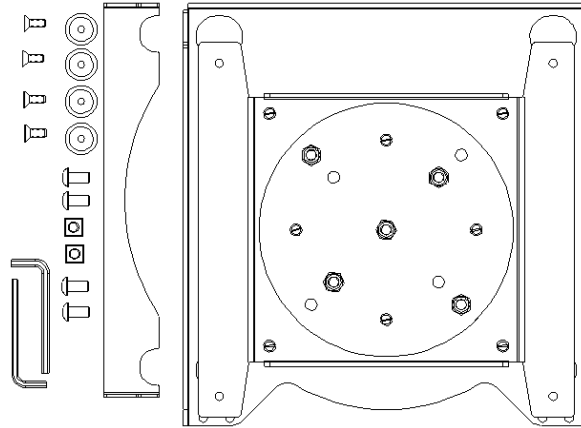

Figure 1

- (1) Rotation Assembly
- (4) 10-24 x .5" Flat Head Cap Screws
- (2) 1/4-20 x .5" Button Head Cap Screws
- (2) 1/4-20 Square Nuts
- (1) 1/8" Hex Key

- (4) Mounting Buttons – Tapped 10-24
- (1) Locking Strap
- (2) 1/4-20 x .5" Security Button Head Cap Screws
- (1) 5/32" Security Hex Key

BEFORE PROCEEDING, READ INSTALLATION INSTRUCTIONS COMPLETELY

CAUTION! FLAT SCREEN DISPLAYS ARE EXTREMELY FRAGILE.

NOTE: The CH-SMAC400 adds 0.94" of depth and 6 lbs (2.72 kg) to overall installation. It is the installer's responsibility to ensure that combined weight of screen and CH-SMAC400 does not exceed the maximum support weight of the mount.

1. Remove screen from mount or, if not installed, install interface bracket to back of screen per instruction supplied with the interface.
2. Attach mounting buttons to Rotation Assembly, using the four 10-24 x 1/2" flat head cap screw. Make sure the buttons are securely fastened. .

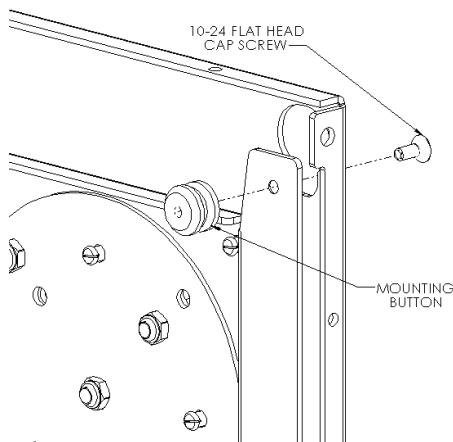

Figure 2

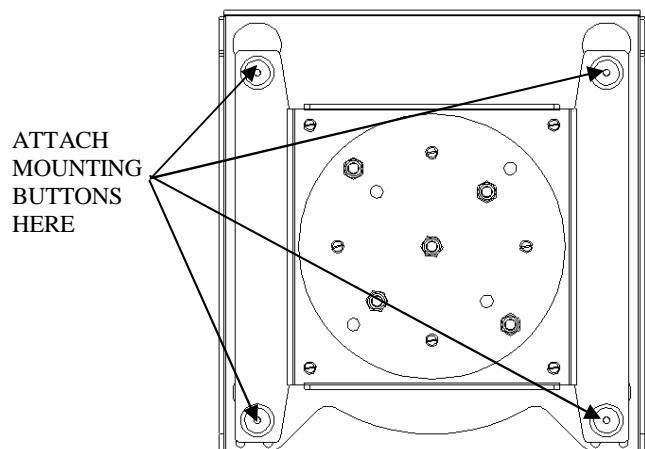

Figure 3

- Attach CH-SMAC400 to Interface Bracket by placing the mounting buttons of interface bracket into the teardrop slots of CH-SMAC400. Make sure the mounting buttons are placed securely in teardrop slots. See Figure 4.

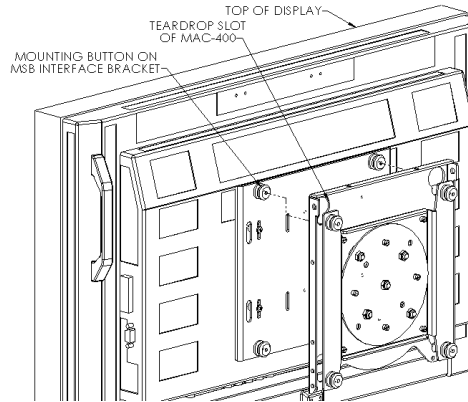

Figure 4

- Place locking strap over top mounting buttons and secure using two 1/4-20 button head cap screws and two 1/4-20 square nuts. Use 1/4-20 tamper-proof security screws and 5/32" security hex key (provided) for added security. See Figure 5 and Figure 6.

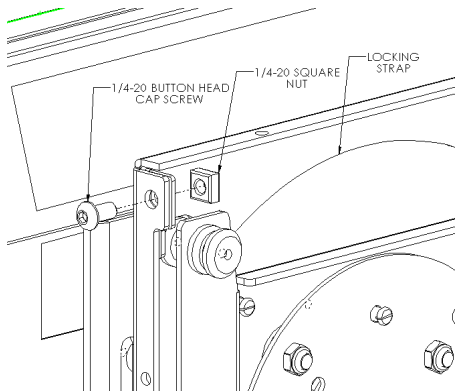

Figure 5

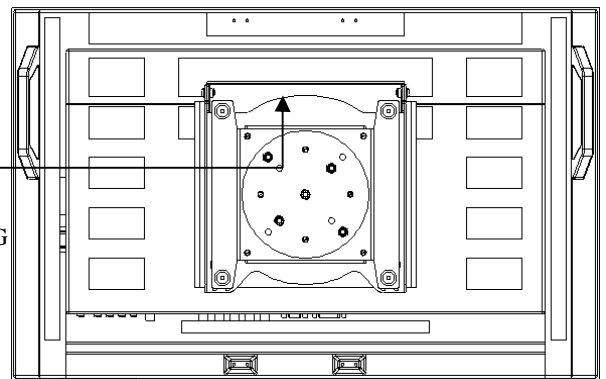

Figure 6

- Set desired amount of friction for rotating the screen by tightening or loosening the four nuts on the back of the CH-SMAC400. See Figure 7.

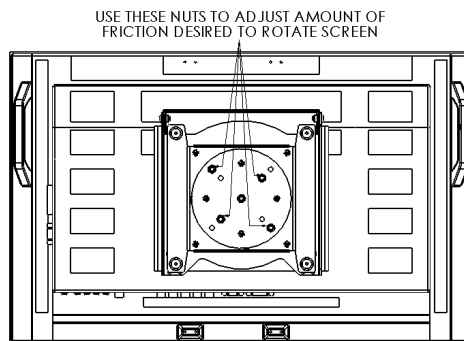

Figure 7

- With the aid of another person, lift flat panel display and CH-SMAC400 up to mount, aligning buttons of rotation accessory with slots in the mount.
- Raise safety latch on mount to secure display, making sure latch is completely engaged.
- If you wish to rotate screen the other way, take screen and rotation accessory from mount, rotate the back plate of the CH-SMAC400 by 90 degrees.
- Install screen on mount.
- Use holes on outside bends to tie wires for cable management.
- On some mounts, you may have to increase friction on tilting and/or roll mechanisms since the CH-SMAC400 adds depth to overall installation.