

---

# INSTALLATION INSTRUCTIONS

---

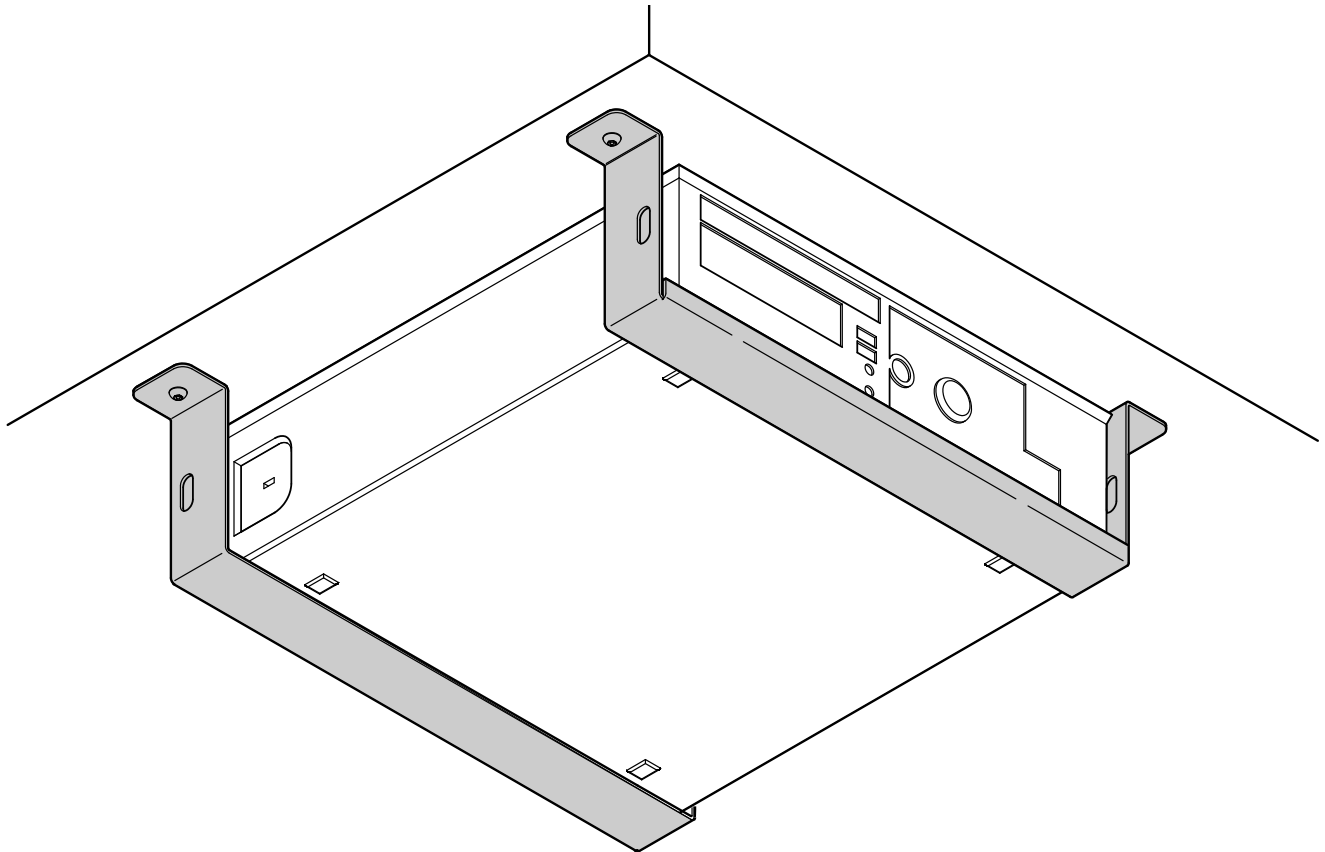

---

**Desk Mount Bracket**

---

**DISCLAIMER**

CSAV, Inc., and its affiliated corporations and subsidiaries (collectively, "CSAV"), intend to make this manual accurate and complete. However, CSAV makes no claim that the information contained herein covers all details, conditions or variations, nor does it provide for every possible contingency in connection with the installation or use of this product. The information contained in this document is subject to change without notice or obligation of any kind. CSAV makes no representation of warranty, expressed or implied, regarding the information contained herein. CSAV assumes no responsibility for accuracy, completeness or sufficiency of the information contained in this document.

**! IMPORTANT WARNINGS AND CAUTIONS!**

**! WARNING:** A WARNING alerts you to the possibility of serious injury or death if you do not follow the instructions.

**! CAUTION:** A CAUTION alerts you to the possibility of damage or destruction of equipment if you do not follow the corresponding instructions.

**! WARNING:** Failure to read, thoroughly understand, and follow all instructions can result in serious personal injury, damage to equipment, or voiding of factory warranty! It is the installer's responsibility to make sure all components are properly assembled and installed using the instructions provided.

**! WARNING:** Failure to provide adequate structural strength for this component can result in serious personal injury or damage to equipment! It is the installer's responsibility to make sure the structure to which this component is attached can support five times the combined weight of all equipment. Reinforce the structure as required before installing the component.

**! WARNING:** Exceeding the weight capacity can result in serious personal injury or damage to equipment! It is the installer's responsibility to make sure the combined weight of all components, including CPU, does not exceed 25 lbs (11.3 kg).

**DIMENSIONS**

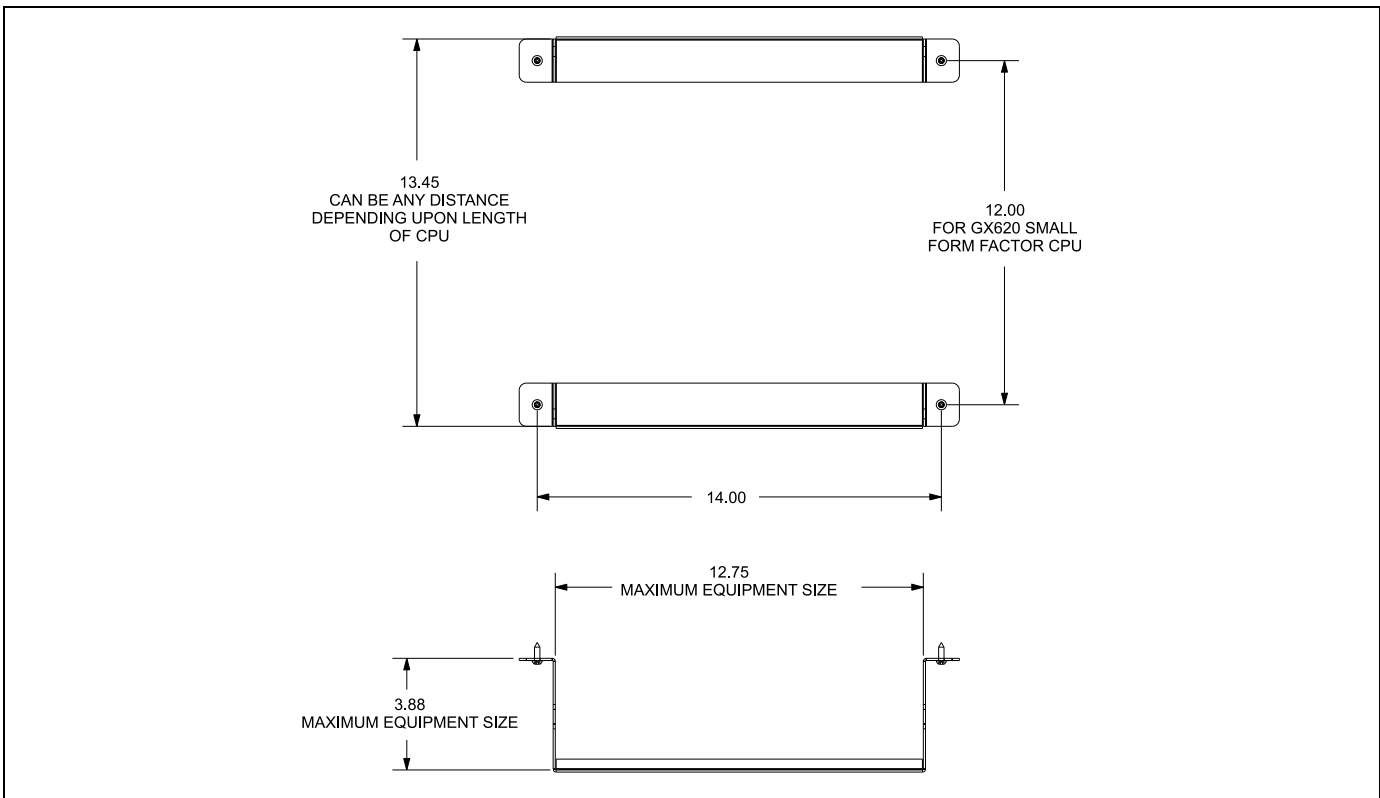

Figure 1

**LEGEND**

	<b>Tighten Fastener</b>
	Apretar elemento de fijación
	Befestigungsteil festziehen
	Apertar fixador
	Serrare il fissaggio
	Bevestiging vastdraaien
Serrez les fixations	

	<b>Pencil Mark</b>
	Marcar con lápiz
	Stiftmarkierung
	Marcar com lápis
	Segno a matita
	Potloodmerkten
Marquage au crayon	

	<b>Loosen Fastener</b>
	Aflojar elemento de fijación
	Befestigungsteil lösen
	Desapertar fixador
	Allentare il fissaggio
	Bevestiging losdraaien
Desserrez les fixations	

	<b>Drill Hole</b>
	Perforar
	Bohrloch
	Fazer furo
	Praticare un foro
	Gat boren
Percez un trou	

	<b>Phillips Screwdriver</b>
	Destornillador Phillips
	Kreuzschlitzschraubendreher
	Chave de fendas Phillips
	Cacciavite a stella
	Kruiskopschroevendraaier
Tournevis à pointe cruciforme	

	<b>Adjust</b>
	Ajustar
	Einstellen
	Ajustar
	Regolare
	Afstellen
Ajuster	

	<b>Open-Ended Wrench</b>
	Llave de boca
	Gabelschlüssel
	Chave de bocas
	Chiave a punte aperte
	Steeksleutel
Clé à fourche	

	<b>Remove</b>
	Quitar
	Entfernen
	Remover
	Rimuovere
	Verwijderen
Retirez	

	<b>By Hand</b>
	A mano
	Von Hand
	Com a mão
	A mano
	Met de hand
À la main	

	<b>Optional</b>
	Opcional
	Optional
	Opcional
	Opzionale
	Optie
En option	

	<b>Hex-Head Wrench</b>
	Llave de cabeza hexagonal
	Sechskantschlüssel
	Chave de cabeça sextavada
	Chiave esagonale
	Zeskantsleutel
Clé à tête hexagonale	

	<b>Security Wrench</b>
	Llave de seguridad
	Sicherheitsschlüssel
	Chave de segurança
	Chiave di sicurezza
	Veiligheidssleutel
Clé de sécurité	

### TOOLS REQUIRED FOR INSTALLATION

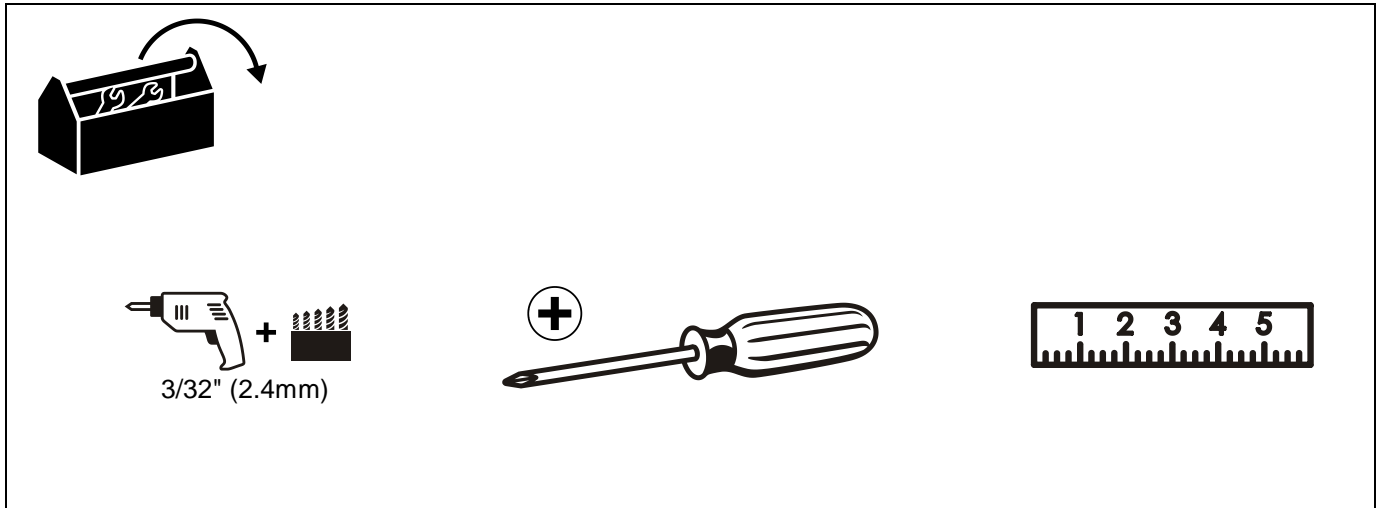

### PARTS

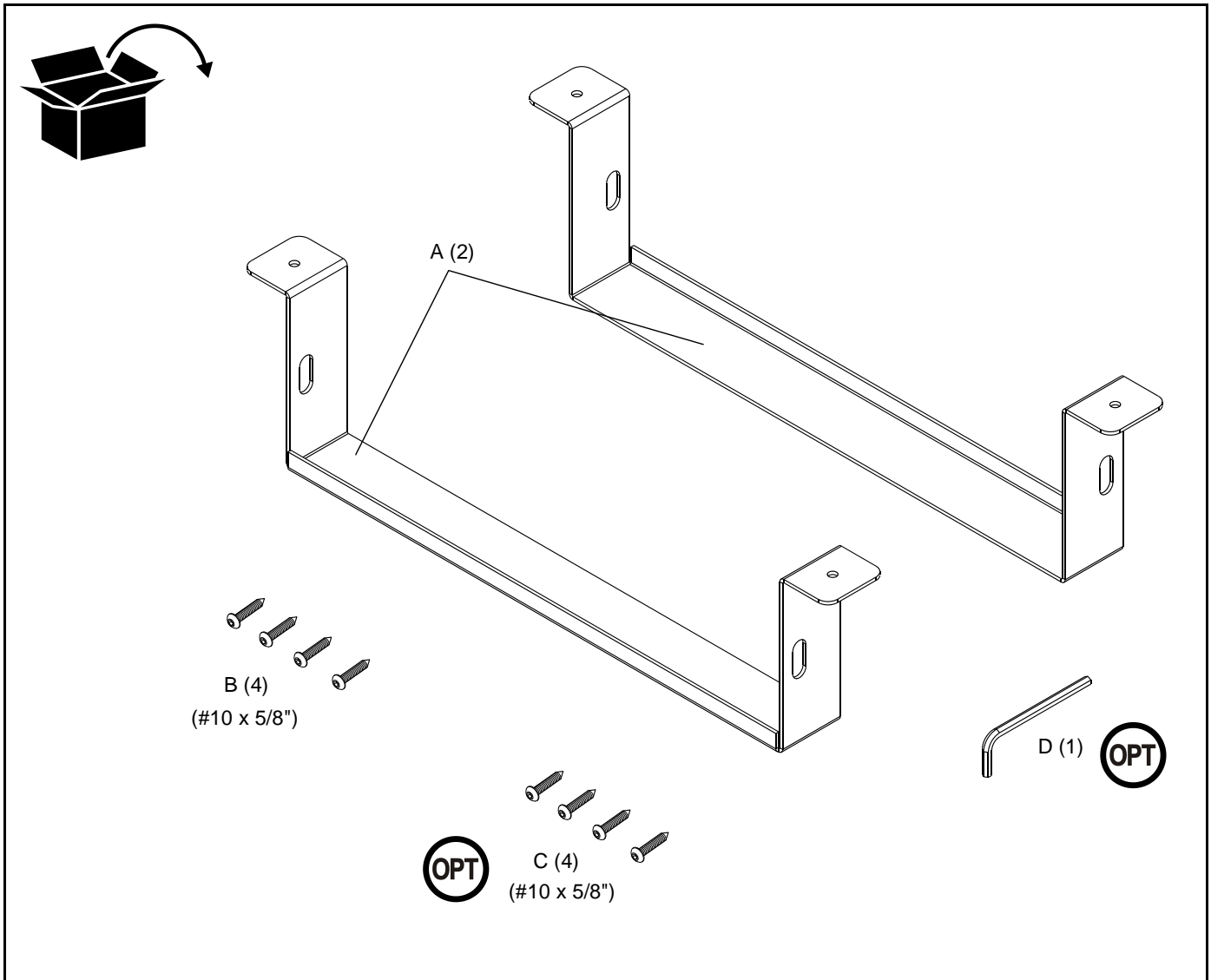

**INSTALLATION**

1. Identify desired mounting location.
2. Mark and drill four 3/32" (2.4mm) pilot holes into mounting surface. (See Figure 1)

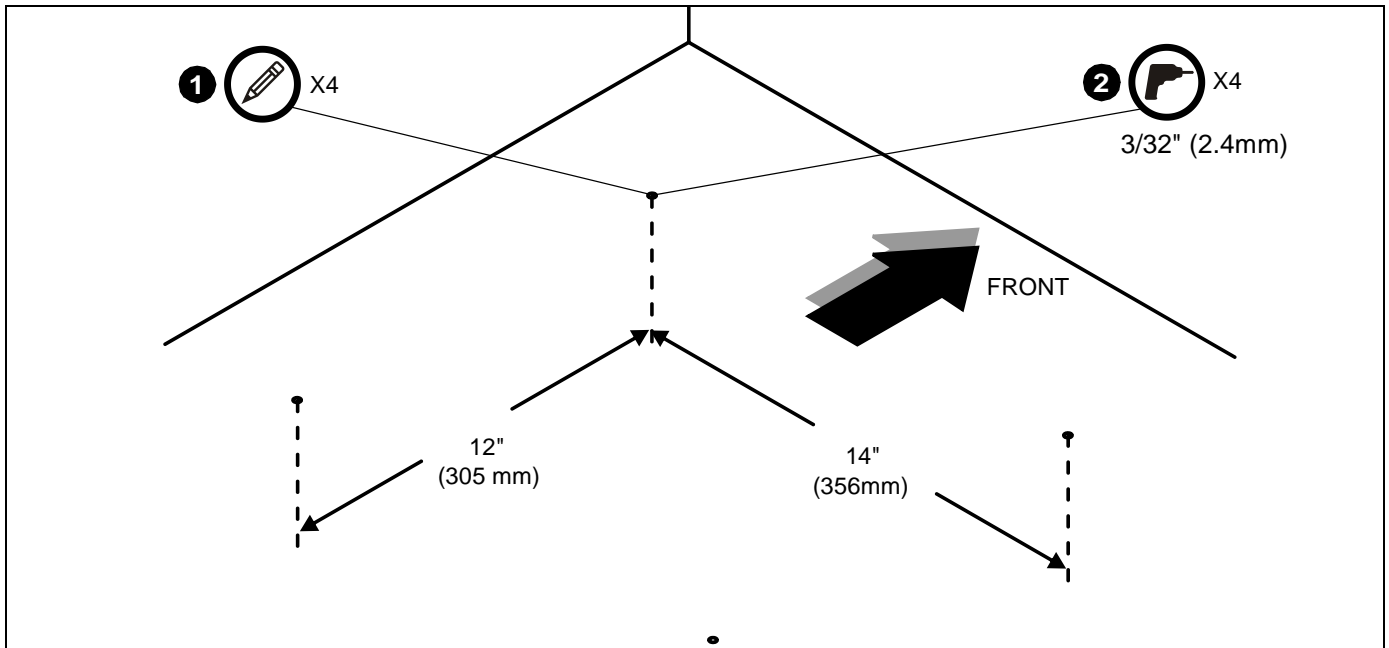

**Figure 2**

3. Orient brackets. (See Figure 3)
4. Attach brackets to mounting surface using four #10 x 5/8" Phillips pan head wood screws.

**NOTE:** Four #10 x 5/8" security screws provided can be used in place of four #10 x 5/8" Phillips pan head wood screws. (See Figure 3)

5. Tighten two Phillips pan head wood screws to secure rear mounting bracket to surface. (See Figure 3)

**IMPORTANT ! :** DO NOT tighten front mounting bracket screws at this time.

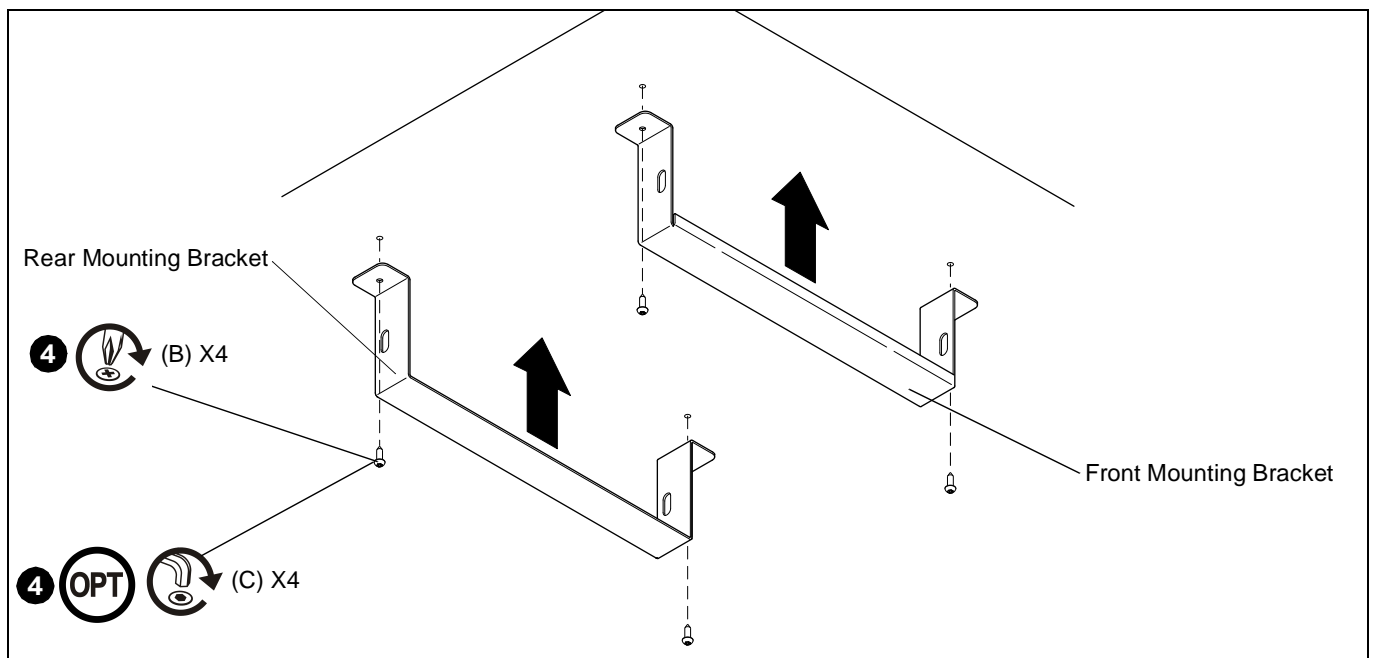

**Figure 3**

- Slide rear of CPU through front bracket and onto rear bracket making sure CPU is properly seated on bracket. (See Figure 4)

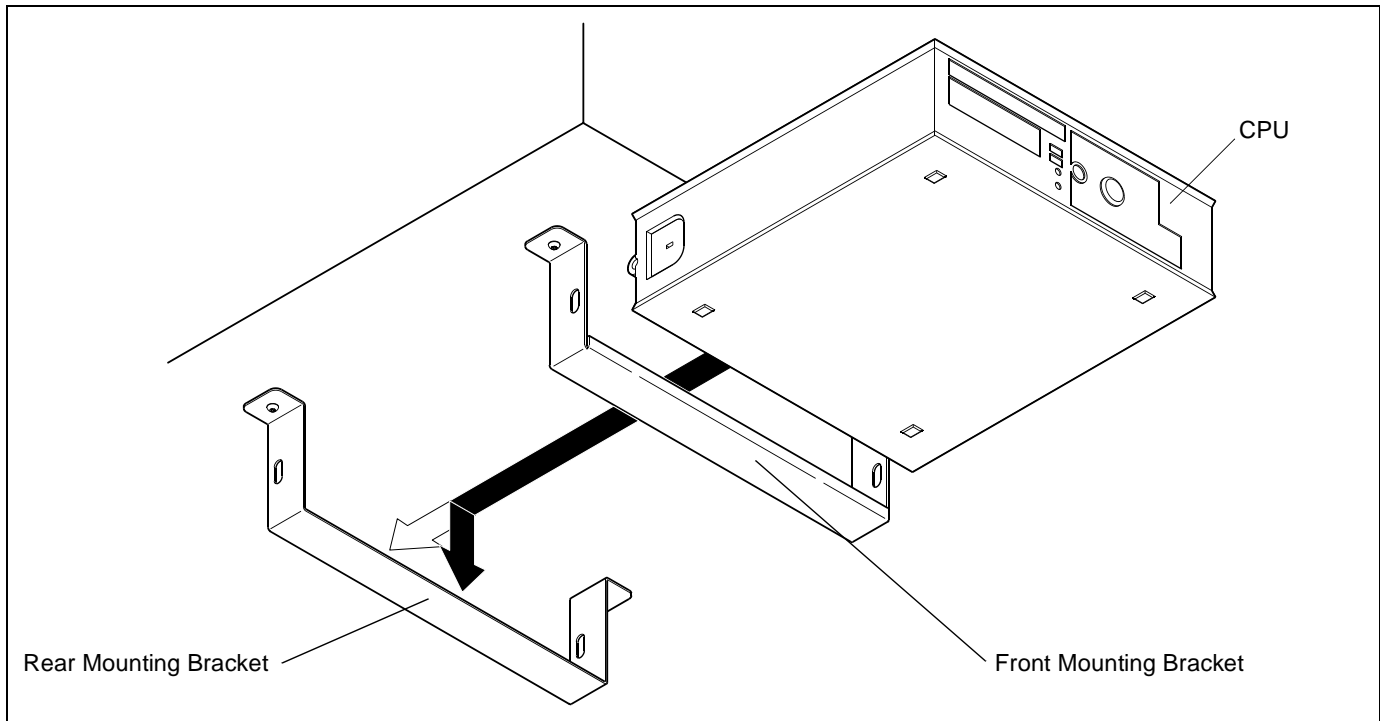

**Figure 4**

- Raise front mounting bracket until CPU is properly seated and tighten two screws to secure front mounting bracket to surface.

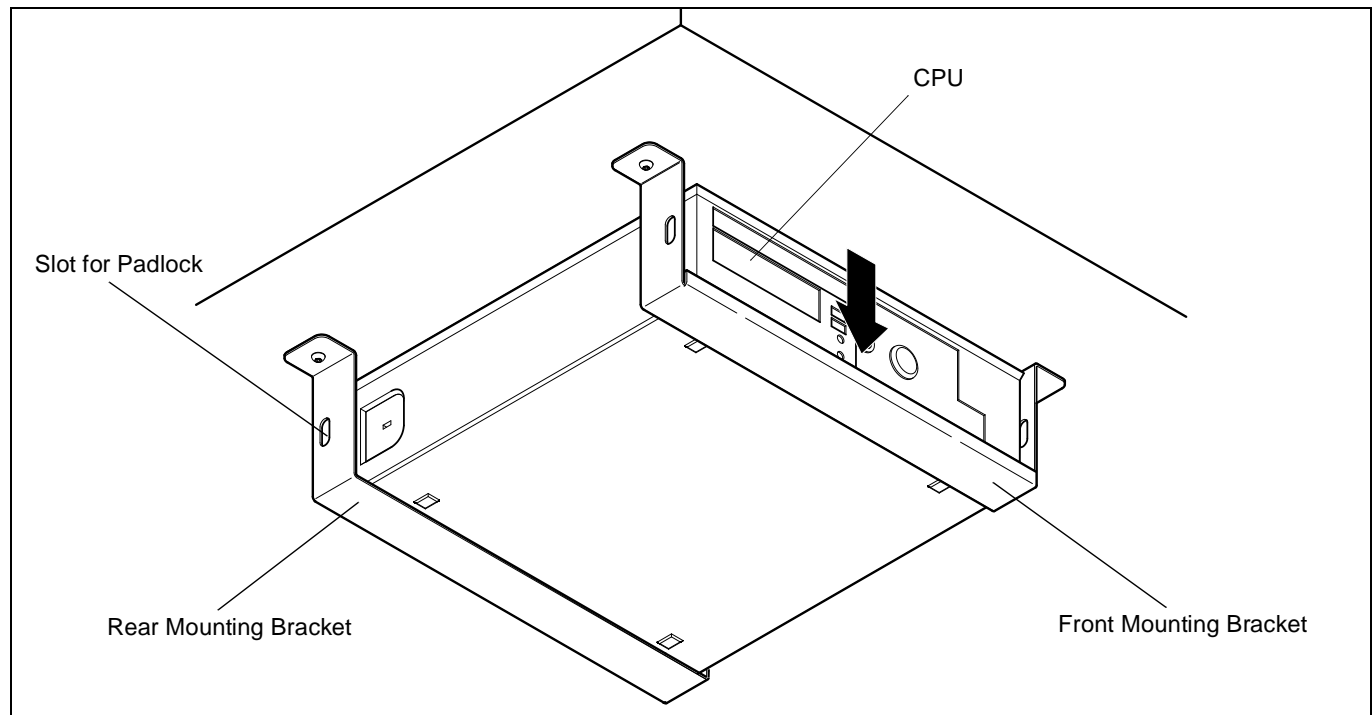

**Figure 5**

- Install paddlock through slot in mounting bracket and locking hole in CPU if desired. (See Figure 5)
- Connect power and signal cables to CPU.





8832-000179  
©2006 Chief Manufacturing  
[www.chiefmfg.com](http://www.chiefmfg.com)  
08/06

<b>USA/International</b>	<b>A</b> 8401 Eagle Creek Parkway, Savage, MN 55378 <b>P</b> 800.582.6480 / 952.894.6280 <b>F</b> 877.894.6918 / 952.894.6918
<b>Europe</b>	<b>A</b> Fellenoord 130 5611 ZB EINDHOVEN, The Netherlands <b>P</b> +31 (0)40 2668620 <b>F</b> +31 (0)40 2668615
<b>Asia Pacific</b>	<b>A</b> Room 30I, Block D, Lily YinDu International Building LuoGang, BuJi Town, Shenzhen, CHINA. Post Code: 518112 深圳市布吉罗岗百合银都国际大厦D栋30I <b>P</b> +86-755-8996 9226 ; 8996 9236 ; 8996 9220 <b>F</b> +86-755-8996 9217