INSTALLATION INSTRUCTIONS

Medium Flat Panel

Single Swing Arm Wall Mount (JWS)

Model MSP-DCCMS

The JWS single swing arm wall mount was designed for mounting a medium sized flat panel display. The JWS can swing out from the wall or fold against the wall, depending on your ergonomic need. The mount itself can be tilted +15°. The amount of tilt left and right depends on the size and location of the display.

The JWS is shipped with the VESA® 100mm/100mm Centris™ interface which is compatible with most medium flat panels. To accommodate the mounting hole patterns on existing medium flat panels that are offered in different sizes, the JWS is supplied with two interface adapters, listed below:

- The 200mm/100mm interface adapter
- The interface adapter that accommodates the 400mm/200mm and 550mm/235mm hole patterns

The JWS will more than likely adapt to your medium flat panel display, providing that your display does not exceed the specified weight rating.

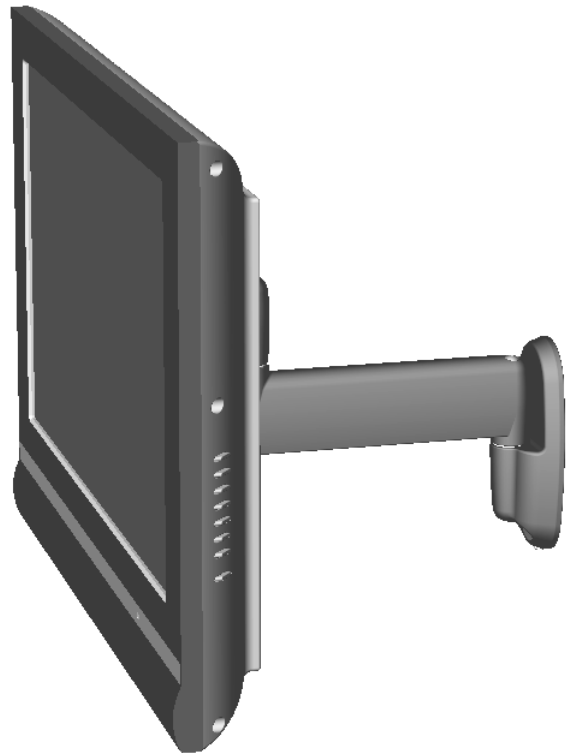

BEFORE YOU BEGIN

CAUTION: To prevent damage to the JWS, which could affect or void the Factory warranty, and to the equipment that will be attached to it, thoroughly study all instructions and illustrations before you begin the installation. Pay particular attention to the “Important Warnings and Cautions” on Page 2.

- The maximum weight to be installed on the JWS wall mount is 75 pounds (34 kg).
- The JWS wall mount is designed to be installed using wall studs or supporting framework. The structure to which the JWS wall mount is anchored must be capable of supporting five times the total weight of the mount and all attached equipment.
- If you have any questions about this installation, contact Chief Manufacturing at 1-800-582-6480.

! IMPORTANT WARNINGS AND CAUTIONS!

WARNING: A WARNING alerts you to the possibility of serious injury or death if you do not follow the instructions.

CAUTION: A CAUTION alerts you to the possibility of damage or destruction of equipment if you do not follow the corresponding instructions.

WARNING: Improper installation can result in serious personal injury! Make sure that the structural members can support a redundant weight factor five times the total weight of the equipment. If not, reinforce the structure before installing the JWS.

WARNING: Be aware also of the potential for personal injury or damage to the unit if it is not adequately mounted.

WARNING: The installer is responsible for verifying that the wall to which the JWS is anchored will safely support the combined load of all attached components or other equipment.

WARNING: The weight of the display placed on the JWS must not exceed 75 lbs. (34 kg), the maximum load capacity of the JWS.

WARNING: Watch for pinch points. Do not put your fingers between movable parts.

WARNING: Make sure the mount and brackets are correctly oriented.

CAUTION: Check the unit for shipping damage before you begin the installation.

DIMENSIONS

Top View

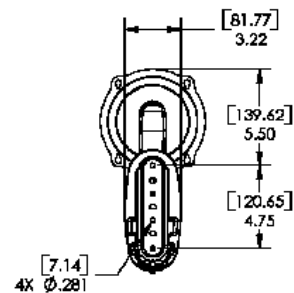
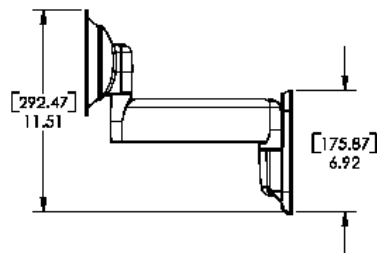
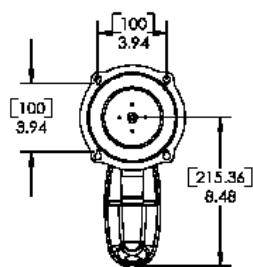
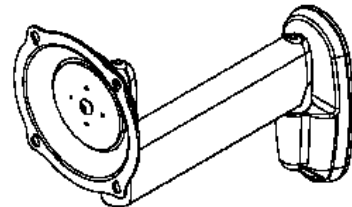
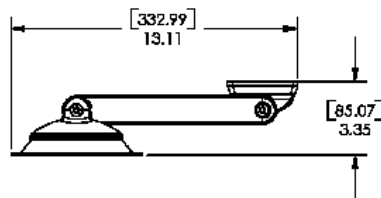
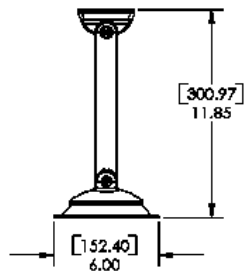

Front View

Side View

Rear View

CONTENTS

IMPORTANT WARNINGS AND CAUTIONS! 2
 DIMENSIONS 2
 TOOLS REQUIRED FOR INSTALLATION 3
 Inspect The Unit Before Installing 3
 SPECIFICATIONS 3
 INTRODUCTION 3
 PARTS 4
 PARTS (Continued) 5
 WALL BRACKET INSTALLATION 6
 Secure Wall Bracket 6
 Attach Mount to Wall Bracket 6
 INSTALLATION (100MM x 100MM) 7
 Flush Mount Centris Bracket to Display 7
 Recess Mount Centris Bracket to Display 7
 INSTALLATION (200MM x 100MM) 8
 Attach Interface Adapter to Display 8
 Attach Display to Centris Bracket 8
 INSTALLATION (400mm x 200MM and 550mm x 235MM) 9
 Attach 400mm x 200mm Interface Adapter 9
 Used for 400mm x 200mm hole patterns. 9
 Attach 550mm x 235mm Interface Adapter 9
 Used for 550mm x 235mm hole patterns. 9
 Attach Display To Centris Bracket 9
 CABLE MANAGEMENT 10
 ADJUSTMENTS 10
 Lateral Tension Adjustment 10
 Pitch Adjustment 10

TOOLS REQUIRED FOR INSTALLATION

- Electric drill and bit set
- Hex wrench set
- Phillips screwdriver
- Level

NOTE: Other tools may be required depending on the mounting surface and method of installation.

Inspect The Unit Before Installing

WARNING: Watch for pinch points. Do not put your fingers between movable parts.

1. Carefully inspect the mount for shipping damage. If any damage is apparent, call your carrier claims agent and do not continue with the installation until the carrier has reviewed the damage.

NOTE: Read all instructions before starting installation.

2. Lay out components to ensure you have all the required parts before proceeding (see JWS drawing on page 4).

SPECIFICATIONS

Table 1 below provides the JWS specifications.

Table 1: JWS Specifications

Depth from Wall	3.35" (85.07mm)
Maximum Extension	11.85" (300.97mm)
Dimensions W x H x D	13.11" x 11.51" x 3.35" (332.99 x 292.47 x 85.07mm)
Weight Capacity	75 lbs (34kg)

INTRODUCTION

The installation process involves three key steps, as follows:

- Select mounting configuration
 - 100 x 100mm Centris mounting (flush and recessed)
 - 200 x 100mm Centris mounting with interface adapter
 - the interface adapter that accommodates two mounting hole patterns: 400mm x 200mm and 550 x 235mm
- Connect cables
- Make adjustments

PARTS

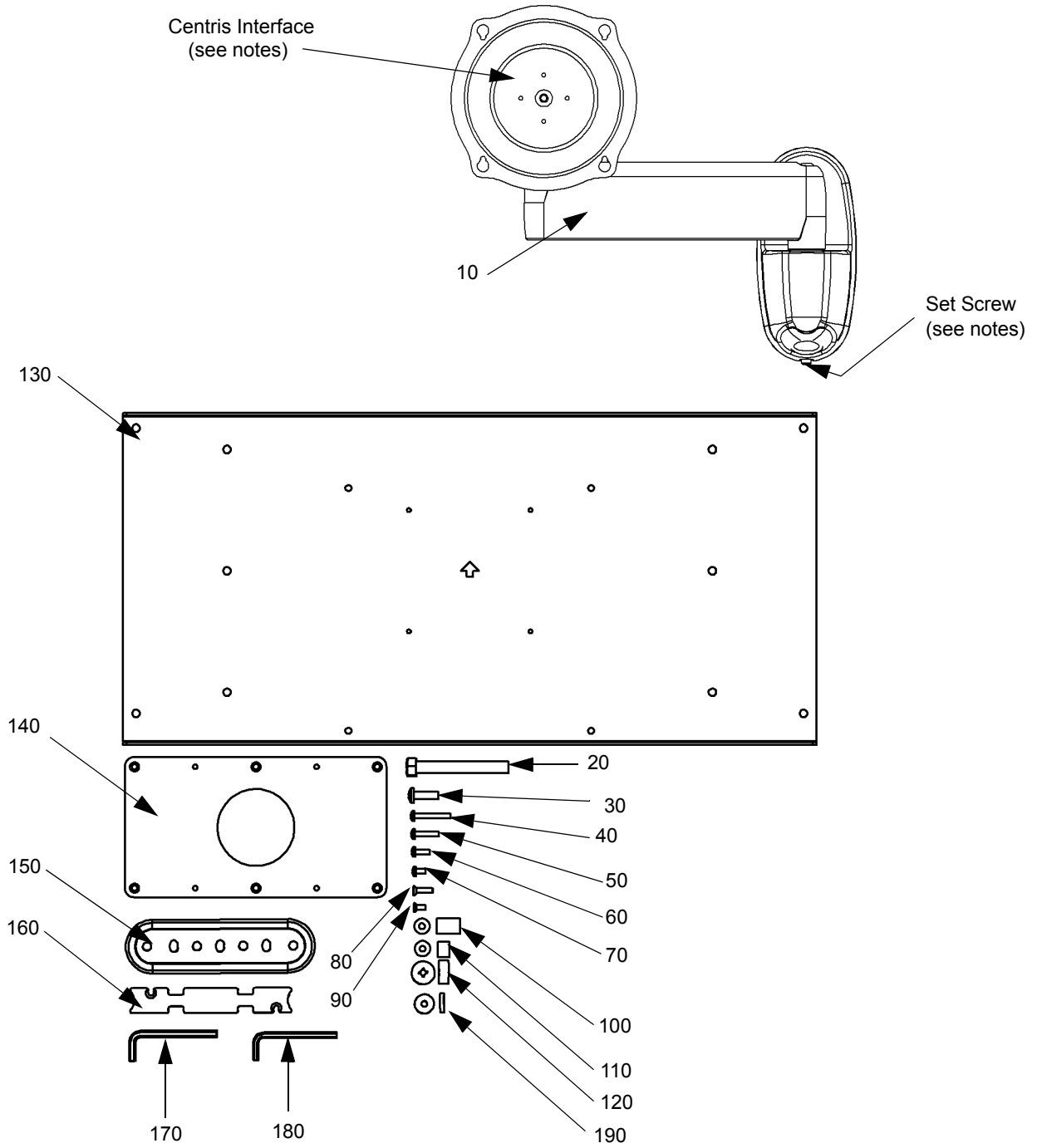

Figure 1: JWS PARTS

PARTS (Continued)

Table 2 below provides a list of the JWS parts.

Table 2: JWP Parts

ITEM NUMBER	DESCRIPTION	QTY	USED WITH NOTES
10	JWS MOUNT	1	
20	3/8" x 3" LAG SCREWS	2	USE WITH 150
30	PHILLIPS PAN HEAD MACHINE SCREW, M6 x 20mm	6	USE WITH 120 AND 130£
40	PHILLIPS PAN HEAD MACHINE SCREW, M4 x 30mm	4	USE WITH 100*
50	PHILLIPS PAN HEAD MACHINE SCREW, M4 x 20mm	4	USE WITH 110**
60	PHILLIPS PAN HEAD MACHINE SCREW, M4 x 12mm	4	USE WITH CENTRIS INTERFACE‡
70	PHILLIPS PAN HEAD MACHINE SCREW, M4 x 8mm	4	USE WITH 140
80	PHILLIPS FLAT HEAD MACHINE SCREW, M4 x 16mm	6	USE WITH 140 and 190
90	PHILLIPS FLAT HEAD MACHINE SCREW, 8-32 x 3/8"	2	USE WITH 160
100	3/4" THICK NYLON RETAINING SPACER	4	USE WITH 40*
110	3/8" THICK NYLON RETAINING SPACER	4	USE WITH 50**
120	5/16" THICK NYLON RETAINING SPACER (.75 Outside Diameter)	6	USE WITH 30
130	INTERFACE ADAPTER (400mm x 200mm and 550mm x 235mm)	1	USE WITH 30 AND 120
140	200mm x 100mm INTERFACE ADAPTER	1	USE WITH 70 AND 80
150	WALL BRACKET	1	USE WITH 20
160	COVER PLATE	1	USE WITH 90
170	WRENCH, 3/16" HEX KEY	1	FOR JOINTS
180	WRENCH, 5/16" HEX KEY	1	
190	SPACER, 1/8" Nylon, Retaining	6	Use with 80

NOTES:

‡The M4 x 12mm screws (60) are used on the Centris interface for flush mount applications.

*The M4 x 30mm screws (40) with spacers (110) are for recessed mount applications.

**M4 x 20mm screws (50) with spacers (100) are for recessed mount applications.

***The six M4 x 16mm screws (80) and six spacers (190) are used to attach the interface adapter (140) to the display.

£The M6 x 20mm screws (30) are used with spacers (120) and the interface adapter (130).

‡The M4 x 8mm screws (70) are also used to attach the Centris interface to the interface adapter (140).

WALL BRACKET INSTALLATION

Secure Wall Bracket

WARNING: It is the responsibility of the installer to verify that the surface to which the mount is anchored will safely support the combined load of all attached components and equipment.

To install the mount:

1. Determine the exact mounting location prior to installation, considering the unit's swing and extension radius.
2. Using the wall bracket (150) as a template, mark the two pilot holes for mounting the wall bracket. (see Figure 2)
3. Drill two 1/4" pilot holes a minimum depth of 2" into the wood stud.

NOTE: Make sure the wall bracket is level before installing the lag bolts.

4. Using a 3/8" socket wrench, install two lag bolts (20) to secure the wall bracket (150) to the wall. Do not overtighten the lag bolts.

IMPORTANT ! : Overtightening lag bolts may cause bracket to compress into soft wall surface, resulting in difficult mount installation or improper engaging of set screw in step 2 below. If this occurs, remove bracket, install 3/8" steel washers as required between bracket and wall surface, and reinstall bracket.

NOTE:

- For a flush mount application, perform the "Attach Mount to Wall Bracket" on page 6 and then perform the "Flush Mount Centris Bracket to Display" on page 7.
- For a recessed mounting application, omit the procedure to "Attach Mount to Wall Bracket" on page 6 and proceed to the "Recess Mount Centris Bracket to Display" on page 7.

Attach Mount to Wall Bracket

1. Align the top of the mount (10) with the top of the wall bracket (150). Push the bottom of the mount against the bottom of the wall bracket until the mount fits snugly in place. See Figure 3.
2. Using the 5/32" hex wrench (180), secure the mount to the wall bracket by tightening the set screw (see Figure 3). Ensure set screw engages *back* side of bracket to properly secure mount.

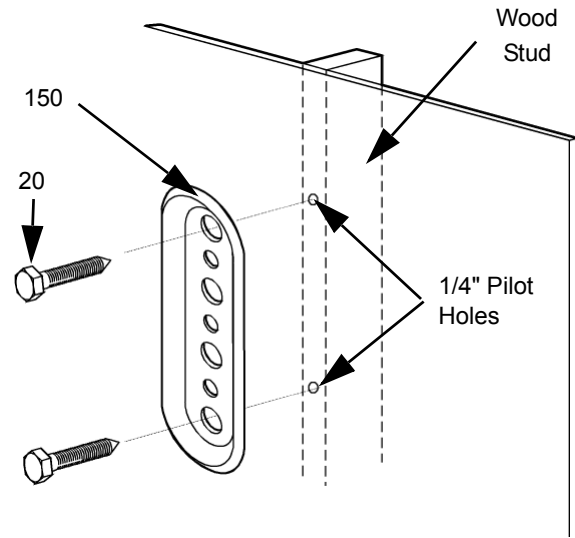

Figure 2: Secure Wall Bracket

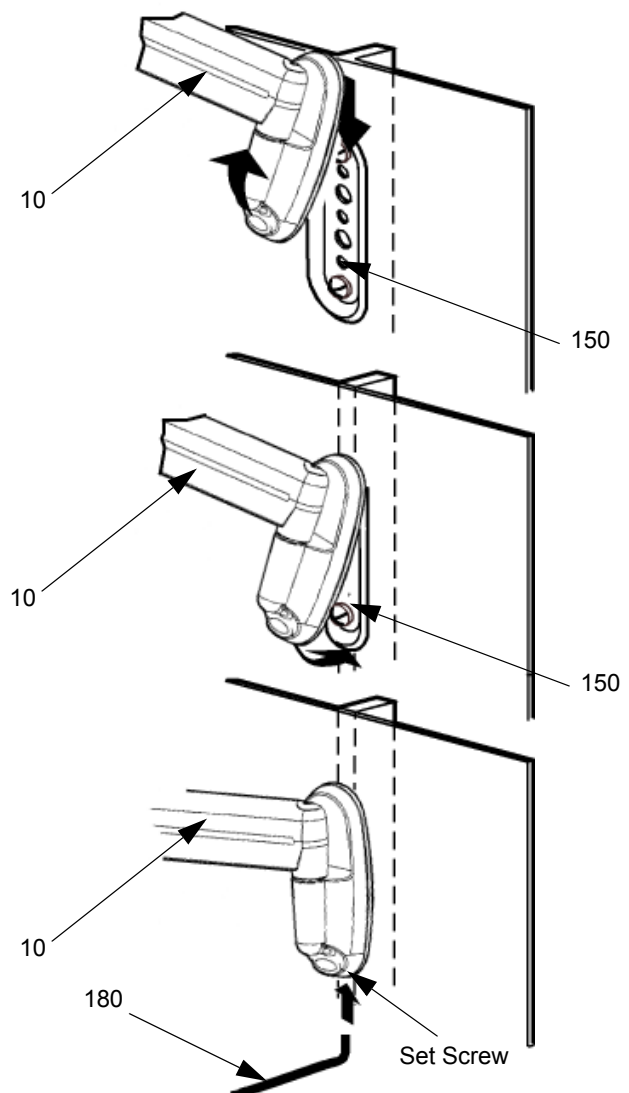

Figure 3: Attach Mount to Wall Bracket

INSTALLATION (100MM x 100MM)

Flush Mount Centris Bracket to Display

1. Install two M4 x 12mm screws (60) into the top mounting holes (not shown) on the display.
2. Align the mounting holes on the Centris bracket with the screws installed on the display. Hang the display on the Centris bracket. (see Figure 4).
3. Install two remaining M4 x 12mm screws (60) into the bottom mounting holes on the display.

Recess Mount Centris Bracket to Display

NOTE: Use one of the following screw and spacer combinations: (40 with 100) or (50 with 110).

CAUTION: If your display uses a screw size other than M4 x 20mm or M4 x 30mm, DO NOT use the M4 x 20mm or M4 x 30mm screws. Using the wrong screws could result in damage to your display.

1. Select four M4 screws (40 or 50) and four retaining spacers (100 or 110) from parts bag.
2. Place display face down on a clean dry surface.
3. Install four M4 screws (40 or 50) into the four mounting holes on centris bracket. (see Figure 5)
4. Slide 4 retaining spacers (100 or 110) onto four M4 screws (40 or 50).
5. Align centris bracket, with screws (40 or 50) and spacers (100 or 110), with mounting holes in display back.
6. Tighten all screws.

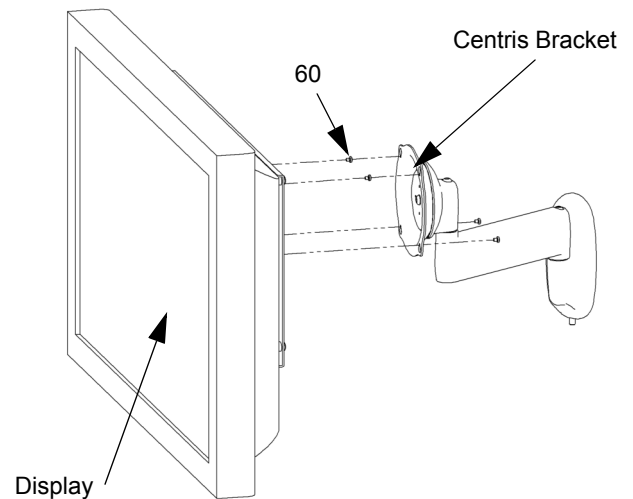

Figure 4: Flush Mount Centris Bracket to Display

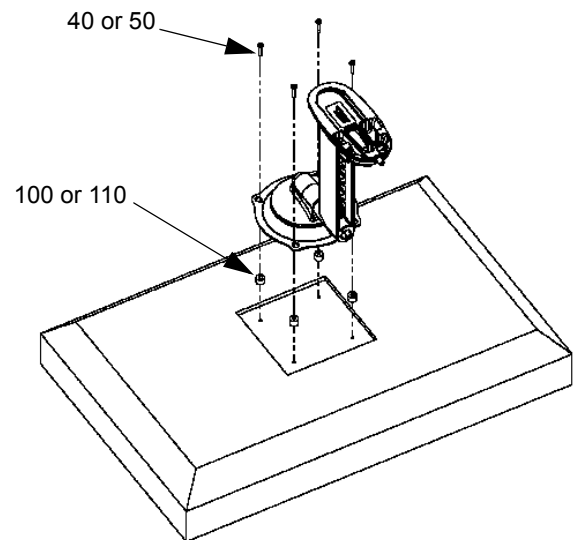

Figure 5: Recess Mount Centris Bracket to Display

INSTALLATION (200MM x 100MM)

Attach Interface Adapter to Display

1. Select six M4 x 16mm screws (80) and six spacers (120).
2. Place display face down on a clean dry surface.
3. Install six M4 screws (80) into the six mounting holes on the interface bracket (140) (see Figure 6).
4. Slide six retaining spacers (120) onto six M4 screws (80).

NOTE: The arrow on the interface bracket (140) must point toward the top of the display.

5. Align interface bracket (140), with screws (80) and spacers (120), and mounting holes in display back.
6. Tighten all screws.

Attach Display to Centris Bracket

1. Start two M4 x 8mm Phillips pan head screws (70) into the top two mounting holes of the previously attached interface bracket (see Figure 7).
2. Hang the mount from the two screws started in Step 1.
3. Install the remaining two M4 x 8mm Phillips pan head screws (70) into the bottom two mounting holes of the display.
4. Secure the display to the mount (Centris bracket) by tightening all four M4 x 8mm Phillips pan head screws (70) (see Figure 7).

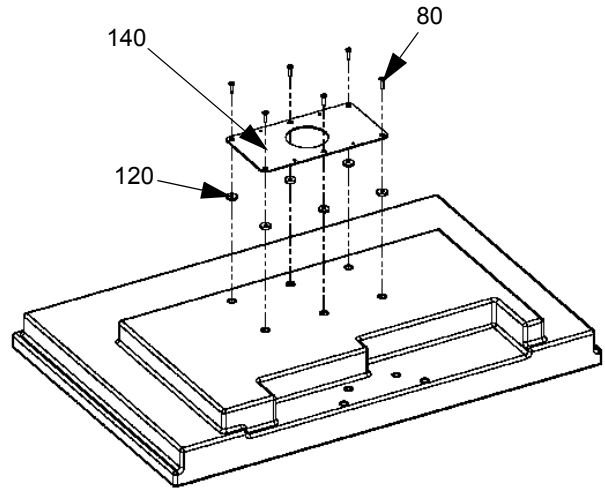

Figure 6: Attach Interface Bracket to Display

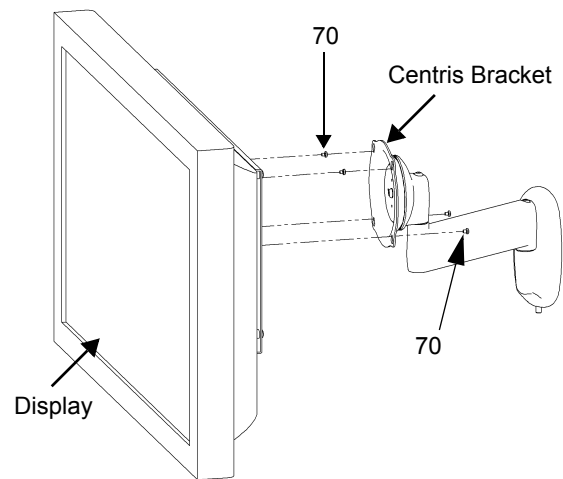

Figure 7: Attach Display to Centris Bracket

INSTALLATION (400mm x 200MM and 550mm x 235MM)

Attach 400mm x 200mm Interface Adapter

Used for 400mm x 200mm hole patterns.

1. Select six M6 x 20mm Phillips pan head screws (30) and six retaining spacers (120).
2. Place display face down on a clean dry surface.
3. Install six M6 x 20mm screw (30) into the six mounting holes on the interface bracket (130). (see Figure 8)
4. Slide six retaining spacers (120) onto six M6 x 20mm screws (30).

NOTE: The arrow on the interface bracket (130) must point toward the top of the display.

5. Align interface bracket (130), with screws (30) and spacers (120), with mounting holes in display back.
6. Tighten all screws.

Attach 550mm x 235mm Interface Adapter

Used for 550mm x 235mm hole patterns.

1. Select four M6 x 20mm Phillips pan head screws (30) and four retaining spacers (120).
2. Place display face down on a clean dry surface.
3. Install four M6 x 20mm screw (30) into the four mounting holes on the interface bracket (130). (see Figure 9)
4. Slide four retaining spacers (120) onto four M6 x 20mm screws (30).

NOTE: The arrow on the interface bracket (130) must point toward the top of the display.

5. Align interface bracket (130), with screws (30) and spacers (120), with mounting holes in display back.
6. Tighten all screws.

Attach Display To Centris Bracket

1. Start two M4 x 8mm Phillips pan head screws (70) into the top two mounting holes of the previously attached interface bracket. (see Figure 10)
2. Hang the mount from the two screws started in Step 1.
3. Install the remaining two M4 x 8mm Phillips pan head screws (70) into the bottom mounting holes of the display.
4. Secure the display to the mount (Centris bracket) by tightening all four M4 x 8mm Phillips pan head screws (70). (see Figure 10)

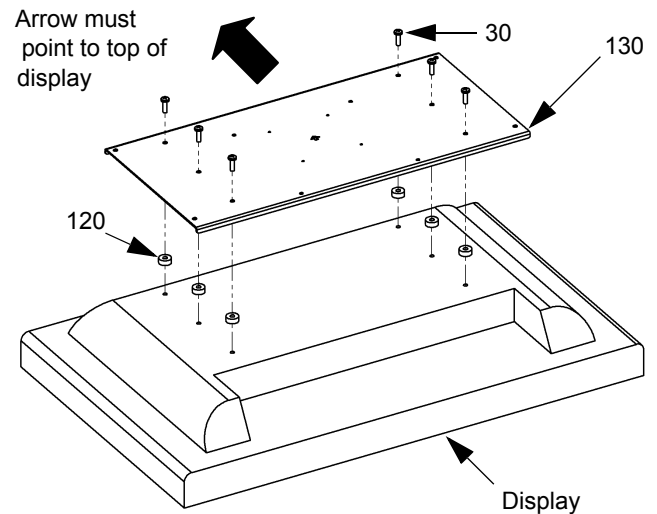

Figure 8: Attach 400mm x 200mm Interface Adapter

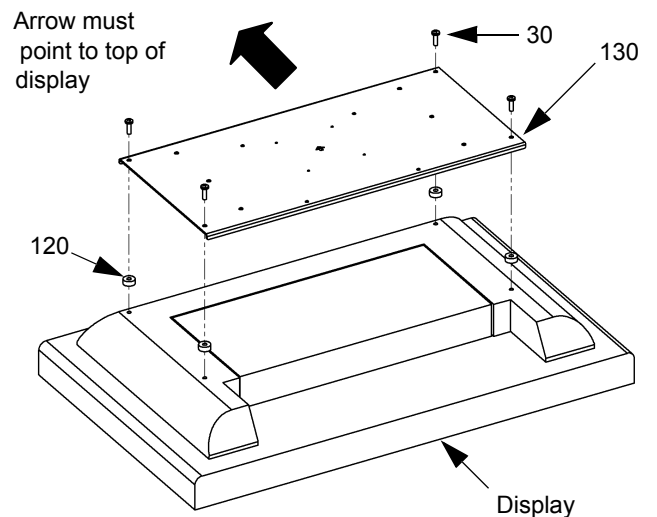

Figure 9: Attach 550mm x 235mm Interface Adapter

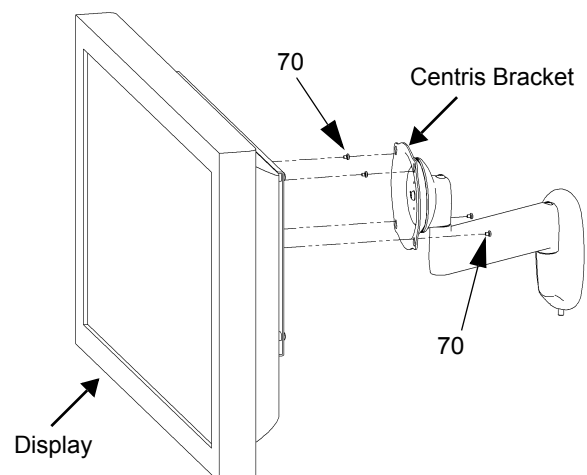

Figure 10: Attach Display to Centris Bracket

CABLE MANAGEMENT

WARNING: Make sure cables do not run through a pinch point.

1. Connect and secure power/audio/video cables.

NOTE: Leave sufficient slack in cables to allow for movement of the display.

2. Secure cables using cover plate (160) and two screws (90) (see Figure 11).

ADJUSTMENTS

Lateral Tension Adjustment

CAUTION: Overtightening adjustment will cause excessive wear.

1. Using a 3/16" hex wrench (170), slightly tighten or loosen lateral tension adjustment bolt (see Figure 12).
2. Check for desired tension.
3. Repeat Steps 1 and 2 until desired tension is obtained.

Pitch Adjustment

CAUTION: Overtightening adjustment screw will cause excessive wear.

NOTE: Remove display to make pitch adjustment.

1. Check adjustment screw on the Centris interface to ensure that the screw is tight (see Figure 13).
2. If needed, use a 3/16" hex wrench (170) to tighten the screw.

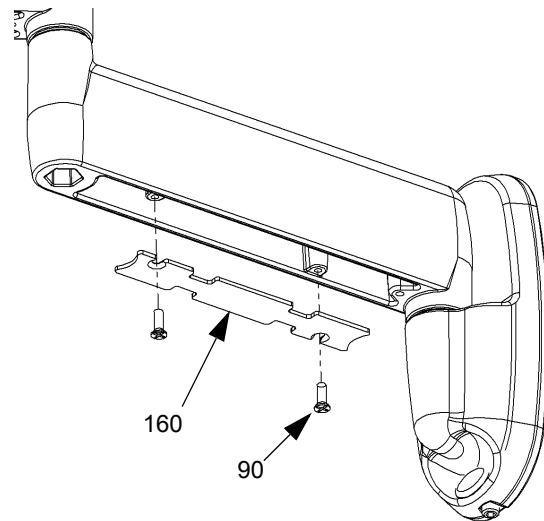

Figure 11: Cable Management

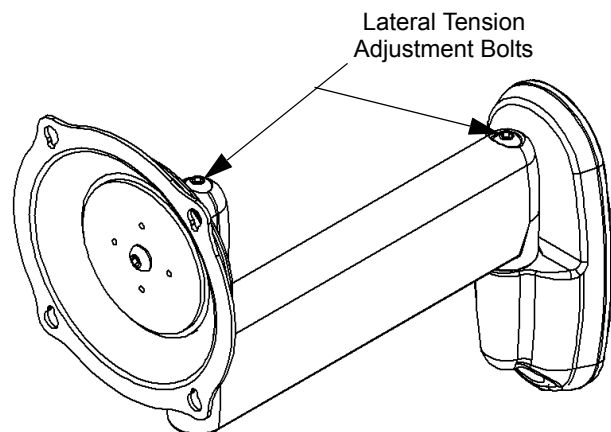

Figure 12: Lateral Tension Adjustment

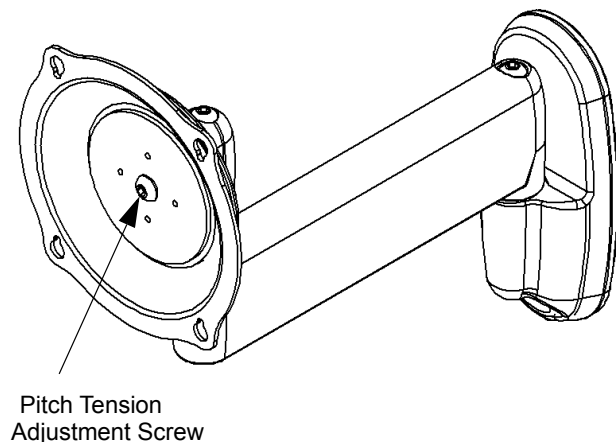

Figure 13: Pitch Adjustment