INSTALLATION INSTRUCTIONS

Part # MSP-DCCPPNR Large Flat Panel Dual Arm Wall Mount

The MSP-DCCPPNR is wall-mounted, rugged, versatile, and installer-friendly. The mount is compatible with the standard (14" x 14") PSB interface bracket in which a display can be mounted in either the landscape or portrait position on the mount.

The dual arms on the MSP-DCCPPNR:

- Extend from the wall 24-7/8" in length
- Pivot up to 90° left or right of center

The standard mount is shipped with the support posts for the dual arms centered in the mount. The support posts can be moved laterally right or left of center to readily accommodate sites with limited wall space. The mount also has two inches of height adjustment. The tilt range for the display is 5° up and 15° down.

The MSP-DCCPPNR was designed for fast installation. After drawing the plumb line and installing the two top lag bolts into the dual wall studs, the installer hangs the mount on its top bracket and installs two lag bolts in the bottom bracket. Next, the installer makes the height adjustment, mounts the display, and connects the power/audio/video cables, which are diverted into the built-in path in the swing-out arms. After making the lateral, rotational, and tilt adjustments, the installation process is complete.

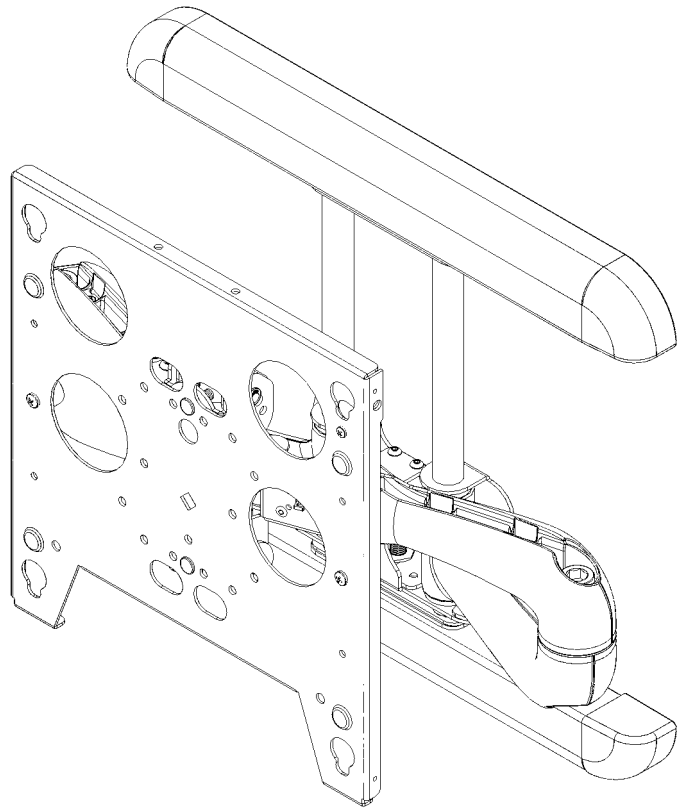

BEFORE YOU BEGIN

- **Caution:** To prevent damage to the PNR, which could affect or void the Factory warranty, and to the equipment that will be attached to it, thoroughly study all instructions and illustrations before you begin the installation. Pay particular attention to the "Important Warnings and Cautions" on Page 2.
- The combined weight of the components installed on the PNR must not exceed 200 lbs. (90.72kg).
- The PNR wall mount must be installed on dual wall studs or supporting framework. The wall to which the PNR is anchored must be capable of supporting *five times* the total weight of the mount and all attached equipment.
- If a defect is discovered after Dell's initial 21 day Customer Satisfaction period, Chief Mfg. will, at its option, repair or replace the product at no charge provided it is returned during the warranty period. Please note contact information for Chief Mfg. listed below:



CHIEF MANUFACTURING INC.
1-800-582-6480 952-894-6280 FAX 952-894-6918
8401 EAGLE CREEK PARKWAY, STE. 700
SAVAGE, MINNESOTA 55378 USA

PART NO. 8805-000146 (Rev. B)
2005 Chief Manufacturing
www.chiefmfg.com
10/05



IMPORTANT WARNINGS AND CAUTIONS!

- WARNING:** A **WARNING** alerts you to the possibility of serious injury or death if you do not follow the instructions.
- CAUTION:** A **CAUTION** alerts you to the possibility of damage or destruction of equipment if you do not follow the corresponding instructions.
- **WARNING:** **Improper installation can result in serious personal injury! Make sure that the structural members can support a redundant weight factor *five times* the total weight of the equipment: if not, reinforce the structure before installing the mount.**
 - **WARNING:** **Be aware also of the potential for personal injury or damage to the unit if it is not adequately mounted.**
 - **WARNING:** **The installer is responsible for verifying that the wall to which the mount is anchored will safely support the combined load of all attached components or other equipment.**
 - **WARNING:** **The weight of the display placed on the mount must not exceed 200 lbs. (90.72kg), the maximum load capacity of the mount.**
 - **WARNING:** **Watch for pinch points. Do not put your fingers between movable parts.**
 - **WARNING:** **Make sure the mount and brackets are correctly oriented.**
 - **WARNING:** **Make sure the flag securing the display is completely lowered at all times *except* when removing or installing the display.**
 - **CAUTION:** Check the unit for shipping damage before you begin the installation.

NOTE: Hardware for attaching this unit to the wall is not supplied.

CONTENTS

IMPORTANT WARNINGS AND CAUTIONS!	2
DIMENSIONAL DRAWING	3
INSPECT THE UNIT BEFORE INSTALLING	4
MOUNT SPECIFICATIONS	4
INTERFACES	4
TOOLS REQUIRED FOR INSTALLATION	4
PARTS LIST	4
MOUNT INSTALLATION	5
Mount the mount	6
Adjust Height on the mount	7
MOUNT THE DISPLAY	8
CABLE MANAGEMENT	9
TENSION ADJUSTMENTS	10
Vertical Tilt Tension Adjustment	10
Lateral Tilt Tension Adjustment	10
Rotational Tilt Tension Adjustment	10
SWING ARM ADJUSTMENTS	11
Adjusting the Swing Arms Slightly Off Center Adjustment	11
Reconfiguring the Swing Arms to the Left or Right of Center	12
REMOVE THE DISPLAY	12
Swing Arm Tension Adjustment.....	13

DIMENSIONAL DRAWING

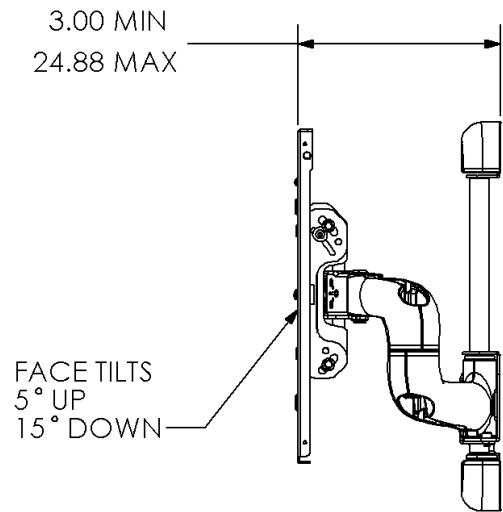
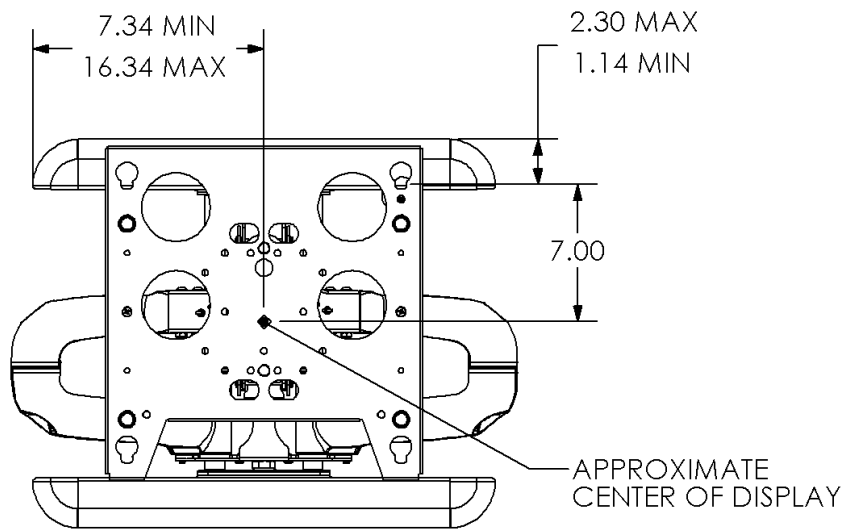
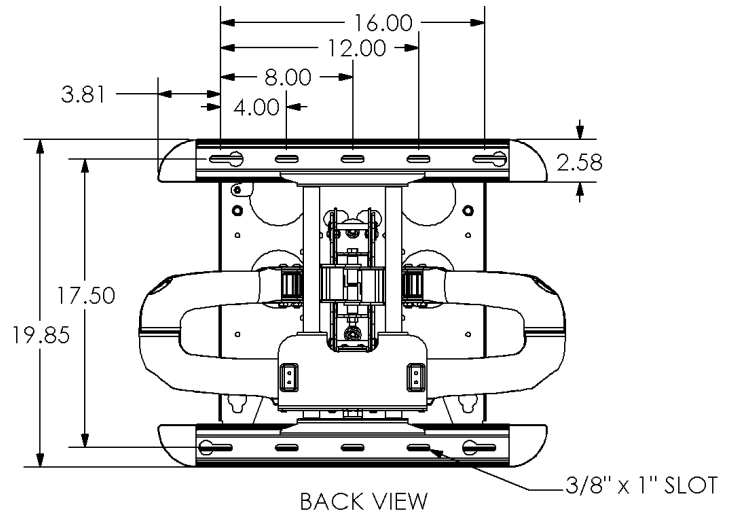
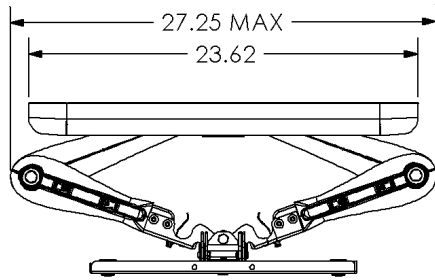

NOTE: CUSTOM INTERAFCE BRACKET NOT SHOWN. THE CUSTOM INTERFACE BRACKET NEEDED FOR YOUR DISPLAY WILL ADD BETWEEN 1/2" AND 2" IN DEPTH AND MAY AFFECT LOCATION OF DISPLAY ON THE MOUNT.

SEE PSB-XXXX DRAWING ALSO.

INSPECT THE UNIT BEFORE INSTALLING

WARNING: Watch for pinch points. Do not put your fingers between movable parts.

- Carefully inspect the mount for shipping damage. If any damage is apparent, call your carrier claims agent and do not continue with the installation until the carrier has reviewed the damage.

NOTE: Read all instructions before starting installation.

- Lay out components to ensure you have all the required parts before proceeding. See “DIMENSIONAL DRAWING” on page 3.

MOUNT SPECIFICATIONS

Table 1 on page 4 provides the mount specifications.

Table 1: Mount Specifications

Model	Max Support Weight	mount Extended from Wall
mount	200 lbs. (90.72kg)	24-7/8”*

*Dimension does not include the PSB interface bracket.

INTERFACES

Table 2 on page 4 provides the applicable mount interfaces.

Table 2: mount Interfaces

Model	Interfaces
mount	14” x 14” Plasma Static Brackets (PSB)

TOOLS REQUIRED FOR INSTALLATION

- Allen wrench set
- Drill and bit set
- Wrench set

NOTE: Other tools may be required depending on the method of installation.

PARTS LIST

Unpack the carton and verify the contents listed in Table 3 on page 4. If you are missing any of the listed parts, contact Customer Service at: 1-800-582-6480.

Table 3: Parts List

REF	DESCRIPTION	QTY
10	Wall Mount	1
20	Cover Plates	2
30	End Caps	4
40	Adjustment Wrench (not shown)	1
50	Tiewraps	12
—	Lag Bolts (required, not supplied)	4
—	Flat Washer (required, not supplied)	4

MOUNT INSTALLATION

WARNING: Improper installation can result in serious personal injury!

WARNING: It is the responsibility of the installer to verify that the wall to which the mount is anchored will safely support *five times* the combined load of all attached components and equipment. If not, reinforce the structure before installing the mount.

Locate two wood studs 16" apart on center

1. Determine the exact mounting location prior to installation, considering screen size and the unit's total swing arm radius. Keep in mind that the mount must be mounted to wood studs that are 16" apart on center.

NOTE: Mount the mount between parallel wall studs or other supporting framework that is vertical or horizontal.

2. Using a stud sensor, locate the two wood studs where you will install the mount.
3. Draw a level plumb line to indicate the desired height of the top mounting bracket.
4. With an assistant, lift and hold the mount against wall. Use a pencil, awl, or small nail to mark the mounting holes where two pilot holes will be drilled into the center of the wood studs. Make sure the mounting holes are level.

5. With an assistant, lay the mount down on the floor.
6. Drill two pilot holes where the mounting holes were marked for anchoring the top bracket on the mount. See Figure 1.

NOTE: Do not tighten the lag bolts down at this time. Leave enough space between the wall and lag bolts to hang the mount.

7. Install two lag bolts and two flat washers, in the pilot holes drilled in step 6.

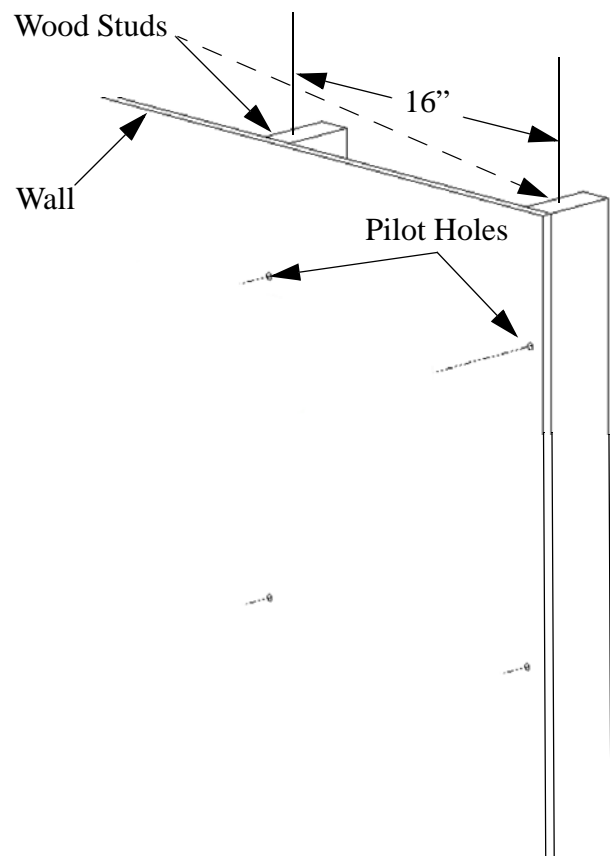

Figure 1. Two Wood Studs 16" Apart On Center

Mount the mount

1. Mount the top bracket on the mount, as follows:

WARNING: Improper installation can result in serious personal injury!

- a. With an assistant, lift and hang the mount on the two lag bolts and washers previously installed on the wall. See Figure 2.

NOTE: Make sure washers are installed in front of the top bracket, not behind the bracket.

- b. Slide the mount into the desired position on the wall and tighten the two lag bolts.
2. Mount the bottom bracket on the mount, as follows:

- a. Mark the two mounting holes in the bottom mounting bracket (see Figure 3). Make sure to align the holes parallel to the holes drilled in the top bracket.
- b. Drill two pilot holes in the wall studs.
- c. Install two lag bolts and two washers into the pilot holes.
- d. Tighten the two lag bolts.



Figure 2. Mount mount on Lag Bolts

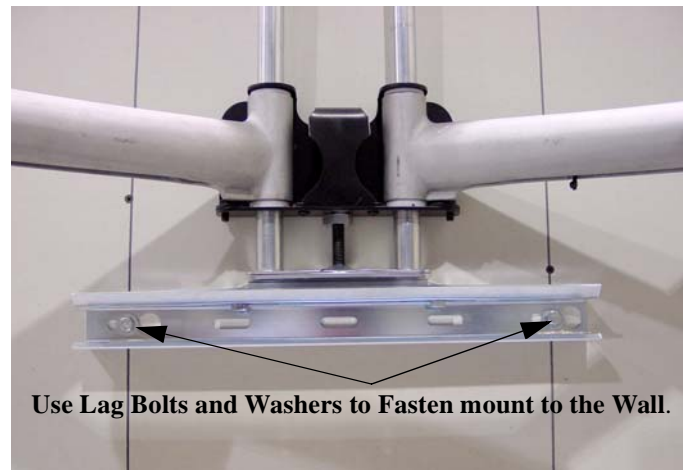

Figure 3. Mount Bottom Bracket on mount

Adjust Height on the mount

NOTE: Height adjustment range up to 2 inches.

To adjust the mount height, do the following:

1. Check mount for the desired height. If needed, use the adjustment wrench (40) to adjust the mount height.
2. To adjust the mount height, do the following:
 - Turn adjustment nut (see Figure 4) clockwise (CW) to lower the unit height, or
 - Turn adjustment nut counterclockwise (CCW) to raise the unit height.

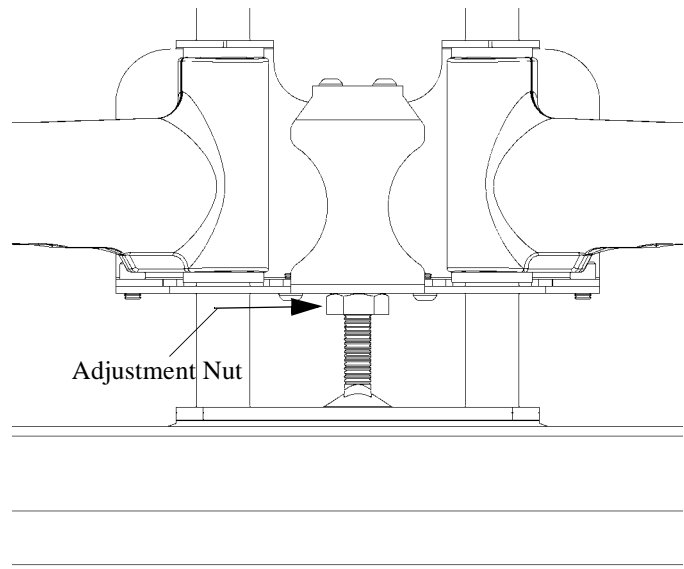

- 1) Check mount height.
- 2) To adjust height, turn adjustment screw, as follows:
 - CW lowers the unit
 - CCW raises the unit

Figure 4. Adjust Height

Install Cover Plates and End Caps

NOTE: The cover plates and end caps have pressure fitting ends that lock in place with each other.

1. Install cover plate (20) over the top bracket. See Figure 5.
2. Install end cap (30) on the cover plate (20). See Figure 5.
3. Repeat steps 1 and 2 for the bottom mounting bracket. See Figure 5.

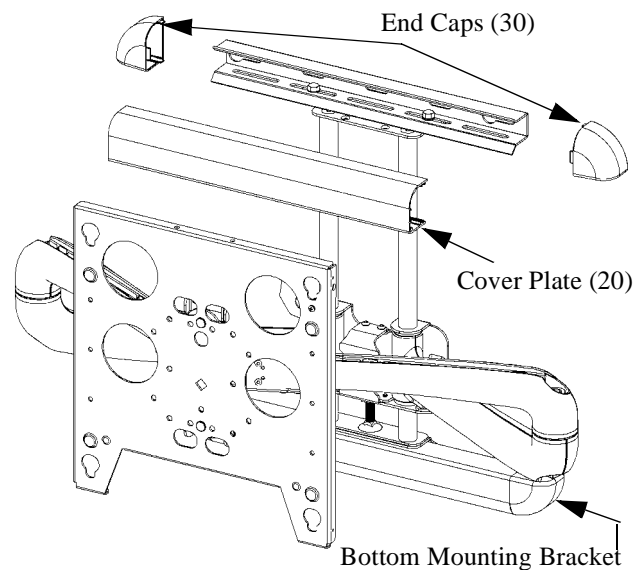

Figure 5. Install Cover Plates and End Caps

MOUNT THE DISPLAY

1. Make sure power is not supplied (turned off) to the display and the locking device is in the unlocked (down) position (see Figure 6) before attempting to mount the display.
2. Following the instructions for mounting the PSB interface bracket of your specific plasma display panel, install the mounting bracket on your plasma display panel.

WARNING: Watch for pinch points. Do not put your fingers between movable parts.

3. With an assistant, slide the display down over the mount. Make sure buttons of PSB interface bracket fully engage all teardrop slots of the mount.
4. Secure the mounting bracket to the mount by completely engaging the locking device (see Figure 6).

WARNING: Make sure the locking device securing the display is completely engaged at all times except when removing or installing the display. The locking device must be completely engaged during installation/removal of cables when the display is mounted.

NOTE: A padlock may be used on the locking device for increased security.

5. Connect and secure power/audio/video cables, making sure to leave sufficient slack to allow for movement of the swing arms.

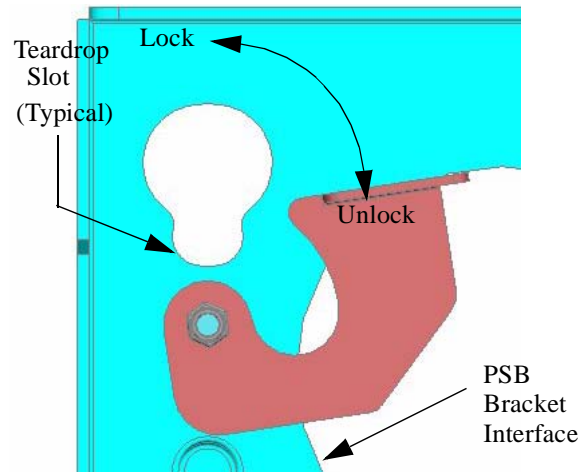

Figure 6. Locking Device

CABLE MANAGEMENT

WARNING: Make sure your cables do not run through a pinch point.

1. Route power/audio/video cables through the cable channel in top arm (see Figure 7), allowing sufficient slack in cables for extension and avoiding pinch points, and secure cables using two clips and two tiwraps (50, not shown).
2. Route power/audio/video cables along bottom arm (see Figure 8), using tiwraps (50, not shown) to secure cables to each arm, and through cable channel.

CAUTION: To prevent equipment damage, do not route cables through holes in the display mounting plate.

3. Route power/audio/video cables to an open area behind the mounting plate (not shown). Leave a sufficient amount of slack in cables to allow for connection and extension where needed.



Figure 7. Cable Management Channel (Top)

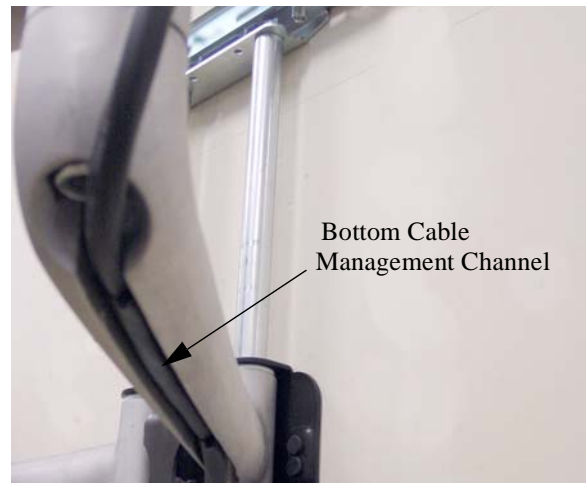

Figure 8. Cable Management Channel (Bottom)

TENSION ADJUSTMENTS

Vertical Tilt Tension Adjustment

1. Using 5/32" Allen wrench, slightly tighten or loosen two screws, one on each side, equally (see Figure 9).
2. With display mounted, check for desired vertical tilt tension.
3. Repeat Step 1 and Step 2 until desired vertical tilt tension is obtained.

Lateral Tilt Tension Adjustment

CAUTION: Overtightening lateral adjustment will cause excessive wear and may distort adjustment components.

1. Using a 9/16" wrench, slightly tighten or loosen lateral tilt tension adjustment nut (see Figure 10).
2. Mount the display and check for desired tilt tension.
3. Repeat Steps 1 and 2 until desired tilt tension is obtained.

Rotational Tilt Tension Adjustment

1. If necessary, loosen or tighten bottom rotational tilt tension adjustment nut (see Figure 11).
2. Mount the display and check for desired rotational tilt tension.
3. Repeat Steps 1 and 2 until desired rotational tilt tension is obtained.

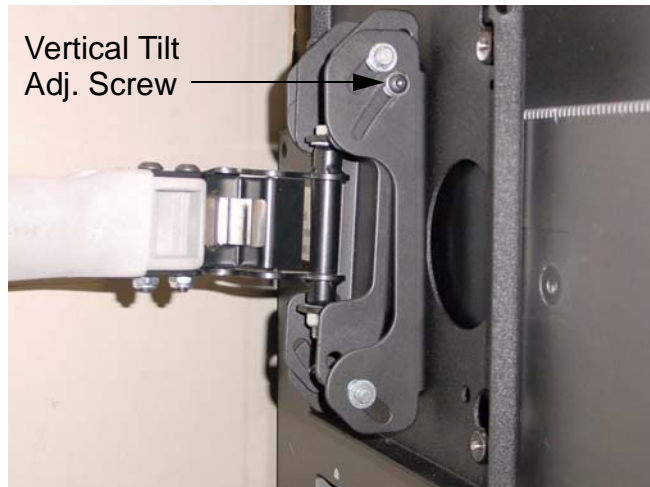

Figure 9. Vertical Tilt

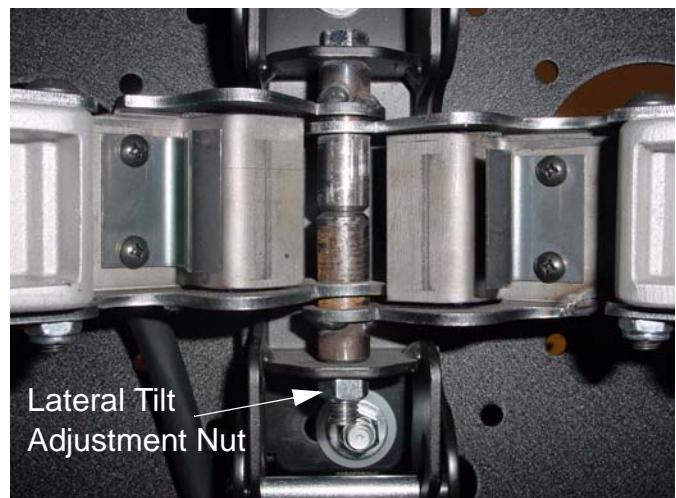

Figure 10. Lateral Tilt

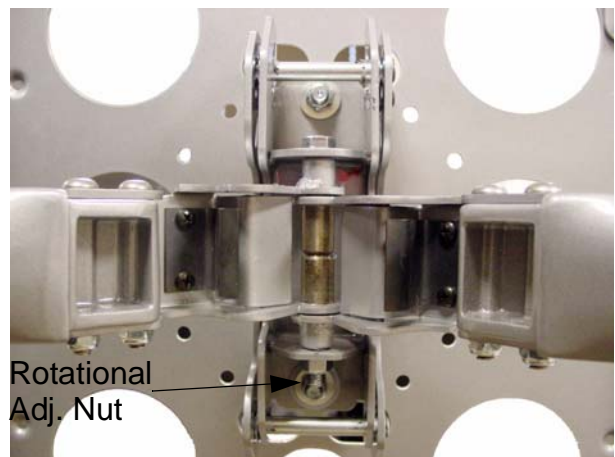

Figure 11. Rotational Adjustment

SWING ARM ADJUSTMENTS

The dual swing arms are shipped installed in the center of the top and bottom mounting brackets, which is the standard mounting configuration.

The top and bottom mounting brackets have slotted holes, allowing for lateral adjustment of the dual swing arms.

After the top and bottom mounting brackets have been installed between two wood studs 16" on center, the swing arms can be adjusted or moved off center, depending on the location of the mount, the size of the display, and the lateral movement needed to rotate the display.

The swing arms can be adjusted, as follows:

- **Adjusting the Swing Arms Off-Center**

With no disassembly required, you can adjust the swing arms up to 1-inch to the left of center or up to 1-inch to the right of center.

- **Reconfiguring the Swing Arms Left of Center**

With some disassembly and re-assembly required, you can move the swing arms to the left of center by reconfiguring the mount. Use the first and third slotted holes in the top and bottom mounting brackets.

- **Reconfiguring the Swing Arms Right of Center**

With some disassembly and re-assembly, you can move the swing arms to the right of center by reconfiguring the mount. Use the third and fifth slotted holes in the top and bottom mounting brackets.

Adjusting the Swing Arms Off Center

Perform this procedure to adjust the dual swing arm mount configuration.

1. Remove the display from the mount.
2. Loosen four bolts (two on the top and two on the bottom) securing the swing arm assembly to the top and bottom mounting brackets (see Figure 12).
3. Move the swing arm assembly to desired location.
4. Tighten the bolts.
5. Install the display on the mount.

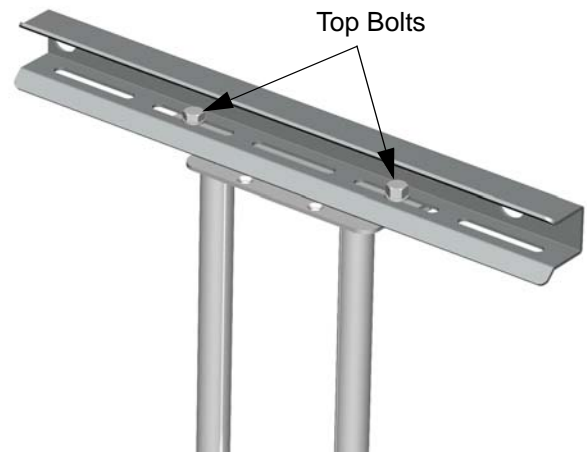

Figure 12. Swing Arm Adjustment – Slightly Off Center

Reconfiguring the Swing Arms to the Left or Right of Center

Perform this procedure to change of the dual swing arm mount configuration.

1. Remove the display from the mount.
2. Remove four bolts (two on the top and two on the bottom) securing the swing arm assembly to the top and bottom mounting brackets (see Figure 13).

WARNING: The next step will release the arm assembly from the mount. The arms and plate may fall if you are not careful.

3. Move the swing arm assembly to desired location.
 - For left of center, see Figure 13.
 - For right of center, see Figure 14.
4. Install retaining pin assemblies (one top and one bottom) and secure using two bolts (one top and one bottom).
5. Install four bolts (two on the top and two on the bottom) to secure the swing arm assembly to the top and bottom mounting brackets (see Figure 14).
6. Tighten the bolts.
7. Install the display on the mount.

REMOVE THE DISPLAY

Perform this procedure when maintenance is required.

WARNING: Plasma screens are heavy and extremely fragile. Exercise caution when removing or installing the plasma screen to avoid serious injury.

1. Disconnect power/audio/video cables.
2. Release the locking device (see Figure 6).
3. Using two people, lift the display up from the PNR.

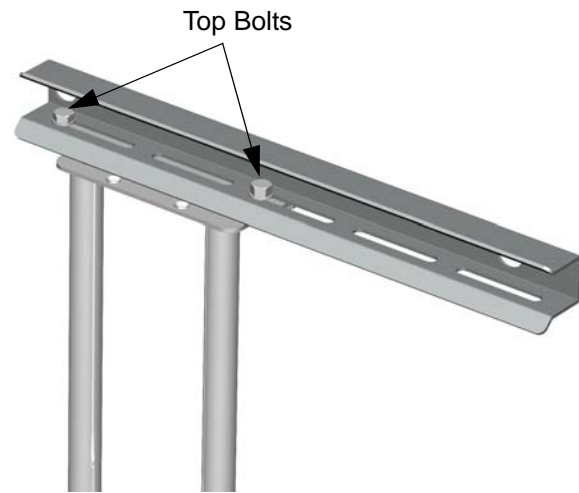

Figure 13. Adjust Swing Arm – Left of Center



Figure 14. Adjust Swing Arm – Right of Center

SWING ARM TENSION ADJUSTMENT

Swing arm tension is pre-set at the factory and is adjusted to accommodate displays with weights near the top of the mounts capacity.

If smaller displays are used it may be difficult to reposition the display after mounting. Swing arm tension can be adjusted to compensate for smaller display by:

NOTE: The display must be mounted prior to adjusting swing arm tension.

1. Locate the adjustment bar and wrench provided with the mount.
2. Place adjustment bar into socket head cap screw located at swing arm pivot point. (see figure 15)

NOTE: The display may need to be repositioned in order to gain access to the tension adjustment screw(s).

3. Using the wrench provided with the mount, turn adjustment bar clockwise to increase swing arm tension or counterclockwise to reduce swing arm tension. (see figure 16) and (see figure 17)

NOTE: Small adjustments of 1/8 turn or less are typically all that is required to achieve desired tension.

4. Check swing arm tension. If desired tension is present, tension adjustment is complete. If additional tension adjustment is required, repeat steps 2 and 3 until desired tension is achieved.

NOTE: If changing from a smaller display to a larger display may be necessary to increase swing arm tension.

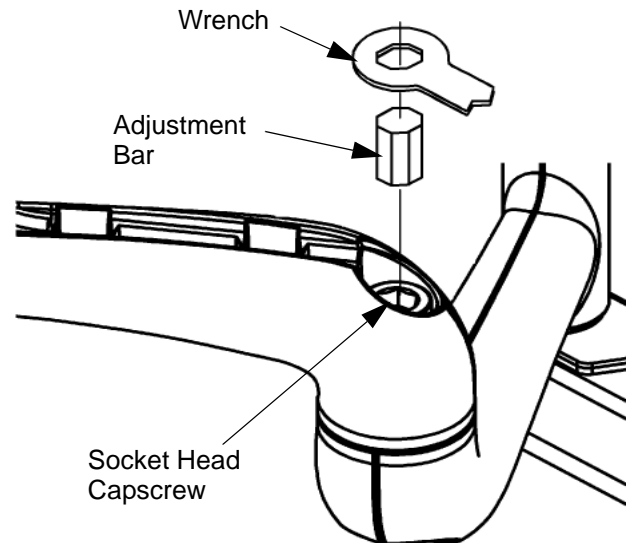

Figure 15. Pivot Arm Tension Adjustment

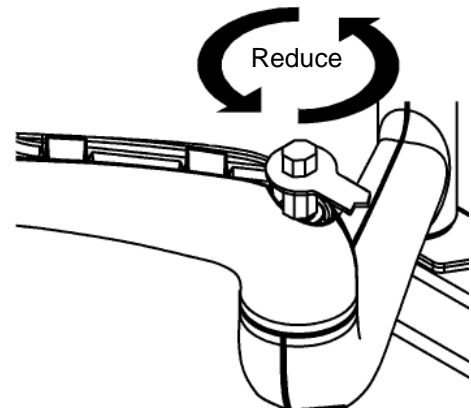

Figure 16. Reduce Swing Arm Tension

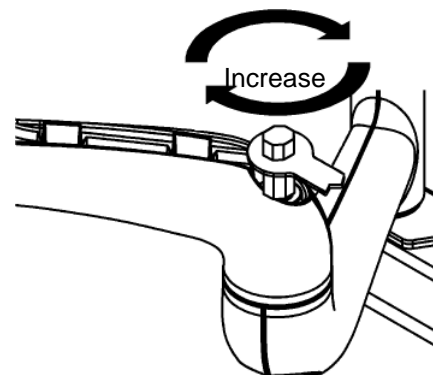

Figure 17. Increase Swing Arm Tension

