

---

# INSTALLATION INSTRUCTIONS

---

## MSP-MSBSONY DISPLAY MOUNTING BRACKET

Prior to assembly, unpack carton completely and verify contents.

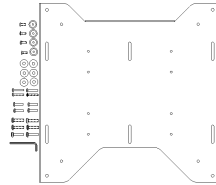

Figure 1

- |  |  |
|--|--|
| (1) Interface Bracket                          | (4) Mounting Buttons-10-24 Tapped      |
| (4) 10-24 Button Head Cap Screws               | (6) .75 x .266 x .313 Nylon Spacers    |
| (4) M4 x 25mm Phillips Head Cap Screws – Black | (4) M5 x 20mm Phillips Head Cap Screws |
| (6) M6 x 25mm Phillips Head Cap Screws – Black | (1) 1/8" Allen Key                     |

BEFORE PROCEEDING, READ INSTALLATION INSTRUCTIONS COMPLETELY

**CAUTION!** DISPLAYS ARE EXTREMELY FRAGILE.

**WARNING!** ALL COMPONENTS MUST BE SECURELY FASTENED TO A STRUCTURAL MEMBER CAPABLE OF SUPPORTING 4 TIMES THE COMBINED WEIGHT OF ALL COMPONENTS PLUS THE EQUIPMENT BEING MOUNTED. IF IT CANNOT SUPPORT THIS WEIGHT, THE STRUCTURE MUST BE REINFORCED. THE MAXIMUM WEIGHT TO BE INSTALLED ON THE INTERFACE IS 75 POUNDS (34.0 KG).

**For screens using a 200mm X 100mm Mounting Pattern (26" Screens), follow Steps 1 & 2 below. For screens that use a 330mm X 330mm, 400mm x 200mm or 400mm X 400mm pattern, follow instructions on next page.**

1. Using the M4 x 25mm Phillips head cap screws, attach mounting buttons directly to back of display (four places) (see Figure 2 & Figure 3). Do not over tighten screws.

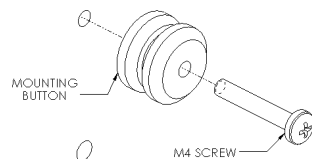

Figure 2

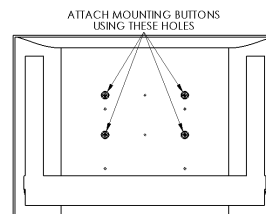

Figure 3

2. Follow mount instructions for installation of screen.

---

**SONY**

**Sony Electronics, Inc.**  
1 Sony Drive, Park Ridge, NJ 07656  
201-930-1000 [www.sony.com/displaysystems](http://www.sony.com/displaysystems)

8832-000186 Rev B  
08/08

## Interface Installation for 32" and 40" screens using 330mm x 330mm, 400mm x 200mm or 400mm X 400mm mounting patterns.

- Using a 10-24 button head cap screw inserted from back side of bracket, secure mounting button, with chamfered hole of mounting button (larger surface) facing bracket, to bracket (four places) (see Figure 4). If installing screen on the MSP-SPOM1 or CH-SMPW swing arm mount, install buttons in the 200mm x 100mm pattern (See Figure 5a). If installing screen on any other mount, install buttons in the 200mm x 200mm pattern (See Figure 5b). Make sure bends of interface bracket face away from buttons.

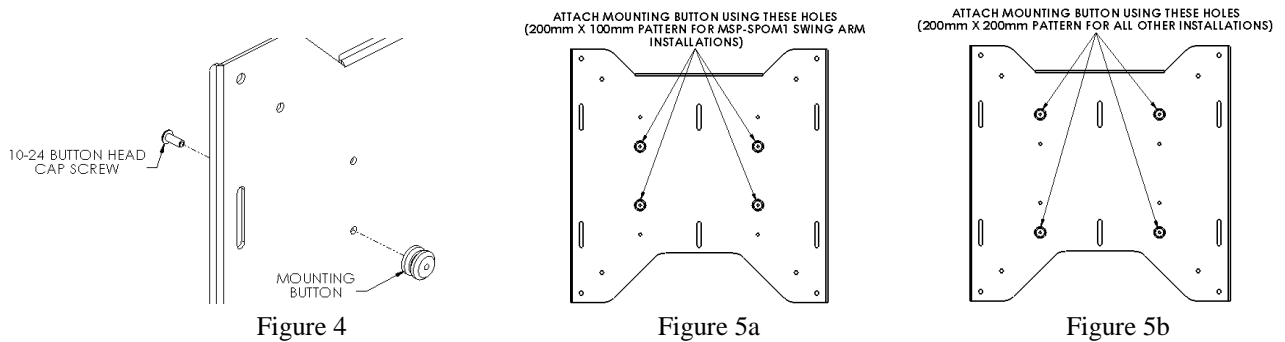

- Place Nylon spacers over mounting holes on back of screen. Attach mounting brackets to the display using either the M5 or M6 screws depending on thread diameter of screen (see Figure 6 & Figure 7a, Figure 7b or Figure 7c).
- With the aid of another person, lift your display up to the CH-SMPW, aligning buttons of mounting brackets with slots in the CH-SMPW.
- Lower safety latch on the CH-SMPW to secure your display, making sure latch is completely engaged.

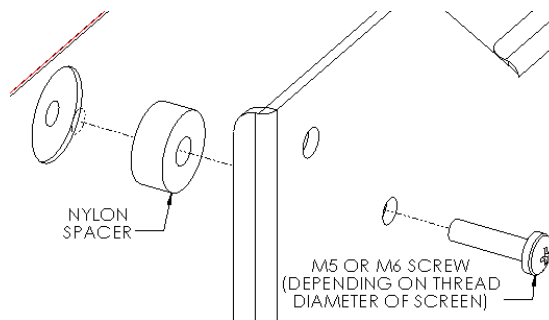

Figure 6

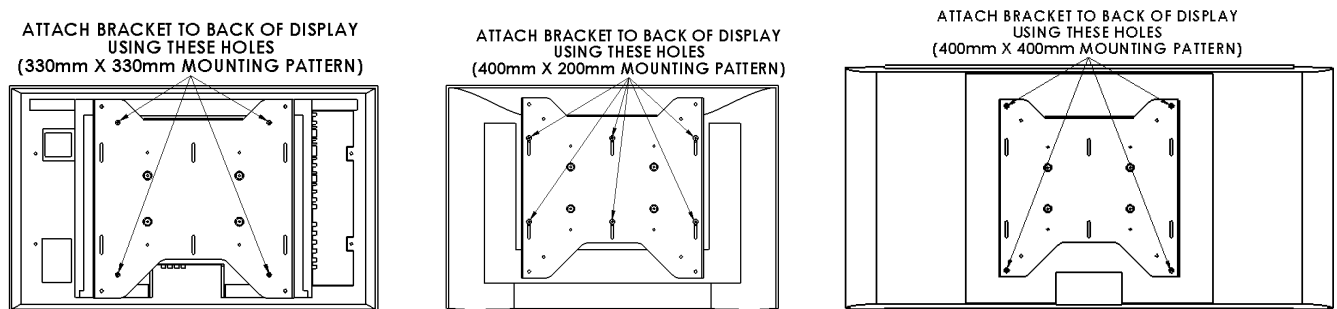

Figure 7a

Figure 7b

Figure 7c