

INSTRUCTION MANUAL

Model MSP-PSBTW200 Flat Panel Display Wall Mount Interface Brackets

The Model MSP-PSBTW200 is an interface for use with static and tilt wall mounts. Display mounting is made simple, safe, and secure using Chief's exclusive Q-latch™ Mounting System.

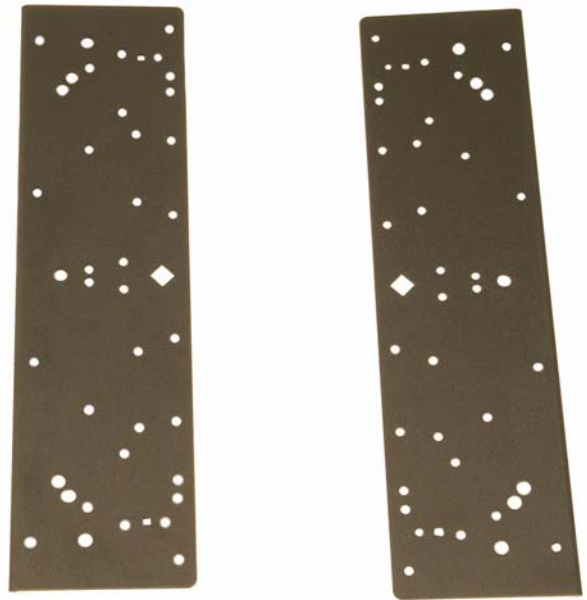

BEFORE YOU BEGIN

- **CAUTION:**To prevent damage to the mount, which could affect or void the Factory warranty, thoroughly study all instructions and illustrations before you begin to install the mount brackets. Pay particular attention to the "Important Precautions" on Page 1.
- If you have any questions about this installation, contact Chief Manufacturing at 1-800-582-6480 or 952-582-6480.



IMPORTANT WARNINGS and CAUTIONS!

- WARNING:** A **WARNING** alerts you to the possibility of serious injury or death if you do not follow the instructions.
- CAUTION:** A **CAUTION** alerts you to the possibility of damage or destruction of equipment if you do not follow the corresponding instructions.
- **WARNING:** Improper installation can result in serious personal injury! Make sure that the mounting surface structural members can support a redundant weight factor *five times* the total weight of the equipment: if not, reinforce the mounting surface structural members before installing the mount.
 - **WARNING:** You must use proper attaching hardware and installation procedures. Failure to use proper attaching hardware and installation procedures may result in equipment damage or serious personal injury.
 - **WARNING:** Be aware of the potential for personal injury or damage to the unit if it is not adequately mounted.
 - **WARNING:** The installer is responsible for verifying that the mounting surface structural members to which the mount is anchored will safely support the combined load of all attached components or other equipment.
 - **WARNING:** The combined weight of the display panel must not exceed 150 lbs. (68.04 kg), the maximum load capacity of the mount.
 - **CAUTION:** Check the unit for shipping damage before you begin the installation.
 - **CAUTION:** Overtightening mounting screws may damage your Large Flat Panel display.

TOOLS REQUIRED FOR INSTALLATION

- Phillips screwdrivers, No. 1 and No. 2
- Adjustable wrench

NOTE: Other tools may be required depending on the method of installation.

CONTENTS

	Page
INSPECT THE BRACKET BEFORE INSTALLING	3
SELECT DISPLAY MODEL AND DETERMINE PARTS	4
ATTACH MOUNTING BUTTONS	5
DETERMINE BRACKET INSTALLATION PROCEDURES	6
Group 1 Installation Procedures	6
Group 2 Installation Procedures	7
Group 3 Installation Procedures	8
Group 4 Installation Procedures	9
Group 5 Installation Procedures	10
Group 6 Installation Procedures	11

INSPECT THE BRACKET BEFORE INSTALLING

- Carefully inspect the interface brackets (see Figure 1) for shipping damage. If any damage is apparent, call your carrier claims agent and do not continue with the installation until the carrier has reviewed the damage.

NOTE: Read all assembly instructions before starting assembly.

- Carefully inspect all parts bags to ensure all components are contained in each bag. If any components are missing, contact Chief Manufacturing at 1-800-582-6480 or 952-582-6480

Table 1: Parts Bag Contents

Item	Description	Qty.
Bracket	Universal Bracket	(2)
Parts Bag A	10-24 X 7/8" Button Head Screw	(4)
	Mounting Button	(4)
	10-24 Nylock Nut	(4)
	Hex Key, 1 1/8"	(1)
Parts Bag B	M8 X 40MM Phillips Pan Head Screw	(4)
	M8 X 50MM Phillips Pan Head Screw	(4)
	M8 X 70MM Phillips Pan Head Screw	(4)
Parts Bag C	M6 X 35MM Phillips Pan Head Screw	(6)
Parts Bag D	M5 X 30MM Phillips Pan Head Screw	(6)
	M5 X 45MM Phillips Pan Head Screw	(6)
Parts Bag E	.680" X .390" X 5/8" Nylon Spacer	(12)
	.740" X .390" X 1" Nylon Spacer	(4)

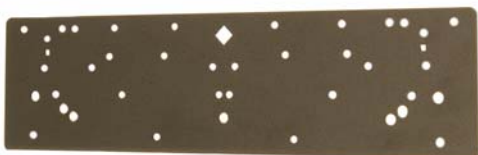
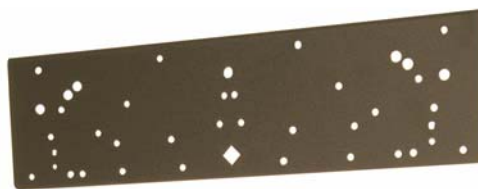

Figure 1. Brackets

SELECT DISPLAY MODEL AND DETERMINE PARTS

These interface brackets are designed to fit a wide variety of display models. Study the following information carefully to select the proper hardware and assembly procedures for your specific Large Flat Panel display model. To determine the correct hardware and procedures, perform the following:

1. Using the chart below, locate your display model.
2. Note and record the group number for your display model.
3. Note and record the parts bags required for your display model.

NOTE: Not all hardware will be used for every installation. Do not discard extra hardware until installation is complete.

4. Using the group number determined in Step 2, proceed to “ATTACH MOUNTING BUTTONS” on page 5 and follow the instructions.

Table 2: Parts Bag Usage

Group	Display Manufacturer	Display Model	Parts Bag
Group 1	Panasonic	TH37PX20UP, TH37PX250UP, TH42PX20UP, TH42PX25UP, TH50PX20UP, TH50PX25UP	A, B & E
Group 2	Panasonic	TH37PA20U, TH37PD25UP, TH42PA20UP, TH42PD25UP	A, B & E
Group 3	Panasonic	37PWD Series, 42PWD Series, 42PD Series, 42PHD Series, 42PW Series, 50PD Series, 50PHD Series, 50PWD Series	A, B & E
Group 4	LG	42” Series	A, D & E
	Mitsubishi	PD4225	
	Tatung	42BLTL, TPD4201S	
	Zenith	42” Displays	
Group 5	Planar	PDP-42HD	A, C & E
	Tatung	P42BSMT	
Group 6	Samsung	42” Displays	A, B & E

ATTACH MOUNTING BUTTONS

Each interface bracket has square holes for attaching mounting buttons (See Figure 2). These holes are arranged in a 24" vertical spacing pattern. When the proper hole pattern is used, the mounting buttons will form a 24" X 24" pattern when installed on your display. The following steps will explain how to attach the mounting buttons.

1. Lay the interface brackets out with the bent lip of each interface bracket down (see Figure 2).
2. Open the parts bag labeled A.
3. Using the mounting buttons and hardware in the parts bag labeled A, attach the mounting buttons in the inside square holes of each interface bracket (see Figure 2 and Figure 3).
4. Using the group number recorded for your display model, proceed to "DETERMINE BRACKET INSTALLATION PROCEDURES" on page 6 and follow the instructions for your display model.

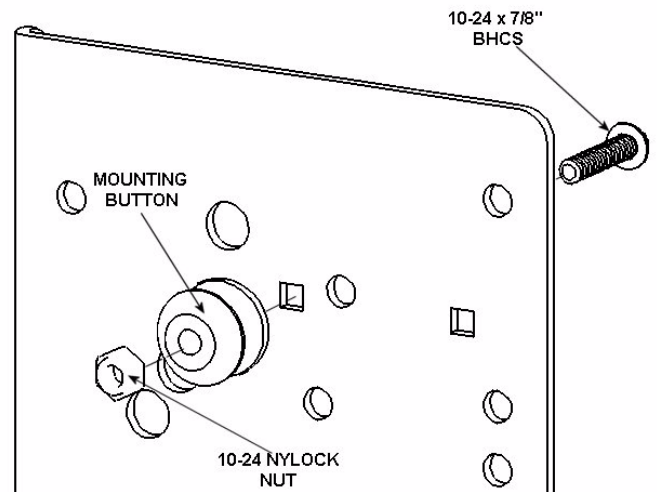

Figure 2. Bracket with Bent Lip Down

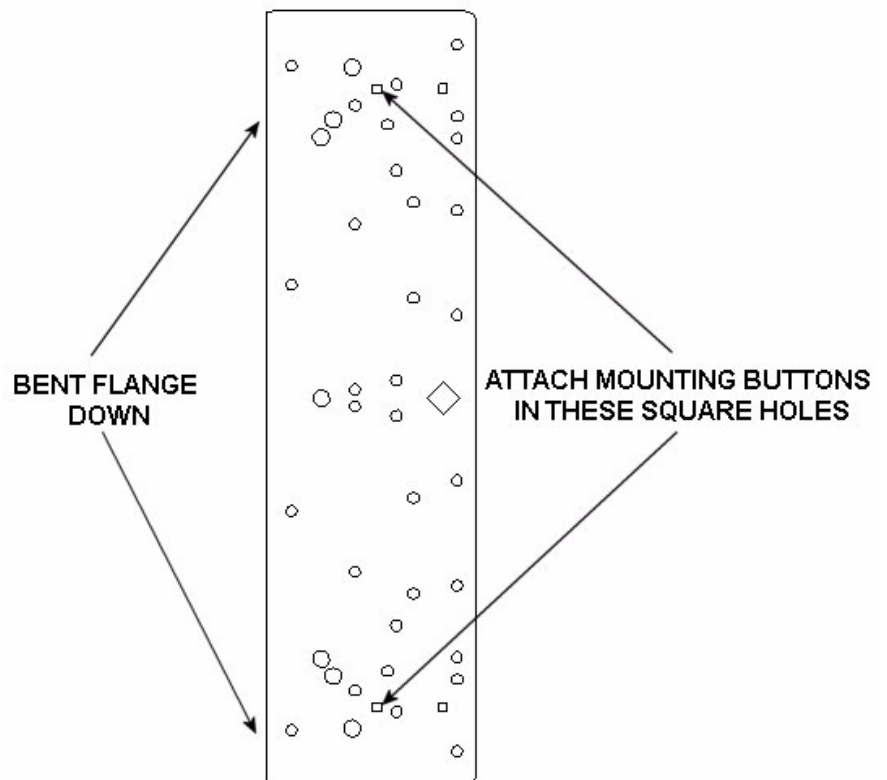

Figure 3. Button Installation

DETERMINE BRACKET INSTALLATION PROCEDURES

Group 1 Installation Procedures

WARNING: You must use proper attaching hardware and installation procedures. Failure to use proper attaching hardware and installation procedures may result in equipment damage or serious personal injury.

Attach Interface Brackets

1. Identify and select the parts bags labeled B and E.
2. Remove the Nylon spacers from the parts bag labeled E.
3. Place four 5/8" and 1" Nylon spacers over the mounting holes on your display (see Figure 4).
4. Place the interface brackets over the Nylon spacers (see Figure 4 and Figure 5).
5. Select the parts bag labeled B.

CAUTION: Overtightening mounting screws may damage your display.

6. Using the hardware in the parts bag labeled B, attach the interface brackets to your display (see Figure 5). Do not overtighten the mounting screws.

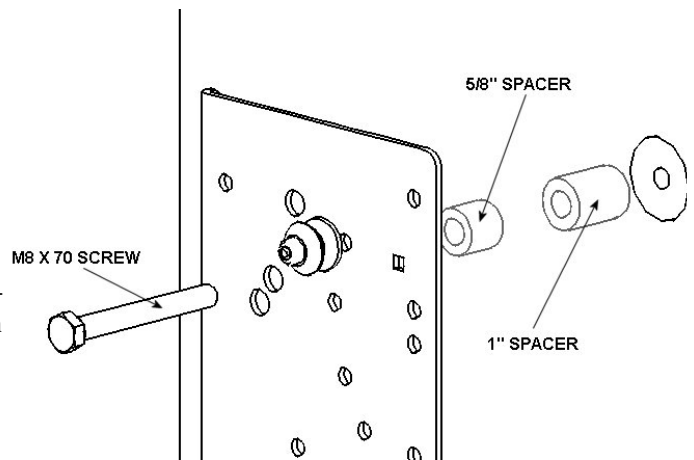

Figure 4. Spacer Installation for Group 1

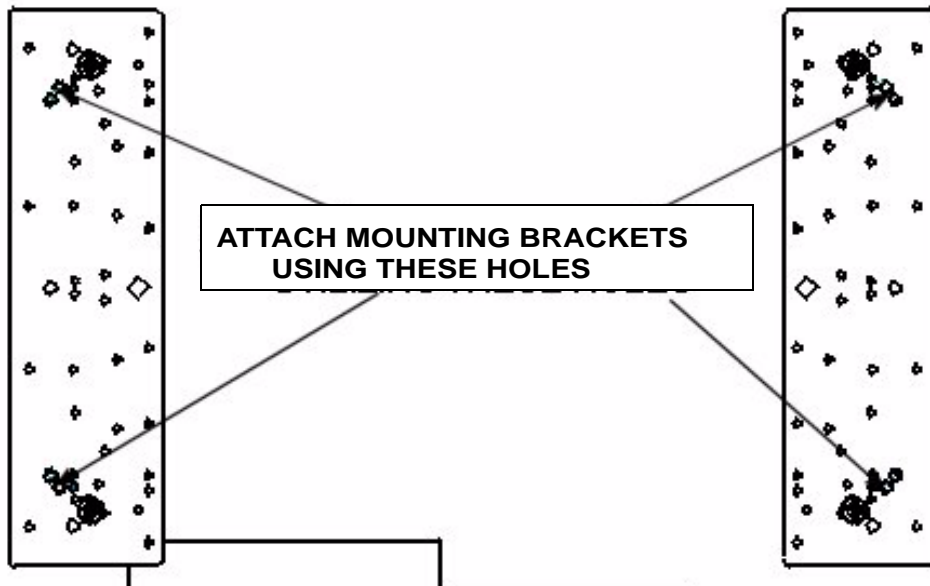

Figure 5. Bracket Attachment for Group 1

Group 2 Installation Procedures

WARNING: You must use proper attaching hardware and installation procedures. Failure to use proper attaching hardware and installation procedures may result in equipment damage or serious personal injury.

Attach Interface Brackets

1. Identify and select parts bags labeled B and E.
2. Remove Nylon spacers from the parts bag labeled E.
3. Place eight 5/8" Nylon spacers over the mounting holes on your display (see Figure 6).
4. Place the interface brackets over the Nylon spacers (see Figure 6 and Figure 7).
5. Select the parts bag labeled B.

CAUTION: Overtightening mounting screws may damage your display.

6. Using the hardware in the parts bag labeled B, attach the interface brackets to your display (see Figure 6 and Figure 7). Do not overtighten the mounting screws.

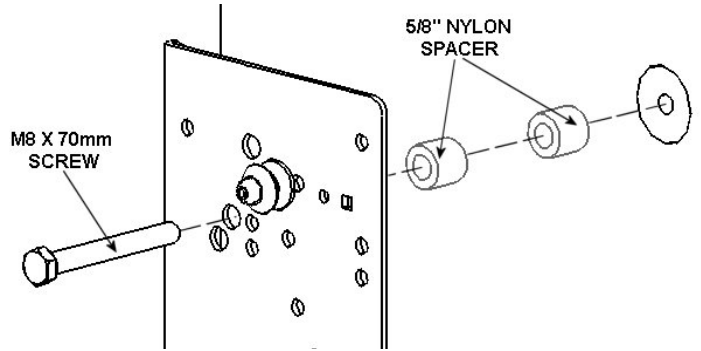

Figure 6. Spacer Installation for Group 2

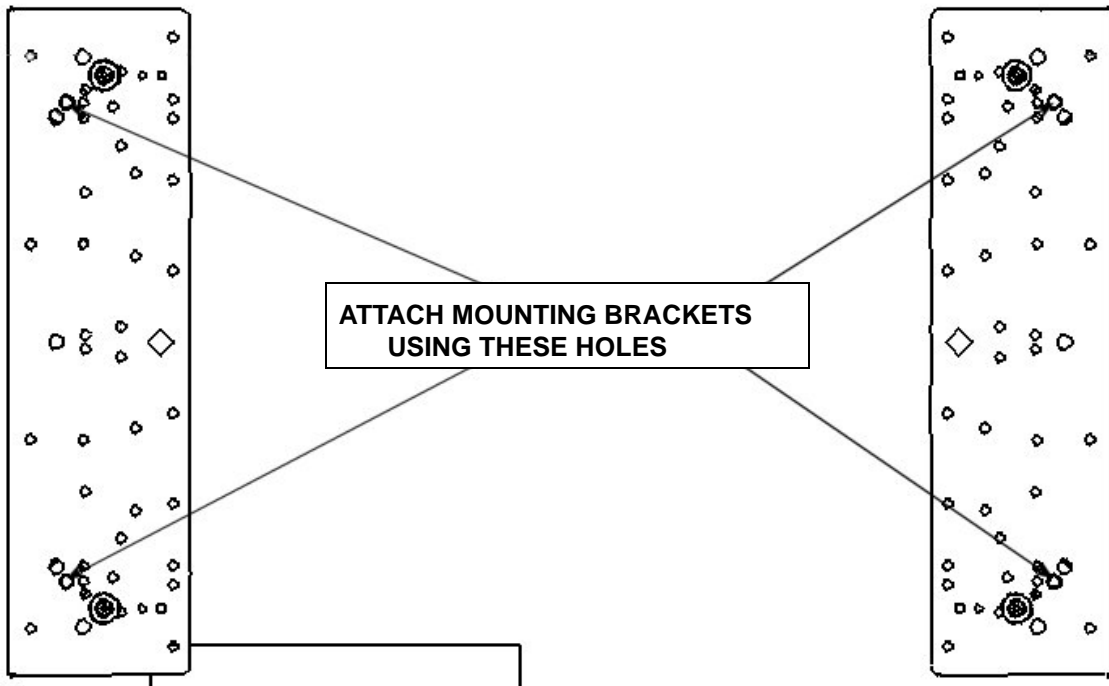

Figure 7. Bracket Attachment for Group 2

Group 3 Installation Procedures

WARNING: You must use proper attaching hardware and installation procedures. Failure to use proper attaching hardware and installation procedure may result in equipment damage or serious personal injury.

Attach Interface Brackets

1. Identify and select the parts bags labeled B and E.
2. Remove the Nylon spacers from the parts bag labeled E.
3. Place four 1" Nylon spacers over the mounting holes on your display.
4. Place the interface brackets over the Nylon spacers (see Figure 8 and Figure 9).
5. Select the parts bag labeled E.

CAUTION: Overtightening mounting screws may damage your display.

6. Using the hardware in the parts bag labeled B, attach the interface brackets to your display using the proper holes in each interface bracket (See Figure 8 and Figure 9). Do not overtighten the mounting screws.

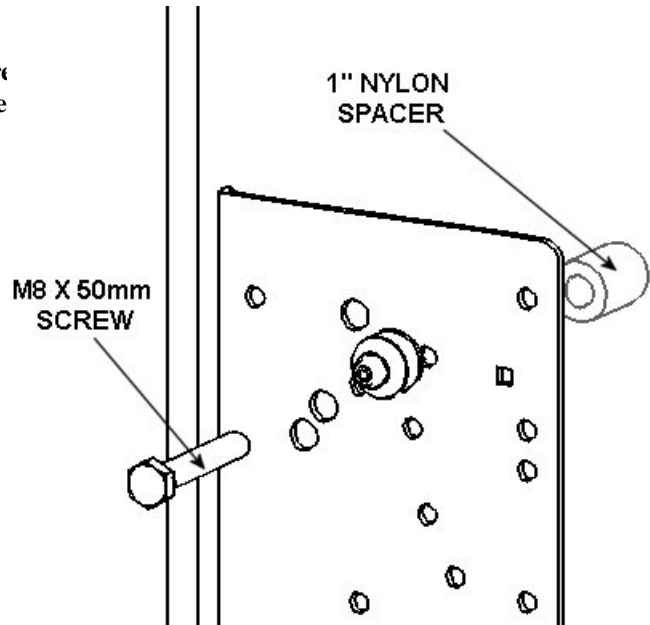

Figure 8. Spacer Installation for Group 3

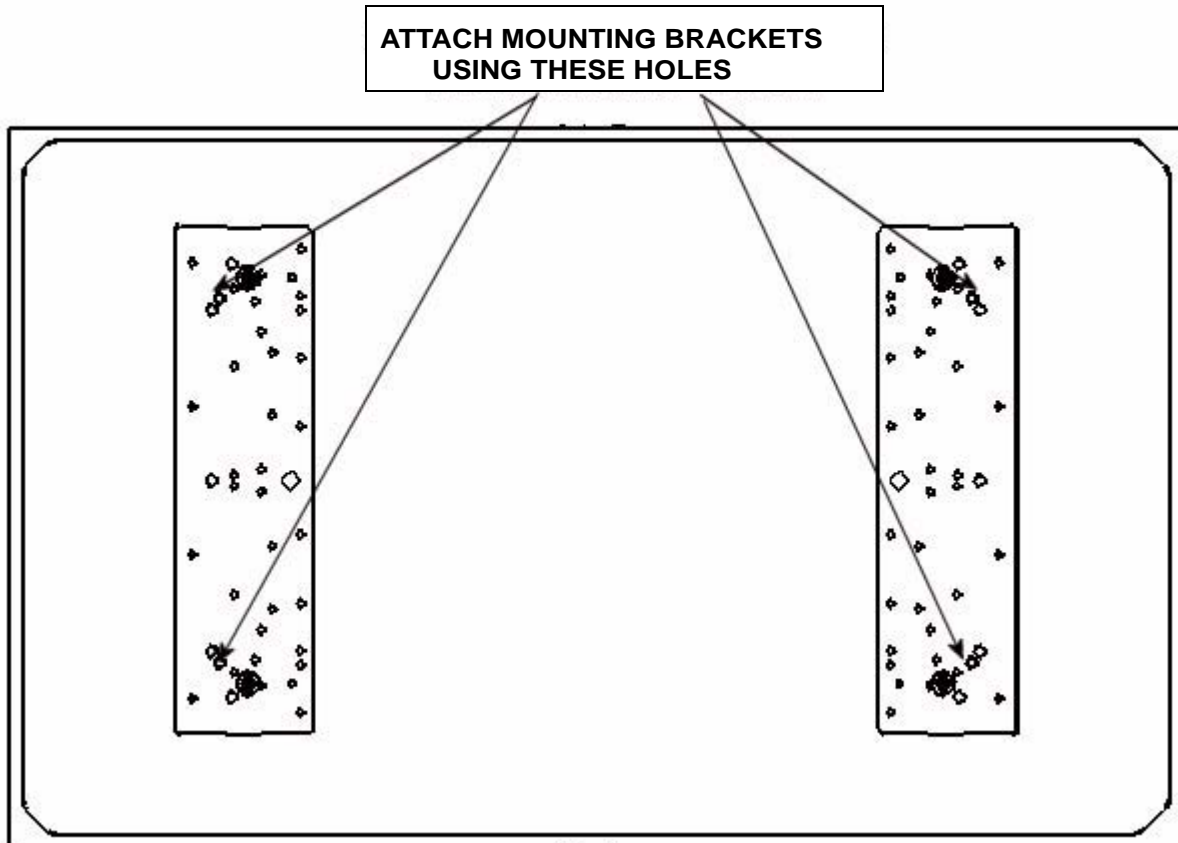

Figure 9. Bracket Attachment for Group 3

Group 4 Installation Procedures

WARNING: You must use proper attaching hardware and installation procedures. Failure to use proper attaching hardware and installation procedures may result in equipment damage or serious personal injury.

Attach Interface Brackets

1. Identify and select the parts bags labeled D and E.
2. Remove the Nylon spacers from the parts bag labeled E.
3. Place four 5/8" Nylon spacers over the mounting holes on your display.
4. If installing a media box, place four additional 5/8" Nylon spacers over the spacers installed in Step 3 (see Figure 11).
5. Place the interface brackets over the Nylon spacers (see Figure 10 and Figure 12).
6. Select the parts bag labeled E.

CAUTION: Overtightening mounting screws may damage your display.

7. Using the hardware in the parts bag labeled D, attach the interface brackets to your display in the proper holes in each interface bracket (See Figure 10 and Figure 12). Do not overtighten the mounting screws.

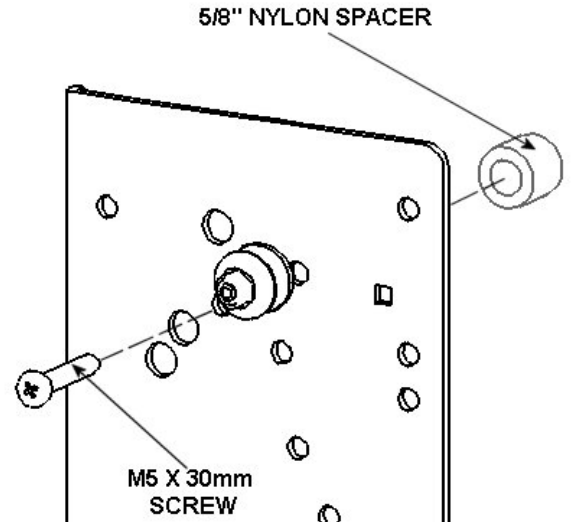

Figure 10. Spacer Installation for Group 4

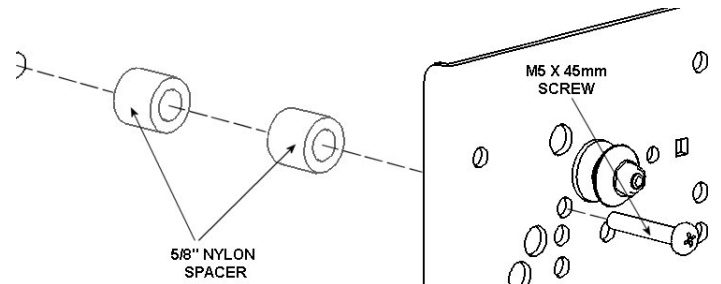

Figure 11. Installation with Media Box for Group 4

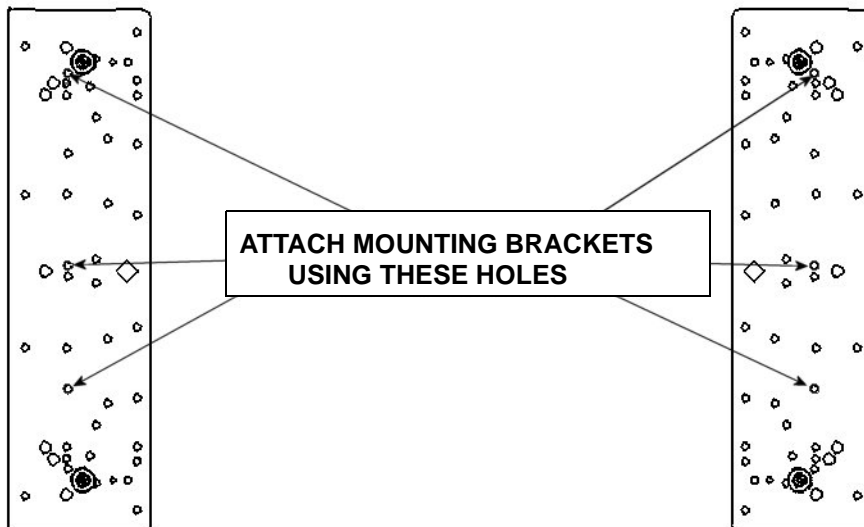

Figure 12. Bracket Attachment for Group 4

Group 5 Installation Procedures

WARNING: You must use proper attaching hardware and installation procedures. Failure to use proper attaching hardware and installation procedures may result in equipment damage or serious personal injury.

Attach Interface Brackets

1. Identify and select the parts bags labeled C and E.
2. Remove the Nylon spacers from the parts bag labeled E.
3. Place four 5/8" Nylon spacers over the mounting holes on your display.
4. Place the interface brackets over the Nylon spacers (see Figure 13 and Figure 14).
5. Select the parts bag labeled E.

CAUTION: Overtightening mounting screws may damage your display.

6. Using the hardware in the parts bag labeled C, attach the interface brackets to your display in the proper holes in each interface bracket (See Figure 13 and Figure 14). Do not overtighten the mounting screws.

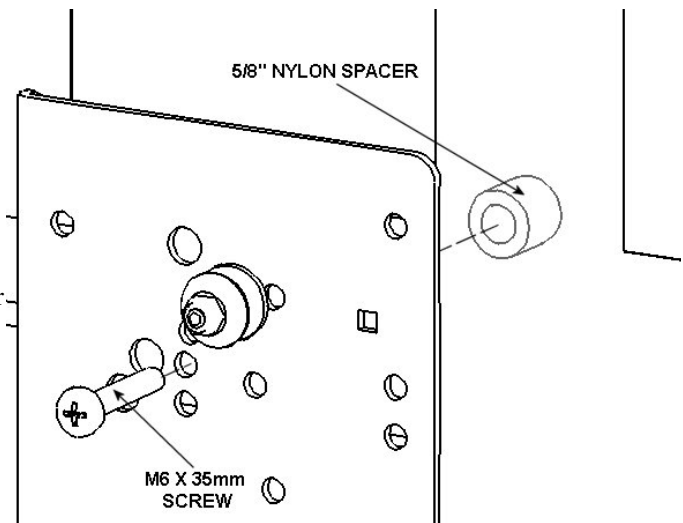

Figure 13. Spacer Installation for Group 5

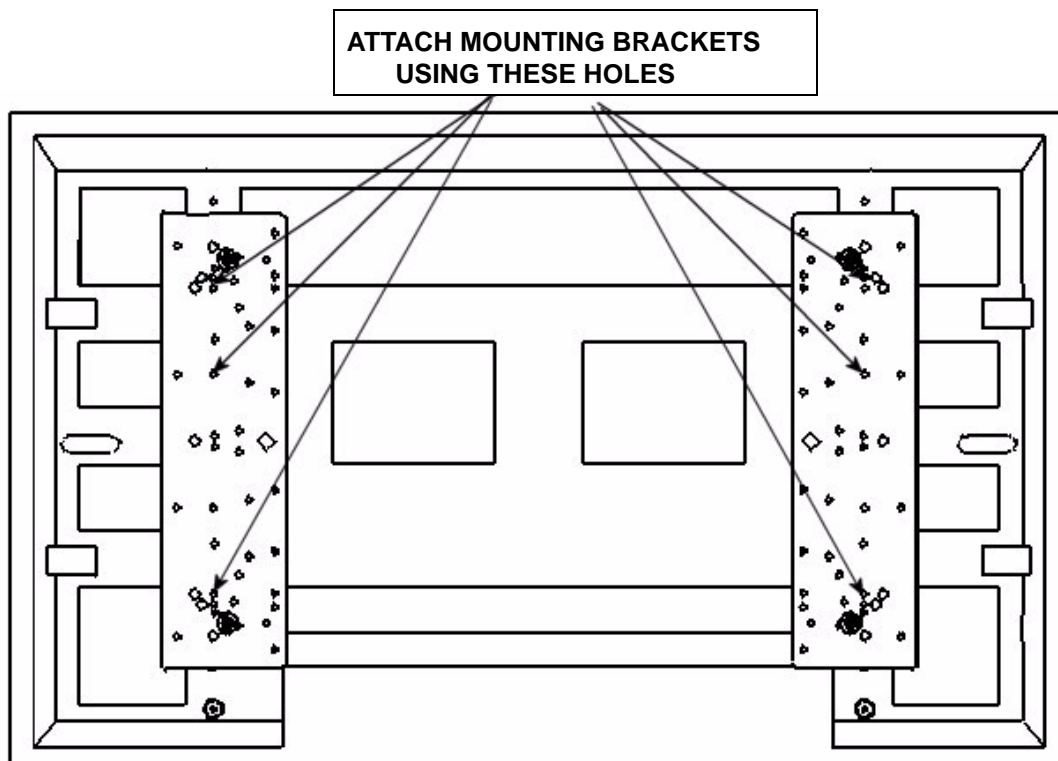

Figure 14. Bracket Attachment for Group 5

Group 6 Installation Procedures

WARNING: You must use proper attaching hardware and installation procedures. Failure to use proper attaching hardware and installation procedures may result in equipment damage or serious personal injury.

Attach Interface Brackets

1. Identify and select the parts bags labeled B and E.
2. Remove the Nylon spacers from the parts bag labeled E.
3. Place four 1" Nylon spacers over the mounting holes on your display.
4. Place the interface brackets over the Nylon spacers (see Figure 15 and Figure 16).
5. Select the parts bag labeled E.

CAUTION: Overtightening mounting screws may damage your display.

6. Using the hardware in the parts bag labeled B, attach the interface brackets to your display in the proper holes in each interface bracket (See Figure 15 and Figure 16). Do not overtighten the mounting screws.

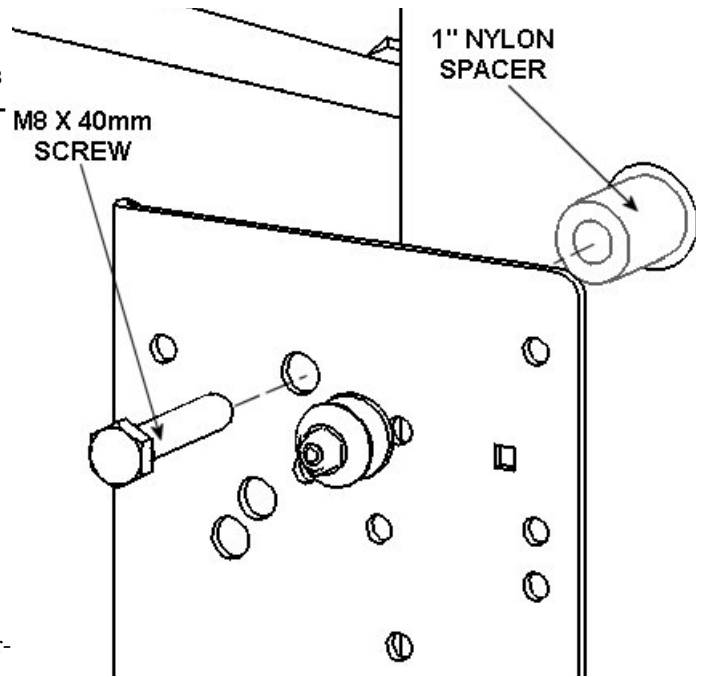

Figure 15. Spacer Installation for Group 6

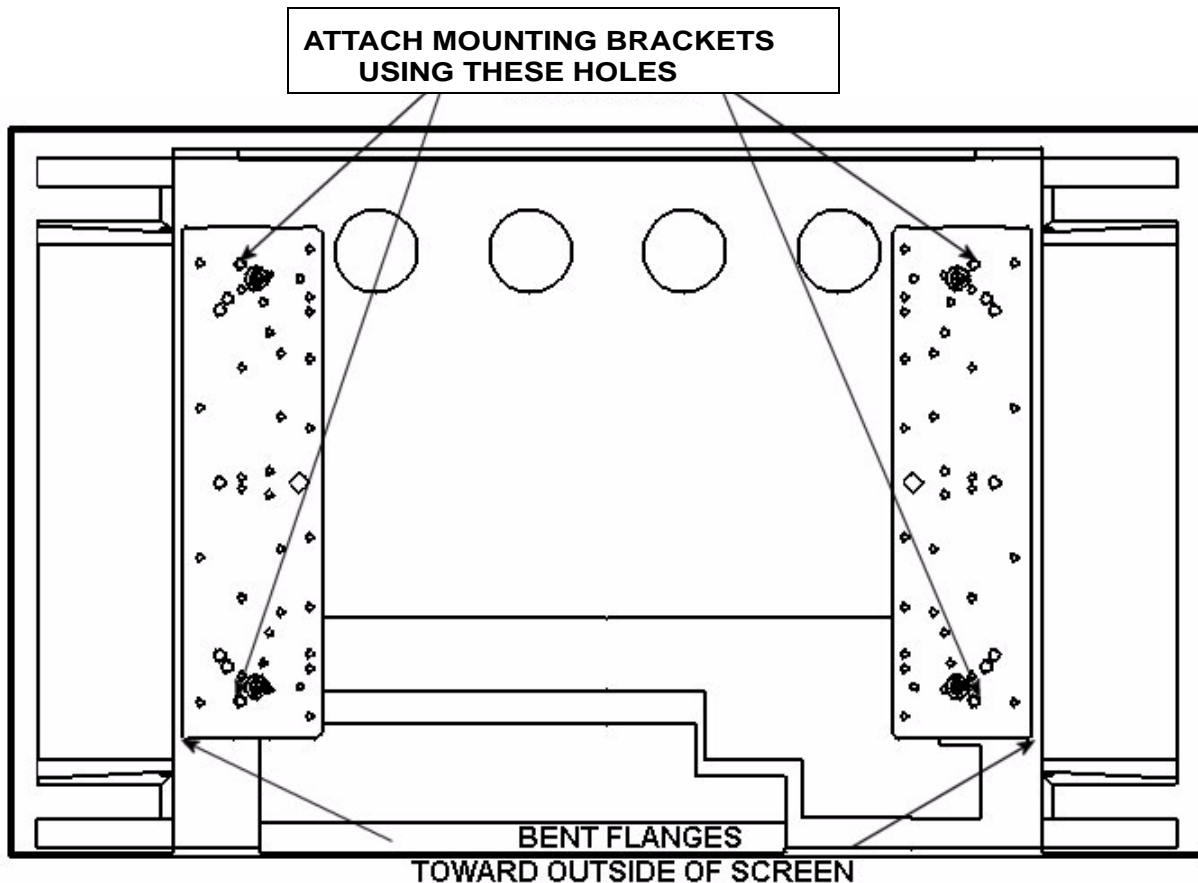

Figure 16. Bracket Attachment for Group 6

