

INSTALLATION INSTRUCTIONS

Small Flat Panel Bracket – Floor Stand (PAC-170)

The PAC-170 Floor Stand assembly is compatible with small flat panels and other products and accessories offered by Chief.

PARTS

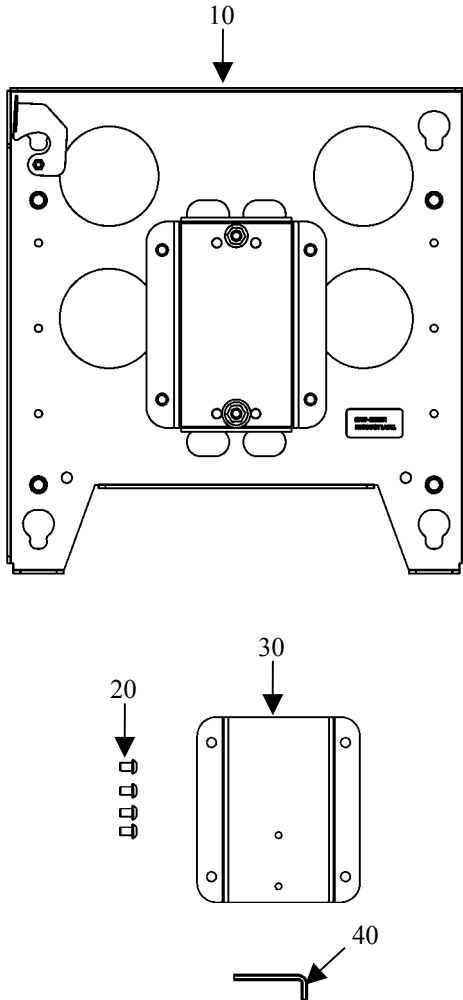

Figure 1. Parts

PARTS LIST

Unpack the shipping carton and check for the contents listed in Table 1 and shown in Figure 1.

Table 1. Parts List

REF	DESCRIPTION	QTY
10	FRONT BRACKET, floor stand (with attached mounting plate)	1
20	SCREW, button head cap, 5/16-18 x 1/2"	4
30	BACK BRACKET, floor stand	1
40	ALLEN KEY, 3/16"	1

TOOLS REQUIRED FOR INSTALLATION

- 3/16" Allen Key (provided)

NOTE: Other tools may be required depending on your method of installation.

INSTALLATION

To install the PAC-170 bracket assembly, do the following:

Attach PAC-170 to Floor Stand

NOTE: Make sure that mounting plate faces toward the front of the floor stand before attaching the PAC-170 to the floor stand.

1. Attach front bracket (10) and back bracket (30) to the floor stand post (see Figure 2) using four 5/16-18 x 1/2" button head cap screws (20).
2. Adjust the PAC-170 to the desired height on the floor stand.
3. Tighten the screws.

Mount the Display

1. Make sure power is not supplied (turned off) to the display and the locking device is in the unlocked (down) position (see Figure 4) before attempting to mount the display.
2. Following the instructions for mounting the PSB interface bracket of your specific plasma display panel, install the mounting bracket on your plasma display panel.
3. With an assistant, slide the display down over the mounting plate on the PAC-170. Make sure buttons of PSB interface bracket fully engage all teardrop slots on the mounting plate.
4. Secure the mounting bracket to the PAC-170 by completely engaging the locking device (see Figure 4).

WARNING: Make sure the locking device securing the display is completely engaged at all times except when removing or installing the display.

NOTE: A padlock may be used on the locking device for increased security.

5. Connect and secure power/audio/video cables (not shown).

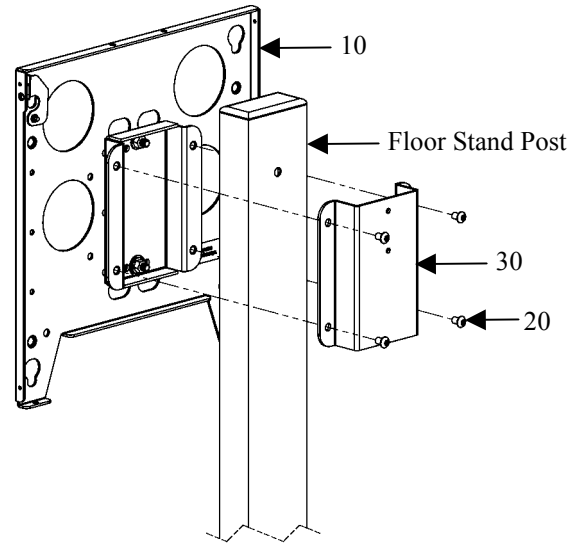

Figure 2. Attach PAC-170 to Floor Stand

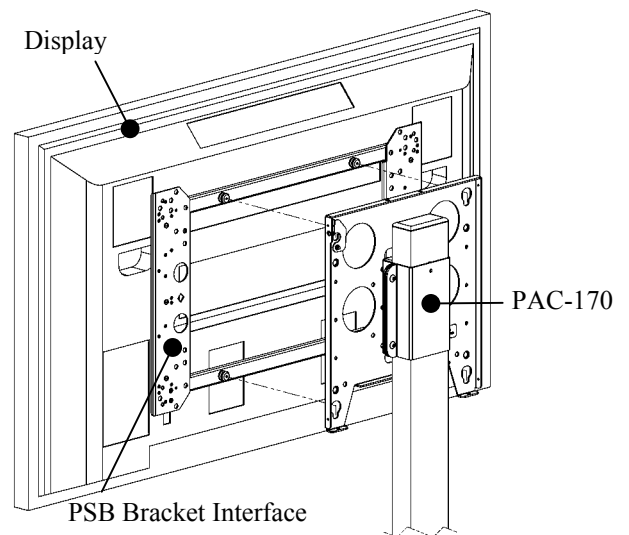

Figure 3. Mount the Display

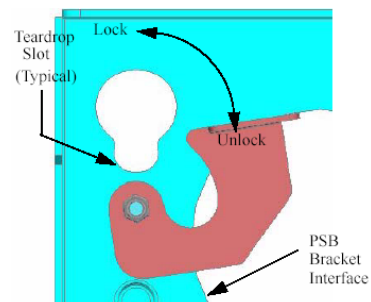

Figure 4. Locking Device