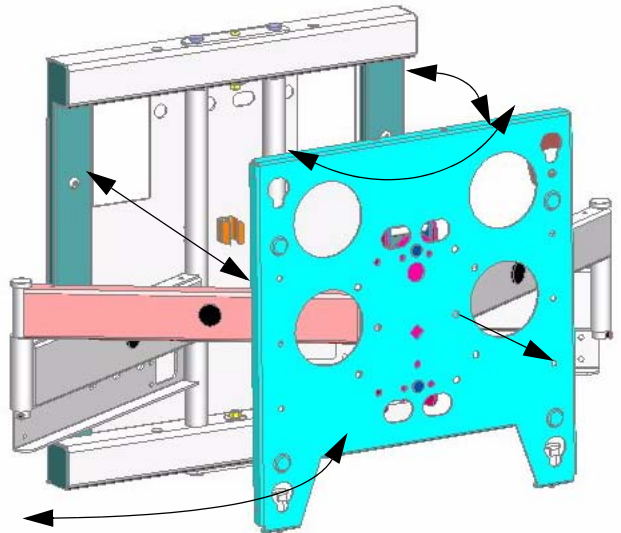

INSTALLATION INSTRUCTIONS

Plasma Dual Swing-Out (PDS Series) Wall Mount^{UL}

The PDS wall mount is a rugged, versatile, and installer-friendly solution to unique display mounting requirements. In addition to providing lateral movement, tilt and rotational capability, the PDS allows you to mount your display landscape or portrait.

The dual arm design provides the exceptional strength required to support heavy plasma screens (up to 61"). You can pull your display out more than 33" from the wall, pivot it up to 90 degrees left or right of center, adjust the pitch infinitely between approximately 5 degrees up and 15 degrees down and allows some rotational adjustment.

With the brackets attached to the display and the PDS securely mounted on a wall, simply hang your plasma like a picture and lock the display in place using the convenient flag. Two outlet holes in the mounting plate and cable management along each arm are provided.



BEFORE YOU BEGIN

- **Caution:** To prevent damage to the PDS, which could affect or void the Factory warranty, and to the equipment that will be attached to it, thoroughly study all instructions and illustrations before you begin the installation. Pay particular attention to the "Important Warnings and Precautions" on Page 2.
- The maximum weight to be installed on the PDS wall mount is **150 pounds** (68.36 Kg).
- The PDS wall mount is designed to be installed using wall studs or supporting framework. The wall to which the PDS wall mount is anchored must be capable of supporting **four times** the total weight of the mount and all attached equipment.
- If you have any questions about this installation, contact Chief Manufacturing at 1-800-582-6480.



IMPORTANT WARNINGS AND PRECAUTIONS!

WARNING: A **WARNING** alerts you to the possibility of serious injury or death if you do not follow the instructions.

CAUTION: A **CAUTION** alerts you to the possibility of damage or destruction of equipment if you do not follow the corresponding instructions.

- **WARNING:** **Improper installation can result in serious personal injury! Make sure that the structural members can support a redundant weight factor *five times* the total weight of the equipment: if not, reinforce the structure before installing the PDS.**
- **WARNING:** **Be aware also of the potential for personal injury or damage to the unit if it is not adequately mounted.**
- **WARNING:** **The installer is responsible for verifying that the wall to which the PDS is anchored will safely support the combined load of all attached components or other equipment.**
- **WARNING:** **The weight of the display placed on the PDS must not exceed 150 lbs. (68.04 kg), the maximum load capacity of the PDS.**
- **WARNING:** **Watch for pinch points. Do not put your fingers between movable parts.**
- **WARNING:** **Make sure the mount and brackets are correctly oriented.**
- **WARNING:** **Make sure the flag securing the display is completely lowered at all times *except* when removing or installing the display.**
- **CAUTION:** Check the unit for shipping damage before you begin the installation.

NOTE: Hardware for attaching this unit to the wall is not supplied.

TOOLS REQUIRED FOR INSTALLATION

- Electric drill and bit set
- Socket set with extension and open wrenches

NOTE: Other tools may be required depending on the method of installing the lift in the ceiling.

INSPECT THE UNIT BEFORE INSTALLING

WARNING: Watch for pinch points. Do not put your fingers between movable parts.

1. Carefully inspect the PDS for shipping damage. If any damage is apparent, call your carrier claims agent and do not continue with the installation until the carrier has reviewed the damage.

NOTE: Read all instructions before starting installation.

2. Lay out components to ensure you have all the required parts before proceeding (see PDS dimensional drawing on page 4).

CONTENTS

| | |
|--|---|
| TOOLS REQUIRED FOR INSTALLATION | 3 |
| INSPECT THE UNIT BEFORE INSTALLING | 3 |
| DIMENSIONAL DRAWING | 4 |
| PDS INSTALLATION | 5 |
| MOUNT THE DISPLAY | 6 |
| CABLE MANAGEMENT | 6 |
| ADJUSTMENTS | 7 |
| REMOVE THE DISPLAY | 8 |

DIMENSIONAL DRAWING

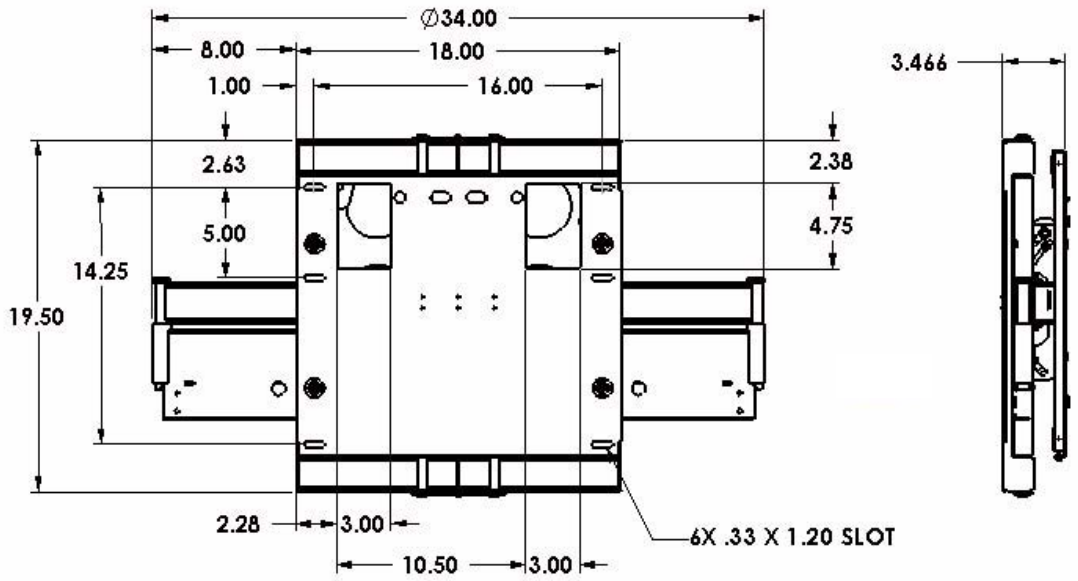
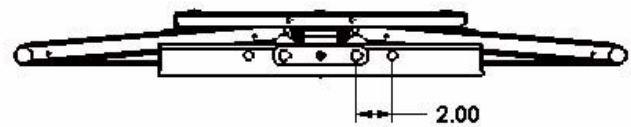
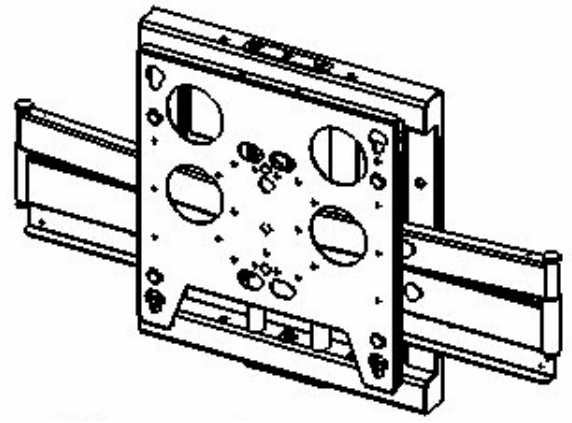
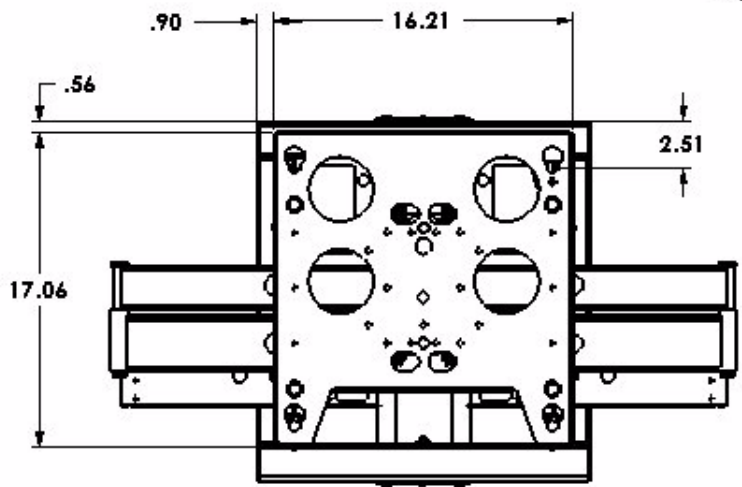

PDS INSTALLATION

WARNING: The PDS must be installed with correct end, indicated by “Mount This Side Up”, on top.

WARNING: It is the responsibility of the installer to verify that the wall to which the PDS is anchored will safely support the combined load of all attached components and equipment.

Install the PDS as follows:

1. Determine the exact mounting location prior to installation, considering the unit’s total swing arm radius, and draw a level line to indicate the desired height of the top of the mounting plate.
2. Remove four screws (two each side) and two cover plates (one each side. See Figure 1).
3. Drill two pilot holes 2 1/2” below the line drawn in Step 1 measuring 16” apart.

NOTE: Notice the wall plate has 2 nominal holes (2”X4”) to accommodate two duplex wall outlets.

WARNING: Improper installation can result in serious personal injury! Make sure that the structural members can support a redundant weight factor *five times* the total weight of the equipment: if not, reinforce the structure before installing the PDS.

4. With the PDS correctly oriented and level, secure the PDS to the wall using two fasteners (not included) in the top mounting holes (see Figure 2). Fasteners must be driven into the supporting wall studs or other supporting framework.
5. Using the mounting plate as a template, drill pilot holes in the remaining four mounting holes and, if using one or both electrical box cutouts, trace cutout location(s).
6. Secure the PDS to the wall using all six fasteners (not included). Fasteners must be driven into the supporting wall studs or other supporting framework.
7. Check mount to insure it is level and adjust to level if necessary.
8. Install two cover plates and secure using four screws (see Figure 1).

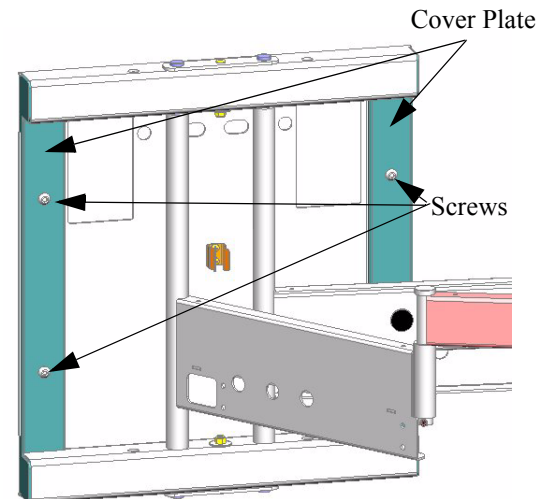

Figure 1. Cover Plate Removal

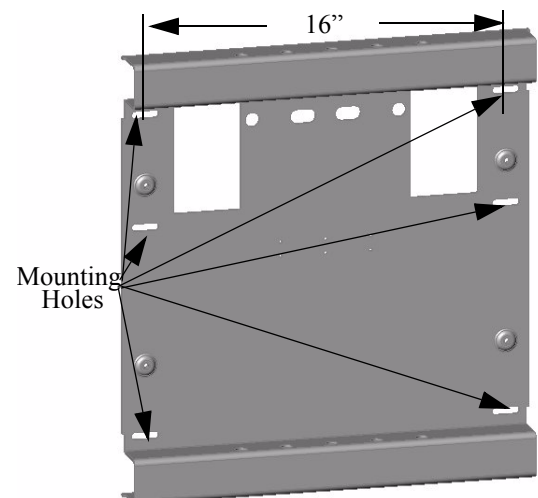

Figure 2. Mounting Holes

MOUNT THE DISPLAY

1. Make sure no power is supplied to the display and the locking device is in the unlocked (down) position (see Figure 3) before attempting to mount the display.

NOTE: Skip step 2 for the Sony PFM Series plasmas. These models do not require a mounting bracket.

2. Following the instructions for mounting the hanging bracket of your specific plasma display panel, install the mounting bracket on your plasma display panel.

WARNING: Watch for pinch points. Do not put your fingers between movable parts.

3. Using two people, slide the display down over the PDS. Make sure the slots of the mounting bracket fully engage all hooks of the PDS.
4. Secure the mounting bracket to the PDS by completely engaging the locking device (see Figure 3).

WARNING: Make sure the locking device securing the display is completely engaged at all times except when removing or installing the display. The locking device must be completely engaged during installation/removal of cables when the display is mounted.

5. Connect and secure power/audio/video cables, making sure to leave sufficient slack to allow for movement of the swing arms.

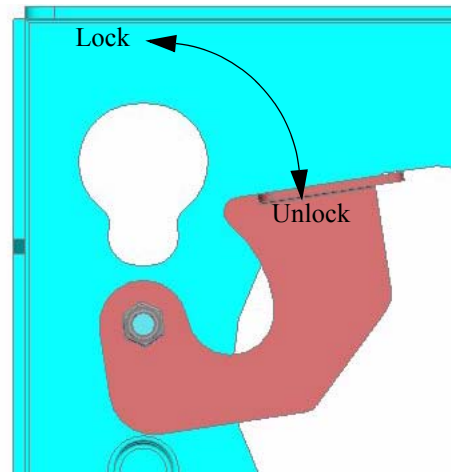

Figure 3. Locking Device

CABLE MANAGEMENT

WARNING: Make sure your cables do not run through a pinch point.

1. Route power/audio/video cables through the access hole (see Figure 4), allowing sufficient slack in cables for extension and avoiding pinch points.
2. Route power/audio/video cables along arm, using tiewraps to secure cables to arm, and through access hole.
3. Route power/audio/video cables through the cutout in the mounting plate, allowing sufficient slack in cables for extension.

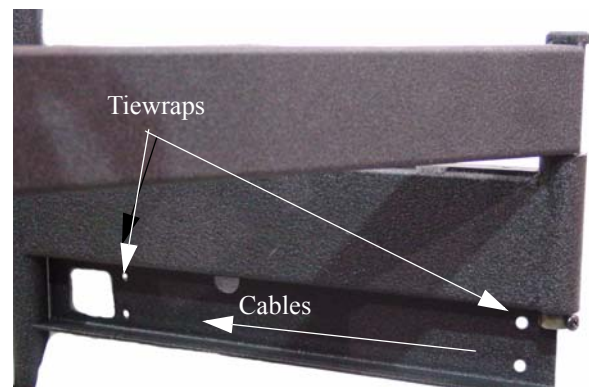

Figure 4. Cord Management

ADJUSTMENTS

Vertical Tilt Tension Adjustment

1. Using 5/32" Allen wrench (provided), slightly tighten or loosen two screws, one on each side, equally (see Figure 5).
2. With display mounted, check for desired vertical tilt tension.
3. Repeat Step 1 and Step 2 until desired vertical tilt tension is obtained.



Figure 5. Vertical Tilt

Lateral Tilt Tension Adjustment

CAUTION: Overtightening lateral adjustment will cause excessive wear and may distort adjustment components.

1. Using a 3/8" wrench (not provided), slightly tighten or loosen lateral tilt tension adjustment nut (see Figure 6).
2. Mount the display and check for desired tilt tension.
3. Repeat Steps 1 and 2 until desired tilt tension is obtained.

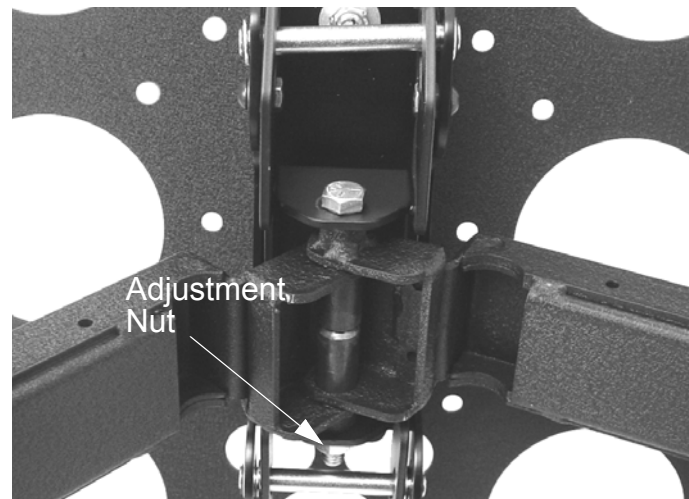

Figure 6. Lateral Tilt

Rotational Tilt Tension Adjustment

1. If necessary, loosen or tighten bottom rotational tilt tension adjustment nut (see Figure 7).
2. Mount the display and check for desired rotational tilt tension.
3. Repeat Steps 1 and 2 until desired rotational tilt tension is obtained.

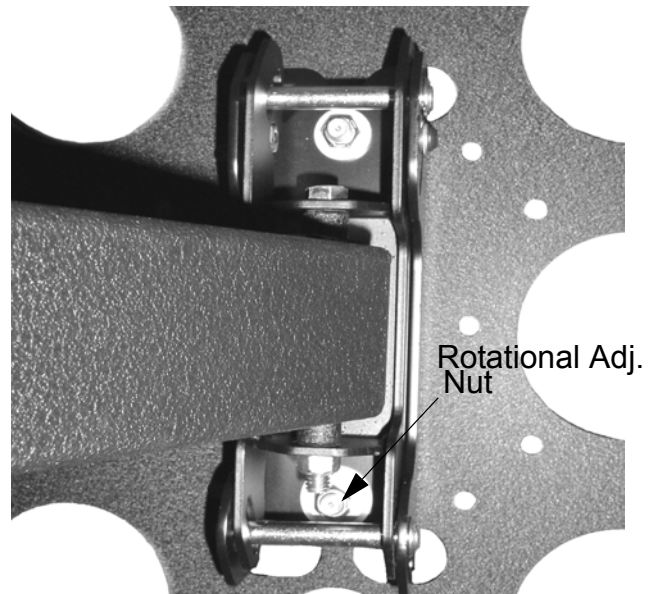

Figure 7. Rotational Adjustment

Swing Arm Location Adjustment

1. Remove the display from the mount.
2. Remove two screws securing retainer clip and remove retainer clip (see Figure 8).

WARNING: The next step may release the arm assemblies from the mount. The arms and plate may fall if you are not careful.

3. Remove two bolts (one top and one bottom) securing retaining pin assemblies (one top and one bottom).

WARNING: The next step will release the arm assemblies from the mount. The arms and plate may fall if you are not careful.

4. Remove two retaining pin assemblies.
5. Move arm assemblies to desired location.
6. Install retaining pin assemblies (one top and one bottom) and secure using two bolts (one top and one bottom).
7. Install retainer clip between swing arm assemblies and secure retainer clip using two screws.

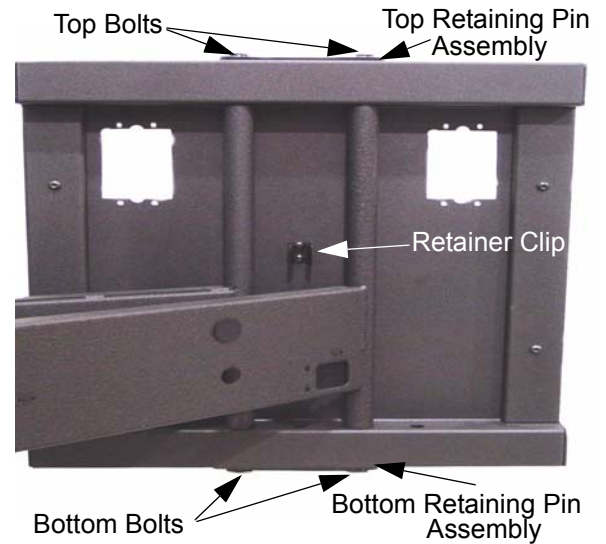

Figure 8. Swing Arm Adjustment

REMOVE THE DISPLAY

1. Disconnect power/audio/video cables.
2. Release the locking device (see Figure 3).
3. Using two people, lift the display up from the PDS.