



INSTALLATION INSTRUCTIONS

PSB-2082

PLASMA DISPLAY MOUNTING BRACKET

Prior to assembly, unpack carton completely and verify contents.

If you are missing any of the following components, please contact Customer Service at 1-800/582-6480

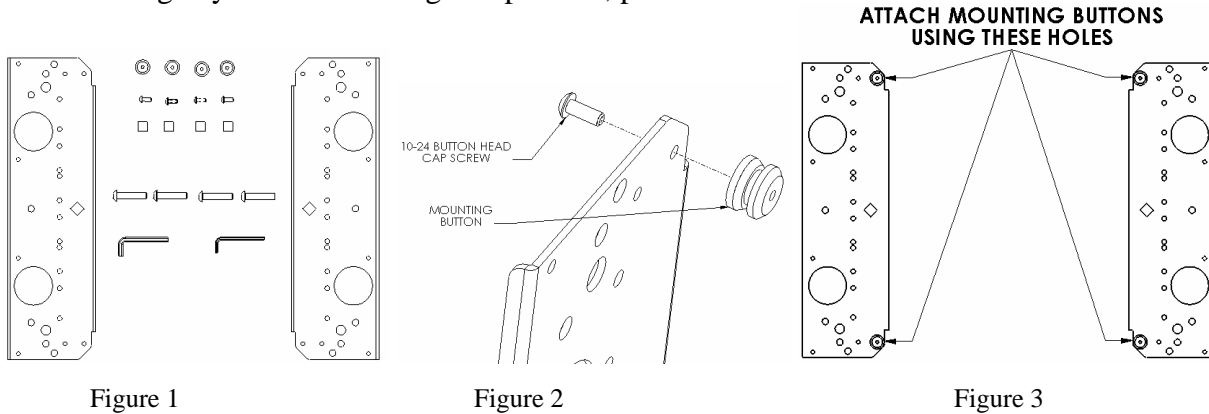

- | | |
|--|--|
| (2) Plasma Side Bracket | (6) 1.1875 Steel Spacer |
| (4) Mounting Buttons-Tapped 10-24 | (4) 10-24 x 1/2" Button Head Cap Screw |
| (6) M8-1.25 x 50mm Button Head Cap Screw | (1) 1/8" Allen Key |
| (1) 5mm Allen Key | |

BEFORE PROCEEDING, READ INSTALLATION INSTRUCTIONS COMPLETELY

CAUTION! PLASMA DISPLAYS ARE EXTREMELY FRAGILE.

- Using a 10-24 button head cap screw inserted from back side of bracket through holes, secure mounting button, with chamfered hole of mounting button (larger surface) facing bracket, to bracket (four places) (see Figure 2 & Figure 3).
- Place Nylon spacers on mounting holes and align hole pattern on brackets with pattern on back of display (see Figure 4 & Figure 5). Attach bracket using the M8 screws.
- With the aid of another person, lift the display up to the Chief Mount, aligning buttons of mounting brackets with slots in the Chief Mount.
- Lower safety catch on the Chief Mount to secure the display, making sure latch is completely engaged.

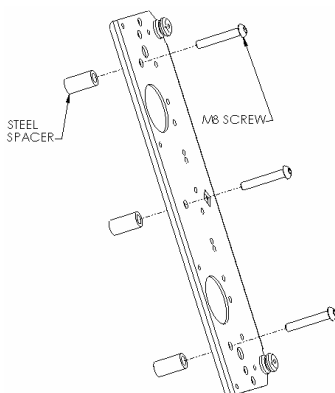

Figure 4

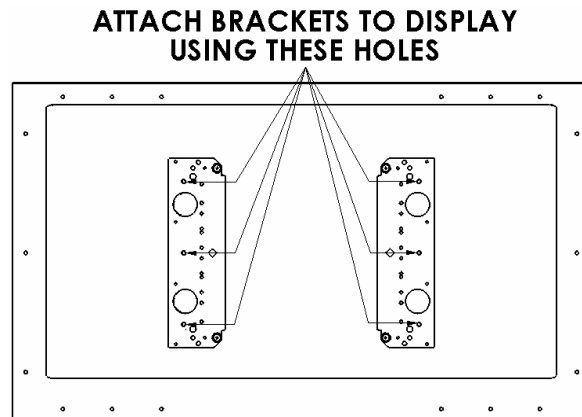

Figure 5