INSTALLATION INSTRUCTIONS

PSB-2175

FLAT PANNEL DISPLAY MOUNTING BRACKET

Prior to assembly, unpack carton completely and verify contents.

If you are missing any of the following components, please contact Customer Service at 1-800/582-6480

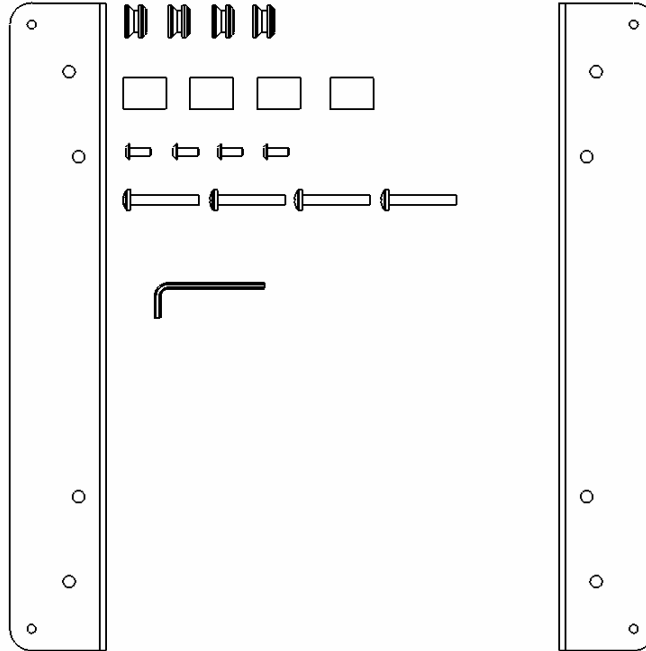

Figure 1

(2) Side Bracket

(4) 10-24 x .5 Button Head Cap Screw

(4) .74 od x .39 id x 1.0 L Nylon Spacer

(4) Mounting Button – Tapped

(4) M6 x 40 Phillips Head Screws

(1) 1/8 Allen Key

BEFORE PROCEEDING, READ INSTALLATION INSTRUCTIONS COMPLETELY

CAUTION! **DISPLAYS ARE EXTREMELY FRAGILE.**

WARNING!

ALL COMPONENTS MUST BE SECURELY FASTENED TO A STRUCTURAL MEMBER CAPABLE OF SUPPORTING 4 TIMES THE COMBINED WEIGHT OF ALL COMPONENTS PLUS THE EQUIPMENT BEING MOUNTED. IF IT CANNOT SUPPORT THIS WEIGHT, THE STRUCTURE MUST BE REINFORCED.

THE MAXIMUM WEIGHT TO BE INSTALLED ON THE MOUNT IS 200 POUNDS (90.78 KG).



CHIEF MANUFACTURING INC.
1-800-582-6480 952-894-6280 FAX 952-894-6918
8401 EAGLE CREEK PKWY, STE. 700
SAVAGE, MINNESOTA 55378 USA

8804-000351 Rev01
2007 Chief Manufacturing
www.chiefmfg.com
07/07

- Using a 10-24 button head cap screw inserted from back side of bracket, secure mounting button, with chamfered hole of mounting button (larger surface) facing bracket, to top and bottom brackets (four places) (see Figure 2 & Figure 3).

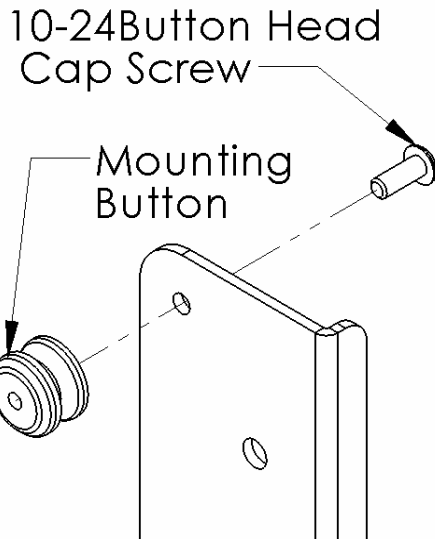

Figure 2

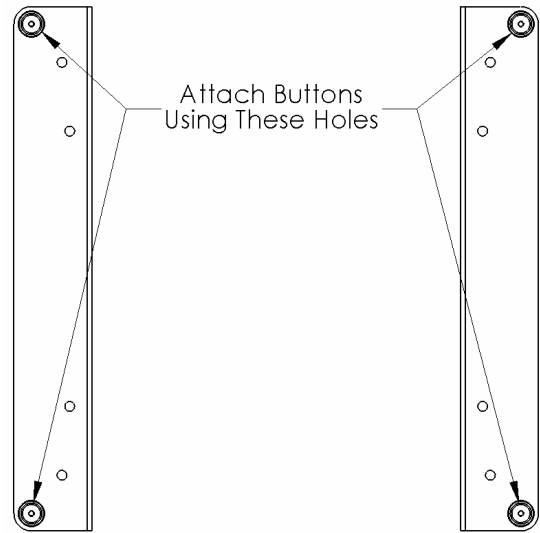

Figure 3

- Place Nylon spacers over mounting holes on back of screen. Attach mounting brackets to display using the M6 screws (see Figure 4 & Figure 5)
- With the aid of another person, lift your display up to the Chief Mount, aligning buttons of mounting brackets with slots in the Chief Mount.
- Lower safety latch on the Chief Mount to secure your display, making sure latch is completely engaged.

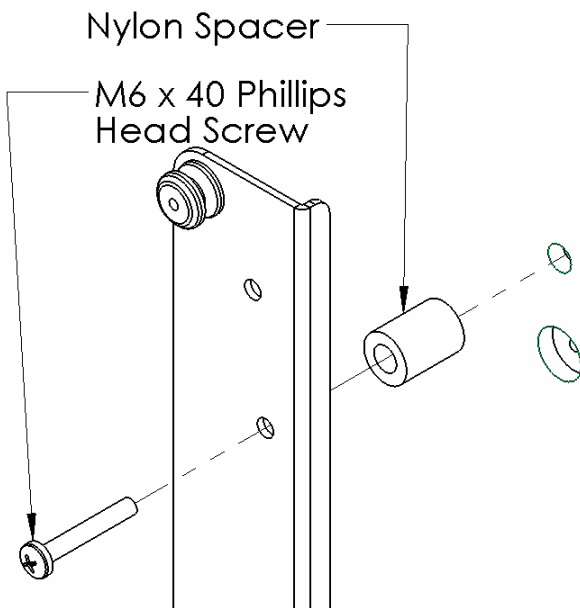

Figure 4

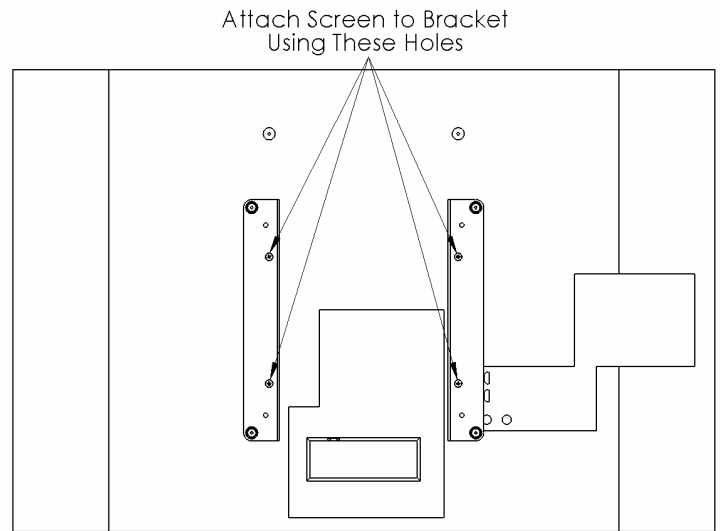

Figure 5