

# INSTALLATION INSTRUCTIONS

## PSB-2530

### PLASMA DISPLAY MOUNTING BRACKET

Prior to assembly, unpack carton completely and verify contents.

If you are missing any of the following components, please contact Customer Service at 1-800/582-6480

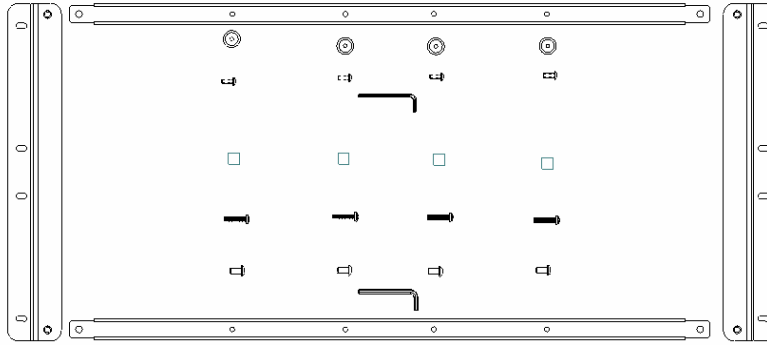

Figure 1

- (2) LCD Interface Side Bracket
- (4) M5-.8 x 25 mm Phillips Head Cap Screw
- (4) 10-24 x 1/2" Button Head Cap Screw
- (4) .50 x .194 x .50 Nylon Spacer
- (1) 1/8" Hex Key

- (2) LCD Interface Center Bracket
- (4) 1/4-20 x 1/2" Button Head Cap Screw
- (4) Mounting Button
- (1) 5/32" Allen Key

BEFORE PROCEEDING, READ INSTALLATION INSTRUCTIONS COMPLETELY

## CAUTION!

**PLASMA DISPLAYS ARE EXTREMELY FRAGILE.**

## WARNING!

**ALL COMPONENTS MUST BE SECURELY FASTENED TO A STRUCTURAL MEMBER CAPABLE OF SUPPORTING 4 TIMES THE COMBINED WEIGHT OF ALL COMPONENTS PLUS THE EQUIPMENT BEING MOUNTED. IF IT CANNOT SUPPORT THIS WEIGHT, THE STRUCTURE MUST BE REINFORCED.**

**THE MAXIMUM WEIGHT TO BE INSTALLED ON THE MOUNT IS 175 POUNDS (79.38 KG).**

1. Using a 10-24 button head cap screw inserted from back side of bracket, secure mounting button, with chamfered hole of mounting button (larger surface) facing bracket, to bracket (four places) (see Figure 2 & Figure 3).



**CHIEF MANUFACTURING INC.**  
1-800-582-6480 952-894-6280 FAX 952-894-6918  
8401 EAGLE CREEK PKWY, STE. 700  
SAVAGE, MINNESOTA 55378 USA

8804-000179 RevC  
2004 Chief Manufacturing  
[www.chiefmfg.com](http://www.chiefmfg.com)  
08/04

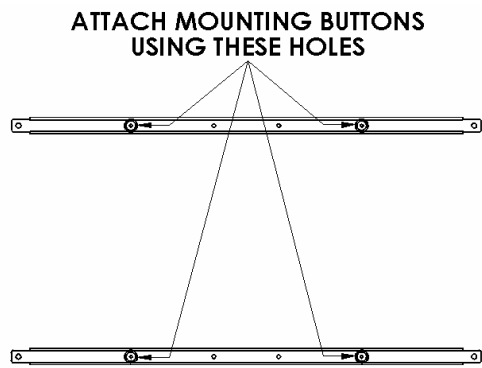

Figure 2

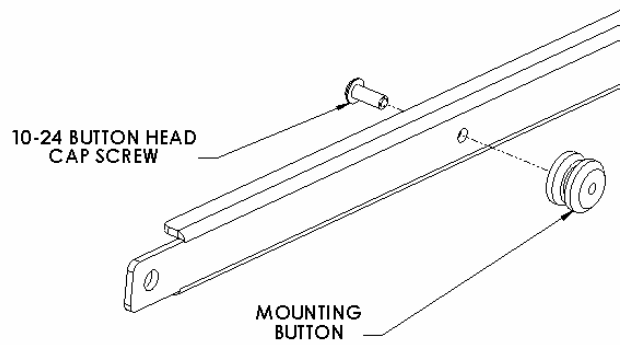

Figure 3

2. Attach center brackets to side brackets using the 1/4-20 screws (see Figure 3 & Figure 4).

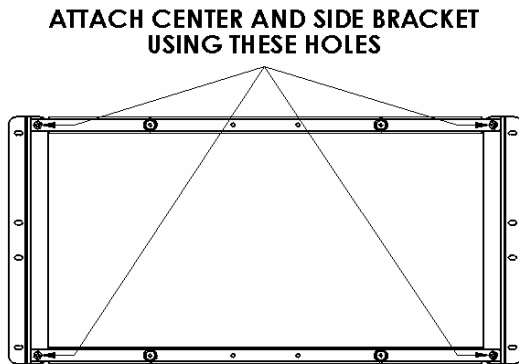

Figure 3

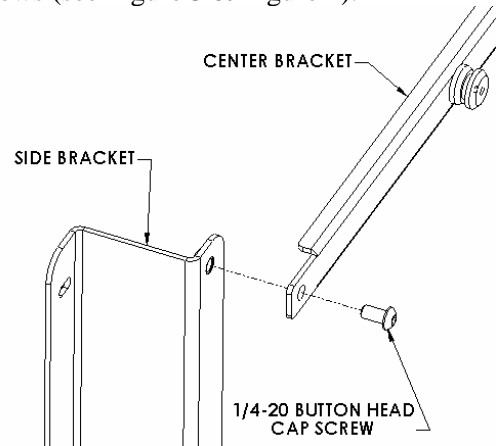

Figure 4

3. Using M5 screws and nylon spacers, secure side brackets to display (see Figure 5 & Figure 6). Do not over tighten screws. The 1/4-20 button head cap screws attaching the side and center brackets may need to be loosened in order to line up holes on display. If this is done, please be sure to tighten them once again.
4. With the aid of another person, lift LCD Display up to the Chief Mount, aligning buttons of mounting brackets with slots in the Chief Mount.
5. Lower safety latch on the Chief Mount to secure LCD Display, making sure latch is completely engaged.

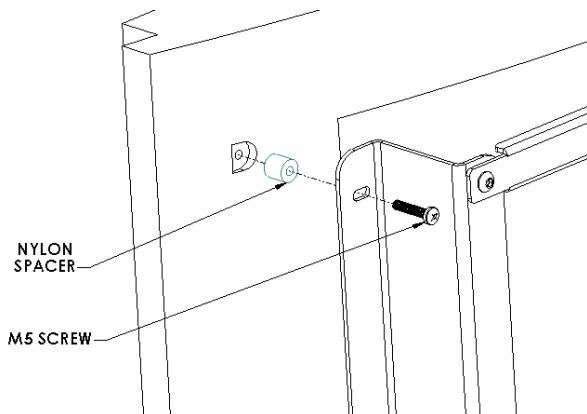

Figure 5

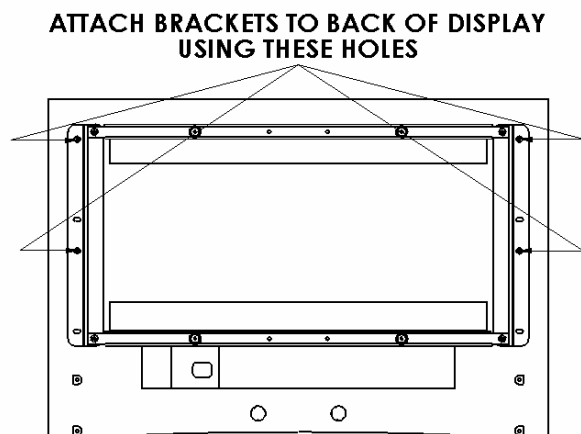

Figure 6