INSTALLATION INSTRUCTIONS

Plasma Wall Swing-Out (PWS) Wall Mount

The PWS wall mount is a rugged, versatile, and installer-friendly solution to unique display mounting requirements. This instruction manual contains instructions for Model PWS2000.

With the PWS securely mounted on a wall, simply hang your display like a picture (vertical or horizontal). Using the Q-latch mounting system permits you to hang and secure your display quickly.

The PWS allows you pull your display out 23.5" from the wall, pivot it up to 90 degrees left or right of center, traverse up to 22" left or right of center, and adjust the pitch 5 degrees up and 15 degrees down. The PWS also provides 2 degrees roll adjustment right and left for screen leveling.

Two electrical box openings in the wall plate is provided for cabling. The cable tray hides cables for aesthetics and cable protection.

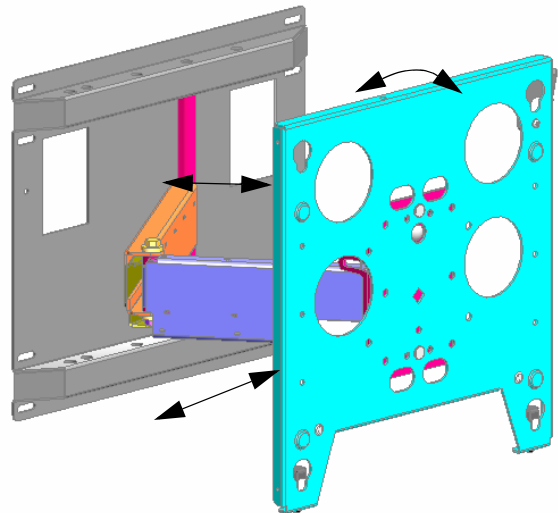

BEFORE YOU BEGIN

- **Caution:** To prevent damage to the PWS, which could affect or void the Factory warranty, and to the equipment that will be attached to it, thoroughly study all instructions and illustrations before you begin the installation. Pay particular attention to the “Important Warnings and Precautions” on Page 1.
- The maximum weight to be installed on the PWS wall mount is **100 pounds** (45.36Kg).
- The PWS wall mount is designed to be installed using wall studs or supporting framework. The wall to which the PWS wall mount is anchored must be capable of supporting *four times* the total weight of the mount and all attached equipment.
- If you have any questions about this installation, contact Chief Manufacturing at 1-800-582-6480.



IMPORTANT WARNINGS AND PRECAUTIONS!

- WARNING:** A **WARNING** alerts you to the possibility of serious injury or death if you do not follow the instructions.
- CAUTION:** A **CAUTION** alerts you to the possibility of damage or destruction of equipment if you do not follow the corresponding instructions.
- **WARNING: Improper installation can result in serious personal injury! Make sure that the structural members can support a redundant weight factor *four times* the total weight of the equipment: if not, reinforce the structure before installing the PWS.**
 - **WARNING: Be aware also of the potential for personal injury or damage to the unit if it is not adequately mounted.**
 - **WARNING: The installer is responsible for verifying that the wall, to which the PWS is anchored, will safely support the combined load of all attached components or other equipment.**
 - **WARNING: The weight of the display placed on the PWS must not exceed 100 lbs. (45.36 kg), the maximum load capacity of the PWS.**
 - **WARNING: Watch for pinch points. Do not put your fingers between movable parts.**
 - **CAUTION:** Check the unit for shipping damage before you begin the installation.

NOTE: Hardware for attaching this unit to the wall is not supplied.

TOOLS REQUIRED FOR INSTALLATION

- Electric drill and bit set
- Socket set with extension and open wrenches

NOTE: Other tools may be required depending on the method of installing the mount on the wall.

CONTENTS

DIMENSIONAL DRAWING	2
INSPECT THE UNIT BEFORE INSTALLING	3
PWS INSTALLATION	3
MOUNT THE DISPLAY	5
ADJUSTMENTS	4
Rotational Adjustment	4
Pitch Adjustment	4
Horizontal Adjustment	4
REMOVE THE DISPLAY	4

DIMENSIONAL DRAWING

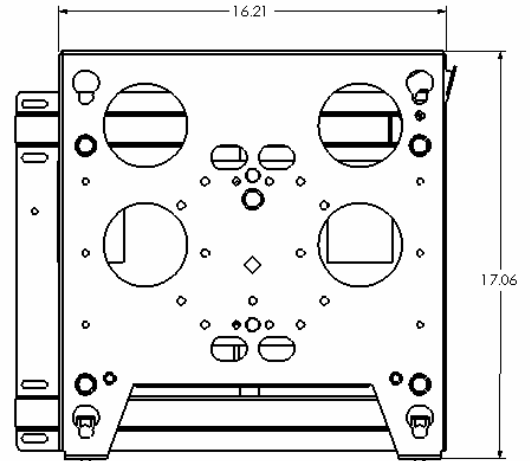
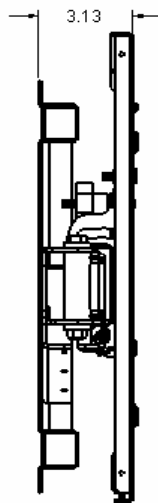
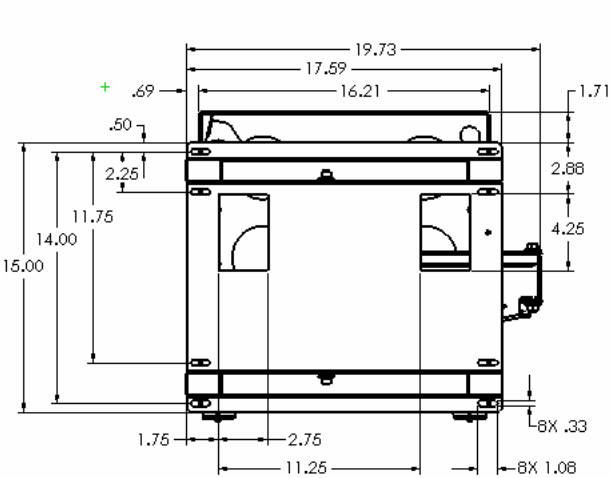
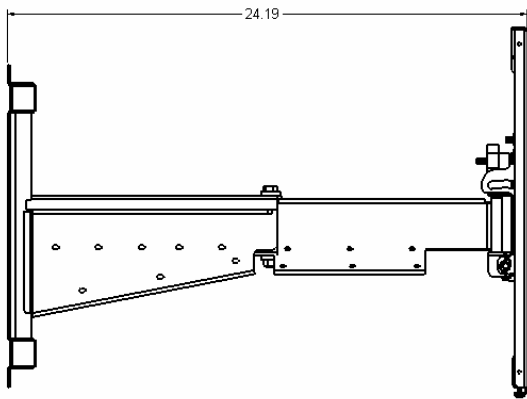
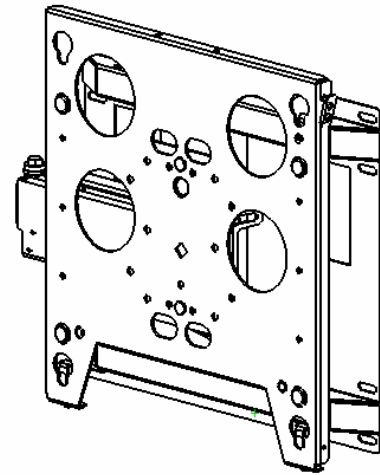
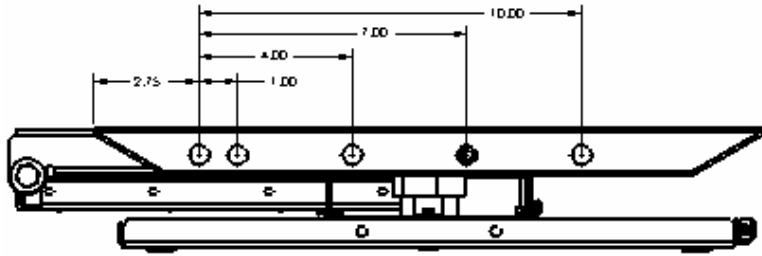
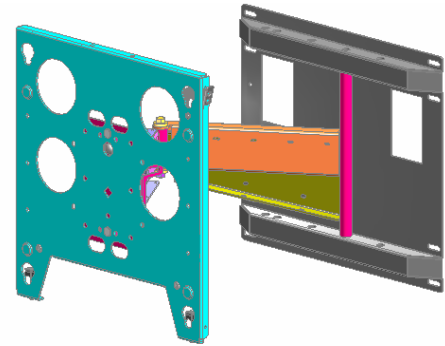
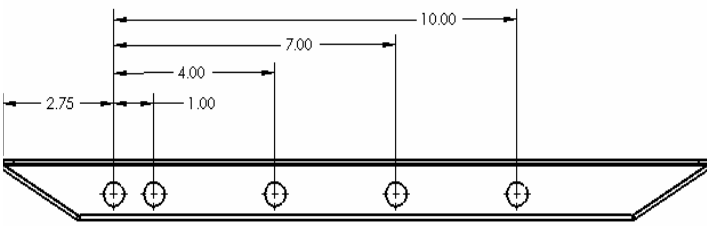

PWS Backing Plate Dimensions

INSPECT THE UNIT BEFORE INSTALLING

WARNING: Watch for pinch points. Do not put your fingers between movable parts.

1. Carefully inspect the PWS for shipping damage. If any damage is apparent, call your carrier claims agent and do not continue with the installation until the carrier has reviewed the damage.

NOTE: Read all instructions before starting installation.

2. Lay out components to ensure you have all the required parts before proceeding:

- 1 PWS (see PWS dimensional drawing on page 2)

PWS INSTALLATION

WARNING: It is the responsibility of the installer to verify that the wall to which the PWS is anchored will safely support the combined load of all attached components and equipment.

CAUTION: DO NOT attempt to mount the Flat Panel Display in an inverted position. Mounting the Flat Panel Display in an inverted position may cause overheating and extensive damage to the Flat Panel Display.

Install the PWS as follows:

1. Determine the exact mounting location prior to installation, considering the unit's total swing arm radius.
2. Using the wall plate as a pattern, transfer the mounting hole pattern to the wall.

NOTE: Notice the wall plate has a nominal hole (2"X4") to accommodate a duplex wall outlet.

3. Drill pilot holes at the desired height.

WARNING: Improper installation can result in serious personal injury! Make sure that the structural members can support a redundant weight factor *five times* the total weight of the equipment: if not, reinforce the structure before installing the PWS.

4. With the PWS correctly oriented and level, secure the PWS to the wall using a minimum of four fasteners (not included). Fasteners must be driven into the supporting wall studs or other supporting framework.

MOUNT THE DISPLAY

WARNING: Watch for pinch points. Do not put your fingers between movable parts.

1. For Model PWS2000 only, follow the instructions for installing the PSB bracket(s) of your specific flat panel display.
2. Before lifting your flat panel display, make sure the latch of the PWS is lowered and will not interfere with mounting the display (see Figure 1).
3. Using two people, align the Q-latch buttons with the Q-latch openings and install the display. Make sure the buttons of the Q-latch bracket fully engage all the Q-latch openings on the PWS (see Figure 2).
4. Secure the display to the PWS by completely engaging the latch (see Figure 3).
5. Connect and secure power/audio/video cables, making sure to leave sufficient slack to allow for movement of the swing arms.

ADJUSTMENTS

Rotational Adjustment

1. If necessary, loosen or tighten bottom rotational tilt tension adjustment nut (see Figure 4).
2. Mount the display and check for desired rotational tilt tension.
3. Repeat Steps 1 and 2 until desired rotational tilt tension is obtained.

Pitch Adjustment

1. Turn the T-knob handle until desired angle is achieved.
2. Make sure the carriage bolt is properly seated.

Horizontal Adjustment

1. Turn the display to desired horizontal position (max. 90 degrees).
2. Pull display from wall or push display back to wall.

REMOVE THE DISPLAY

1. Disconnect power/audio/video cables.
2. Disengage (lower) the latch.
3. Using two people, lift the display from the PWS.

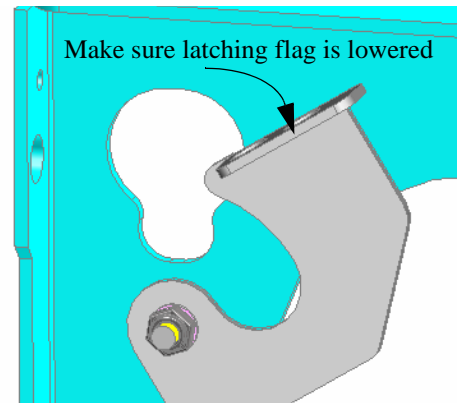

FIGURE 1. LOWER LATCH

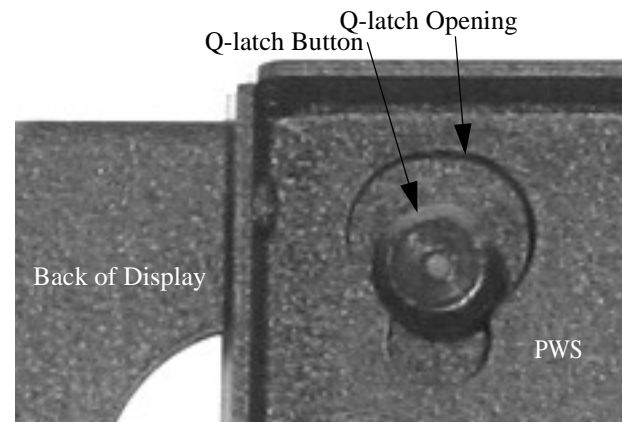

FIGURE 2. ENGAGE Q-LATCH

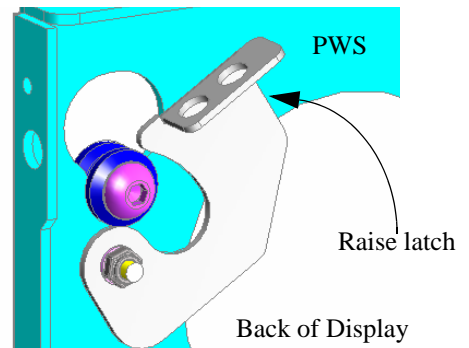

FIGURE 3. RAISE LATCH

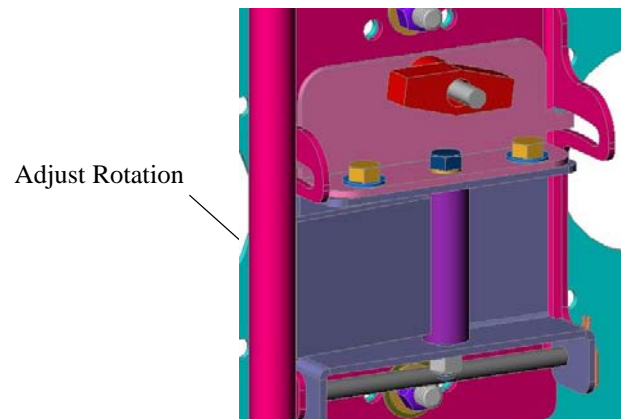

FIGURE 7. ADJUST ROTATION