

INSTALLATION INSTRUCTIONS

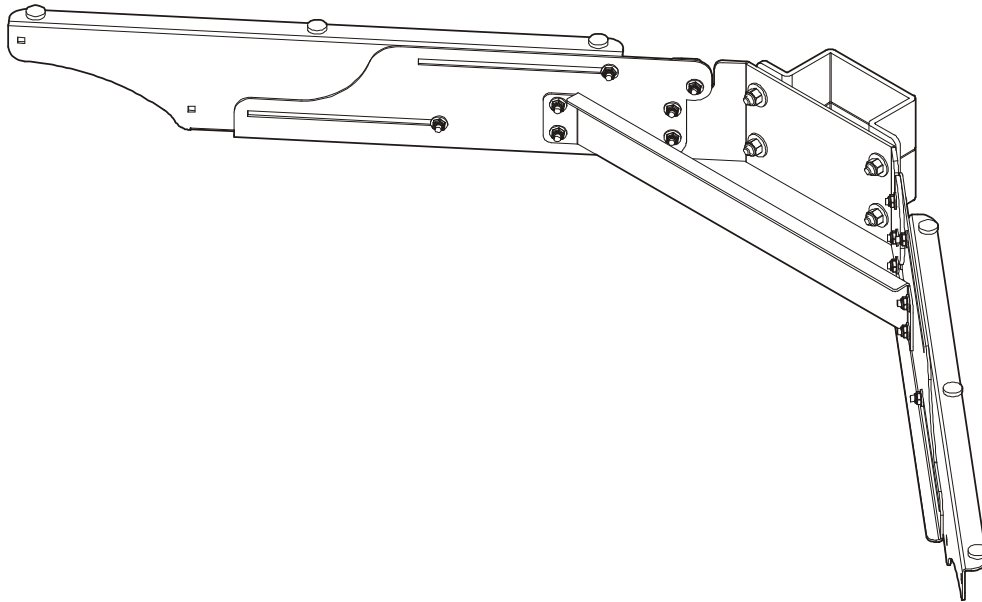

Music Stand Keyboard

DISCLAIMER

Milestone AV Technologies and its affiliated corporations and subsidiaries (collectively "Milestone"), intend to make this manual accurate and complete. However, Milestone makes no claim that the information contained herein covers all details, conditions or variations, nor does it provide for every possible contingency in connection with the installation or use of this product. The information contained in this document is subject to change without notice or obligation of any kind. Milestone makes no representation of warranty, expressed or implied, regarding the information contained herein. Milestone assumes no responsibility for accuracy, completeness or sufficiency of the information contained in this document.

Chief® is a registered trademark of Milestone AV Technologies. All rights reserved.

! IMPORTANT WARNINGS AND CAUTIONS!

! WARNING: A WARNING alerts you to the possibility of serious injury or death if you do not follow the instructions.

! CAUTION: A CAUTION alerts you to the possibility of

damage or destruction of equipment if you do not follow the corresponding instructions.

! WARNING: Failure to read, thoroughly understand, and follow all instructions can result in serious personal injury, damage to equipment, or voiding of factory warranty! It is the installer's responsibility to make sure all components are properly assembled and installed using the instructions provided.





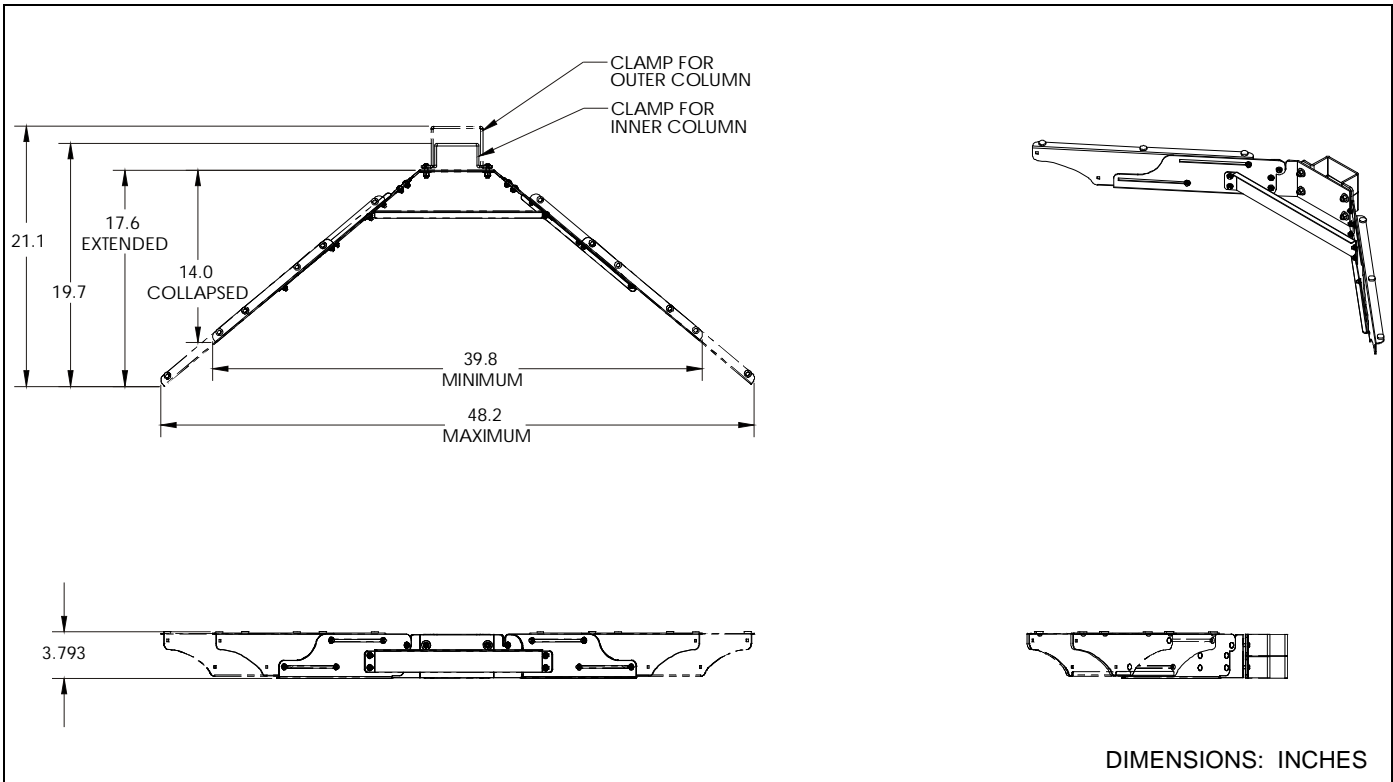

! WARNING: Failure to provide adequate structural strength for this component can result in serious personal injury or damage to equipment! It is the installer's responsibility to make sure the structure to which this component is attached can support five times the combined weight of all equipment. Reinforce the structure as required before installing the component.

! WARNING: Exceeding the weight capacity can result in serious personal injury or damage to equipment! It is the installer's responsibility to make sure the combined weight of all components attached to this accessory does not exceed 70 lbs (31.8 kg).

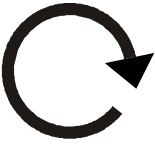
DIMENSIONS

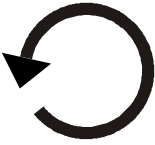

LEGEND

	<table border="1"> <thead> <tr> <th>Tighten Fastener</th> </tr> </thead> <tbody> <tr><td>Apretar elemento de fijación</td></tr> <tr><td>Befestigungsteil festziehen</td></tr> <tr><td>Apertar fixador</td></tr> <tr><td>Serrare il fissaggio</td></tr> <tr><td>Bevestiging vastdraaien</td></tr> <tr><td>Serrez les fixations</td></tr> </tbody> </table>	Tighten Fastener	Apretar elemento de fijación	Befestigungsteil festziehen	Apertar fixador	Serrare il fissaggio	Bevestiging vastdraaien	Serrez les fixations		<table border="1"> <thead> <tr> <th>Hex-Head Wrench</th> </tr> </thead> <tbody> <tr><td>Llave de cabeza hexagonal</td></tr> <tr><td>Sechskantschlüssel</td></tr> <tr><td>Chave de cabeça sextavada</td></tr> <tr><td>Chiave esagonale</td></tr> <tr><td>Zeskantsleutel</td></tr> <tr><td>Clé à tête hexagonale</td></tr> </tbody> </table>	Hex-Head Wrench	Llave de cabeza hexagonal	Sechskantschlüssel	Chave de cabeça sextavada	Chiave esagonale	Zeskantsleutel	Clé à tête hexagonale
Tighten Fastener																	
Apretar elemento de fijación																	
Befestigungsteil festziehen																	
Apertar fixador																	
Serrare il fissaggio																	
Bevestiging vastdraaien																	
Serrez les fixations																	
Hex-Head Wrench																	
Llave de cabeza hexagonal																	
Sechskantschlüssel																	
Chave de cabeça sextavada																	
Chiave esagonale																	
Zeskantsleutel																	
Clé à tête hexagonale																	
	<table border="1"> <thead> <tr> <th>Loosen Fastener</th> </tr> </thead> <tbody> <tr><td>Aflojar elemento de fijación</td></tr> <tr><td>Befestigungsteil lösen</td></tr> <tr><td>Desapertar fixador</td></tr> <tr><td>Allentare il fissaggio</td></tr> <tr><td>Bevestiging losdraaien</td></tr> <tr><td>Desserrez les fixations</td></tr> </tbody> </table>	Loosen Fastener	Aflojar elemento de fijación	Befestigungsteil lösen	Desapertar fixador	Allentare il fissaggio	Bevestiging losdraaien	Desserrez les fixations		<table border="1"> <thead> <tr> <th>Open-Ended Wrench</th> </tr> </thead> <tbody> <tr><td>Llave de boca</td></tr> <tr><td>Gabelschlüssel</td></tr> <tr><td>Chave de bocas</td></tr> <tr><td>Chiave a punte aperte</td></tr> <tr><td>Steeksleutel</td></tr> <tr><td>Clé à fourche</td></tr> </tbody> </table>	Open-Ended Wrench	Llave de boca	Gabelschlüssel	Chave de bocas	Chiave a punte aperte	Steeksleutel	Clé à fourche
Loosen Fastener																	
Aflojar elemento de fijación																	
Befestigungsteil lösen																	
Desapertar fixador																	
Allentare il fissaggio																	
Bevestiging losdraaien																	
Desserrez les fixations																	
Open-Ended Wrench																	
Llave de boca																	
Gabelschlüssel																	
Chave de bocas																	
Chiave a punte aperte																	
Steeksleutel																	
Clé à fourche																	
	<table border="1"> <thead> <tr> <th>By Hand</th> </tr> </thead> <tbody> <tr><td>A mano</td></tr> <tr><td>Von Hand</td></tr> <tr><td>Com a mão</td></tr> <tr><td>A mano</td></tr> <tr><td>Met de hand</td></tr> <tr><td>À la main</td></tr> </tbody> </table>	By Hand	A mano	Von Hand	Com a mão	A mano	Met de hand	À la main		<table border="1"> <thead> <tr> <th>Socket Wrench</th> </tr> </thead> <tbody> <tr><td>Llave de cubo</td></tr> <tr><td>Steckschlüssel</td></tr> <tr><td>Chave de caixa</td></tr> <tr><td>Chiave a brugola</td></tr> <tr><td>Dopsleutel</td></tr> <tr><td>Clé à douilles</td></tr> </tbody> </table>	Socket Wrench	Llave de cubo	Steckschlüssel	Chave de caixa	Chiave a brugola	Dopsleutel	Clé à douilles
By Hand																	
A mano																	
Von Hand																	
Com a mão																	
A mano																	
Met de hand																	
À la main																	
Socket Wrench																	
Llave de cubo																	
Steckschlüssel																	
Chave de caixa																	
Chiave a brugola																	
Dopsleutel																	
Clé à douilles																	

TOOLS REQUIRED FOR INSTALLATION

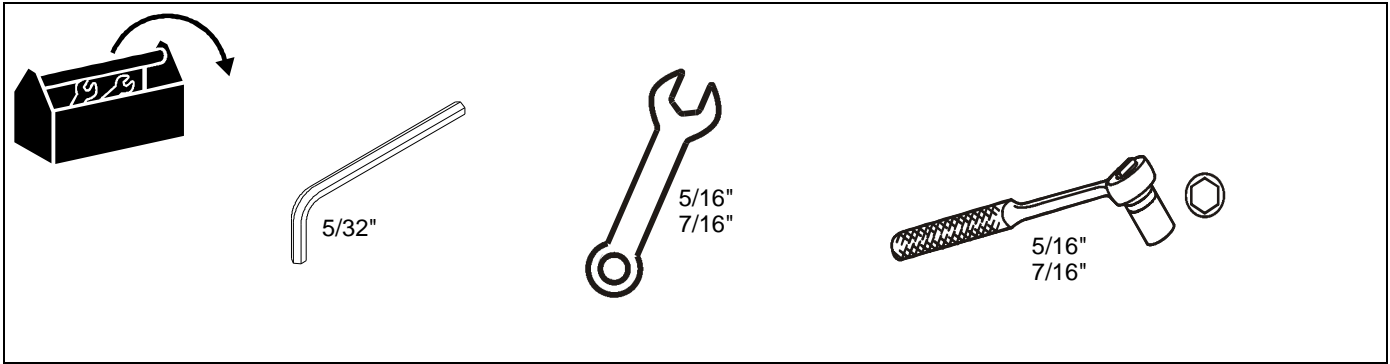

PARTS

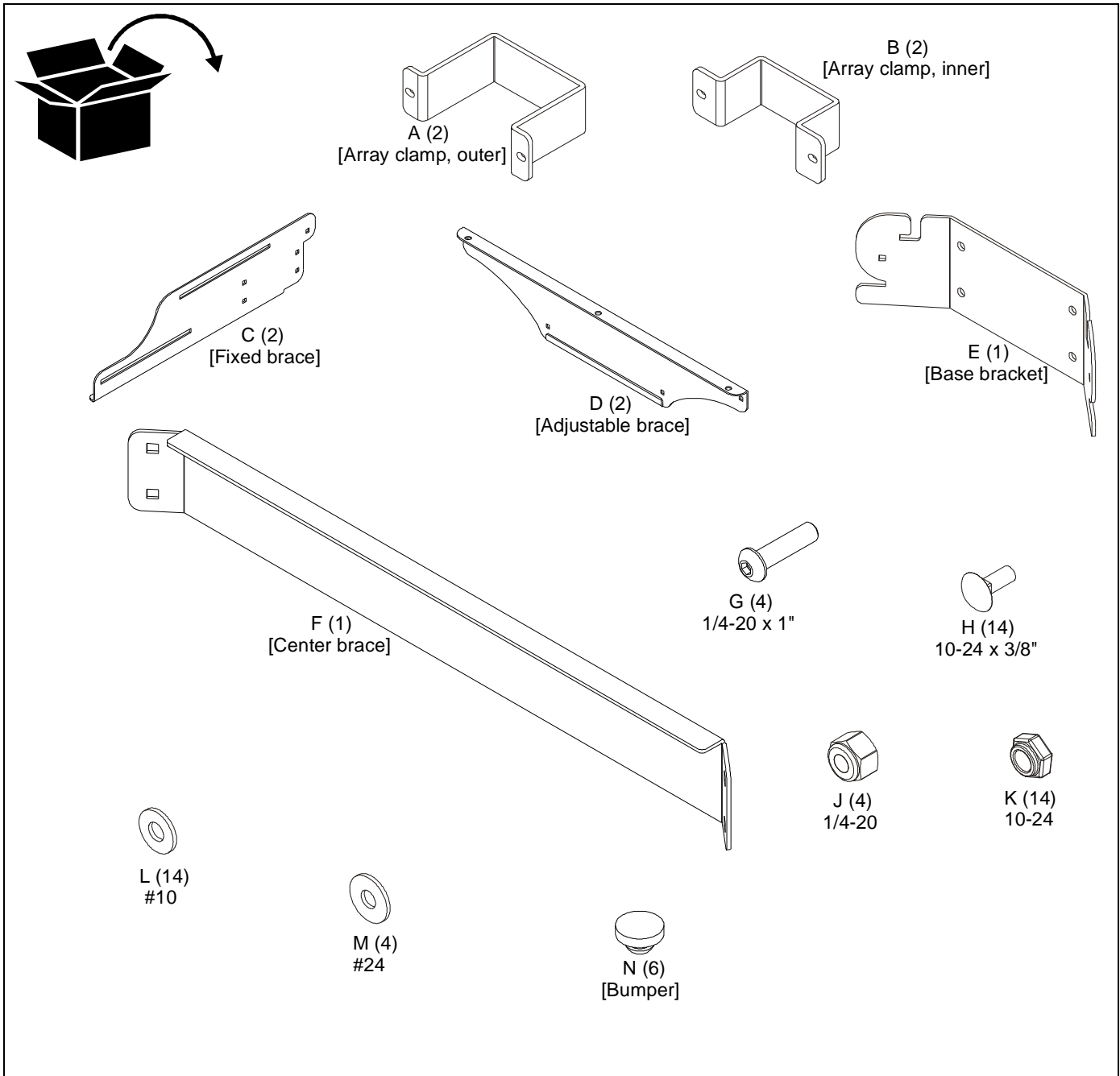

ASSEMBLY AND INSTALLATION



WARNING: IMPROPER INSTALLATION CAN LEAD TO EQUIPMENT FALLING CAUSING SERIOUS PERSONAL INJURY OR DAMAGE TO EQUIPMENT! DO NOT substitute hardware! Use only hardware provided by manufacturer.



WARNING: EXCEEDING MAXIMUM WEIGHT CAPACITY MAY LEAD TO SERIOUS PERSONAL INJURY OR DAMAGE TO EQUIPMENT! It is the user's responsibility to ensure the total amount of weight placed on the keyboard stand does not exceed 70 lbs (31.8 kg).

Assembly of Keyboard Shelf

The QMP1MK is designed to be mounted onto the QMP1FB stand or the QMP1MB cart. The shelf can be installed either below or above the adjustment knob on the cart/stand column.

1. Attach adjustable brace (D) to fixed brace (C) using two 10-24 x 3/8 round head carriage bolts (H), two #10 flat washers (L) and two 10-24 nylon lock nuts (K). (See Figure 1)
2. Repeat Step 1 for remaining adjustable brace (D) and fixed brace (C).

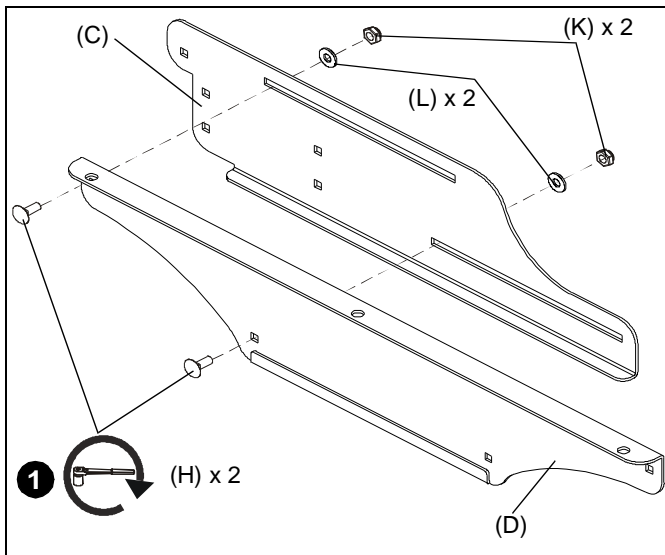

Figure 1

3. Attach one brace assembly which was created in Steps 1 and 2, to the base bracket (E) using three 10-24 x 3/8 round head carriage bolts (H), three #10 flat washers (L) and three 10-24 nylon lock nuts (K). (See Figure 2)
4. Repeat Step 3 to attach remaining brace assembly onto other end of base bracket (E).

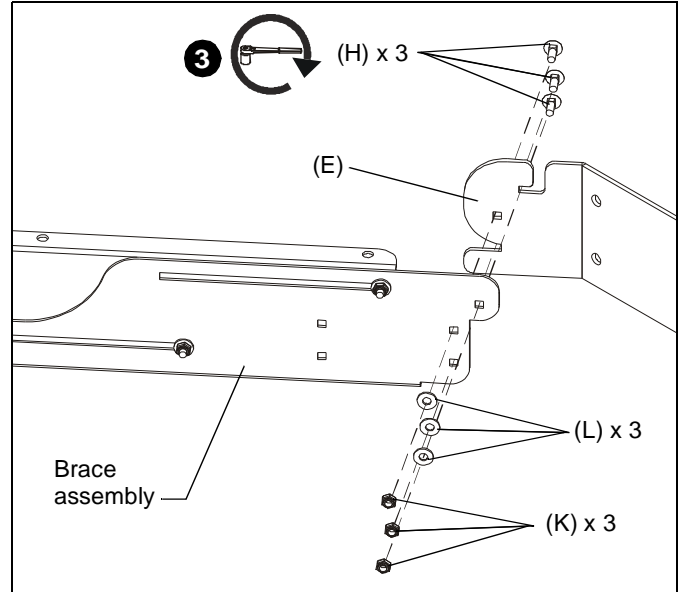

Figure 2

5. Attach center brace (F) to base bracket assembly using four 10-24 x 3/8 round head carriage bolts (H), four #10 flat washers (L) and four 10-24 nylon lock nuts (K). (See Figure 3)

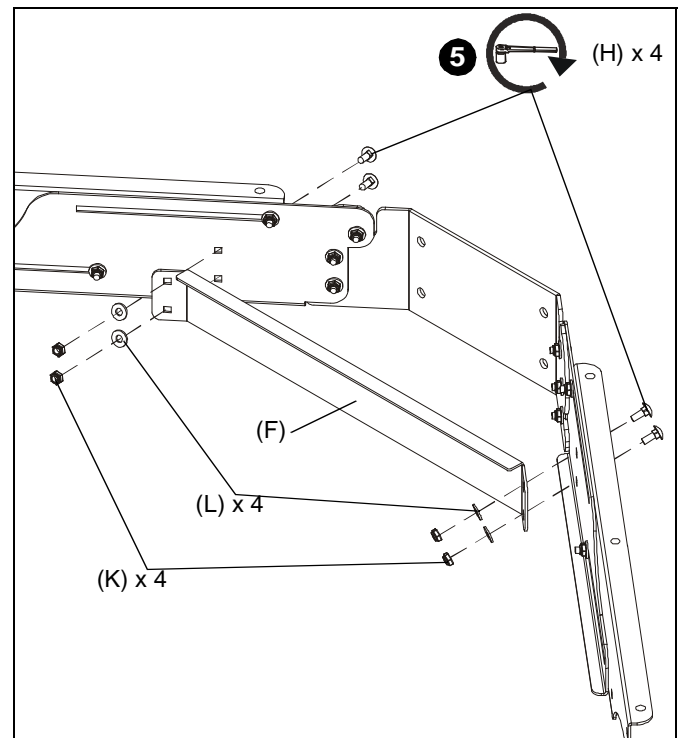

Figure 3

6. Choose appropriate array clamps to complete bracket assembly to cart/stand.
 - Array clamp, outer (A) is used to attach keyboard shelf to OUTER column of cart/stand (below adjustment knob).
 - Array clamp, inner (B) is used to attach keyboard shelf to INNER column of cart/stand (above adjustment knob).

- Attach two array clamps (A or B) to bracket assembly using four 1/4-20 x 1" button head cap screws (G), four #24 flat washers (M) and four 1/4-20 nylon lock nuts (J). (See Figure 4)

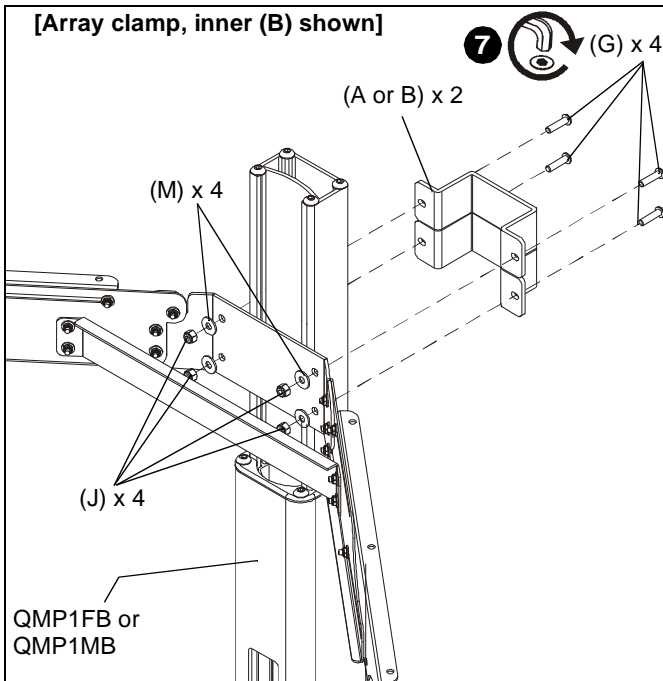

Figure 4

- Add six rubber bumpers (N) to top of bracket assembly. (See Figure 5)

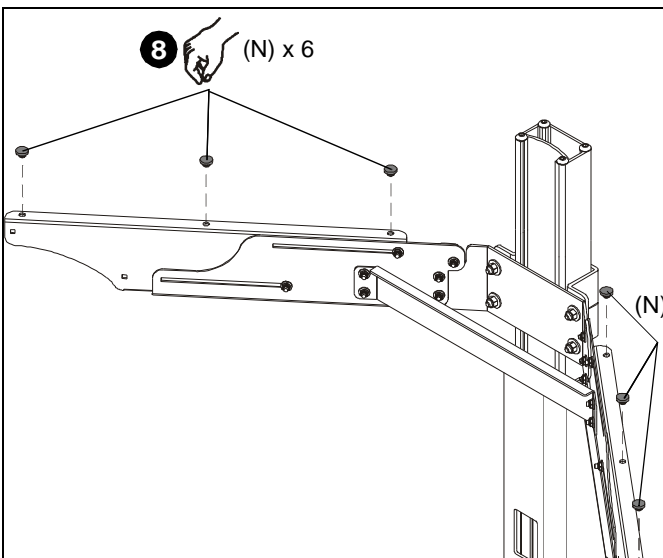

Figure 5

IMPORTANT ! : The maximum distance allowed between the **top** of the array clamp holding the bracket assembly in place and the **floor** is 48 inches. (See Figure 6)

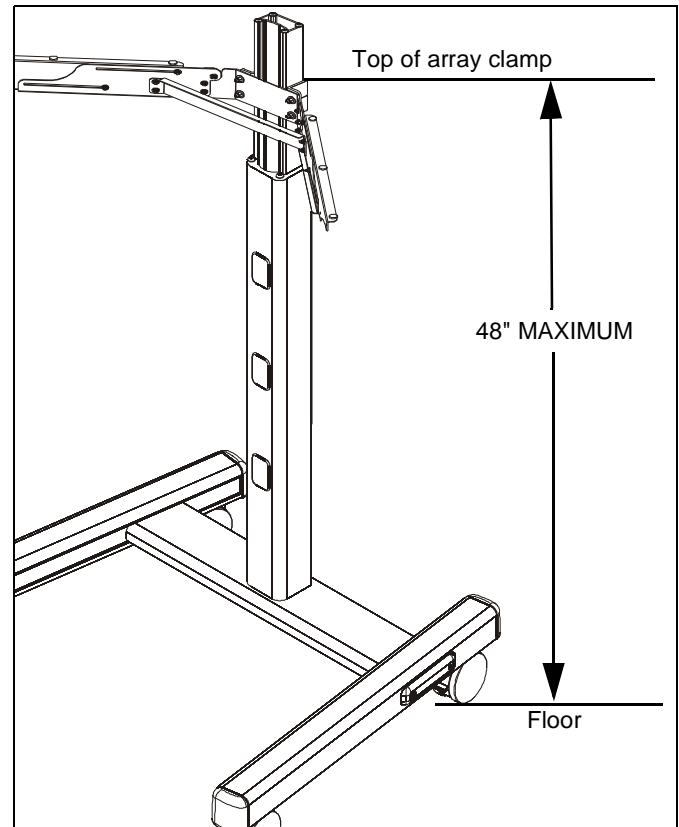

Figure 6



CAUTION: This shelf is intended for use with equipment weighing not more than 70 lbs (31.8 kg) and having dimensions that will permit it to sit evenly on this shelf. Use with other equipment may result in instability causing possible injury.



CAUTION: Do NOT sit or hang on the shelf. Such use may result in instability causing possible injury and damage to equipment.



CAUTION: Equipment **MUST** be fastened to the shelf before moving the cart or stand. If equipment is not fastened to the shelf it **MUST** be removed before moving the cart or stand.

Cable Management

Follow cable management instructions in the stand or cart installation instructions.



Our Mounts. **Your Vision.**

Chief, a products division of
Milestone AV Technologies

8800-002929 Rev00
©2016 Milestone AV Technologies
www.milestone.com
12/16

USA/International	A 6436 City West Parkway, Eden Prairie, MN 55344 P 800.582.6480 / 952.225.6000 F 877.894.6918 / 952.894.6918
Europe	A Franklinstraat 14, 6003 DK Weert, Netherlands P +31 (0) 495 580 852 F +31 (0) 495 580 845
Asia Pacific	A Office No. 918 on 9/F, Shatin Galleria 18-24 Shan Mei Street Fotan, Shatin, Hong Kong P 852 2145 4099 F 852 2145 4477

