

---

# INSTALLATION INSTRUCTIONS

---

## MSP-SPFB (PFB-2000S) Plasma Floor Stand

Chief's Plasma Floor Stand is a safe, stable, easy-to-install modular design solution for digital signage and presentations. Ideal where wall or ceiling mounting is impractical, the floor stand offers maximum exposure and security for your display.

The flat base of the Plasma Floor Stand can be free standing or anchored and can be concealed under carpeting for easy traffic around the display. The Single Baseplate model supports one or more displays facing in one direction and accommodates horizontal (landscape) or vertical (portrait) mounting of your display and your display(s) can be mounted anywhere along the vertical poles to achieve the perfect viewing height.

Additional displays can be stacked by ordering additional attachment heads (PAC-142). Small Flat Panel Displays may be mounted using Chief accessories (PAC-144).

Using Chief's exclusive Q-latch® Mounting System for easy installation, the Floor Stand provides stable mounting, quick release and optional security.

Q-Latch® is a registered trademark of Chief Manufacturing, Inc.

All rights reserved.

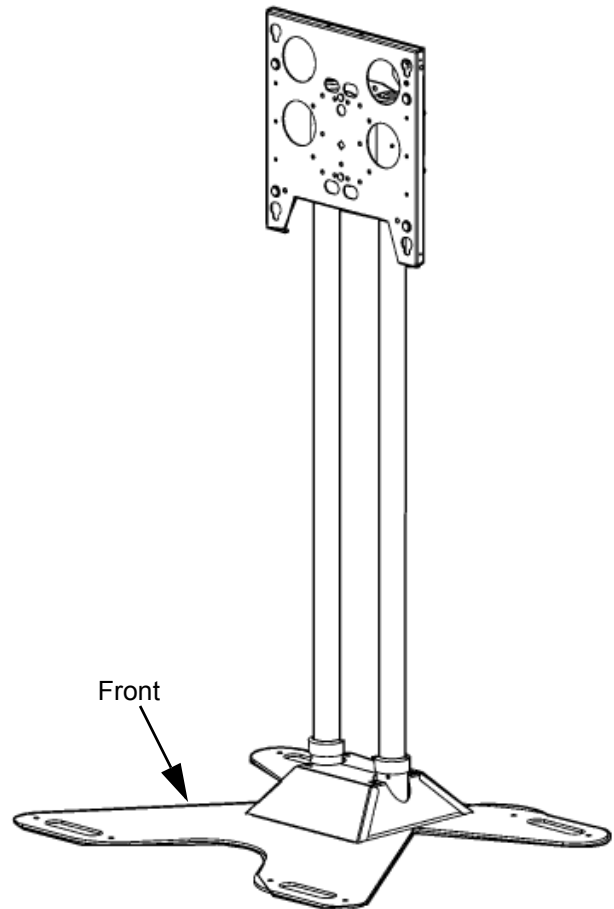

---

### BEFORE YOU BEGIN

---

**CAUTION:** To prevent damage to the Plasma Floor Stand, which could affect or void the Factory warranty, thoroughly study all instructions and illustrations before you begin to assemble the unit. Pay particular attention to the "Important Warning and Cautions" on Page 2.

- You must have (order separately) the correct adapter (PSB) for your display model.
- The maximum weight to be installed on the Plasma Floor Stand is 300 pounds (136.08 kg).
- If you have any questions about this assembly, contact Chief Manufacturing at 1-952-894-6280.



## IMPORTANT WARNINGS and CAUTIONS!

**WARNING:** A WARNING alerts you to the possibility of serious injury or death if you do not follow the instructions.

**CAUTION:** A CAUTION alerts you to the possibility of damage or destruction of equipment if you do not follow the corresponding instructions.

**WARNING:** Make sure to place the Plasma Floor Stand on a smooth, level surface.

**WARNING:** Improper installation can result in serious personal injury! Make sure that the structural members can support a redundant weight factor five times the total weight of the equipment. If the structure can not support this weight, reinforce the structure before completing installation.

**WARNING:** Do not attempt to hang the Plasma Display Panel onto the Plasma Floor Stand alone. Always use two people to hang the Plasma Display Panel.

**CAUTION:** Inspect the unit for shipping damage.

## TOOLS REQUIRED FOR INSTALLATION

- 7/16", 1/2" and 9/16" wrench
- Phillips Head Screwdriver
- Allen wrenches
- Socket set with extension

**NOTE:** Other tools may be required depending on the method of installation.

## CONTENTS

IMPORTANT WARNINGS and CAUTIONS! .....	2
TOOLS REQUIRED FOR INSTALLATION .....	2
IDIMENSIONAL DRAWING .....	3
INSPECT PARTS BEFORE ASSEMBLY .....	4
ASSEMBLE PLASMA FLOORSTAND .....	5
Base Plate Installation .....	5
Floor Stand Assembly .....	6
INSTALL PSB-2095 .....	7
MOUNT THE DISPLAY .....	9
ROLL ADJUSTMENT .....	10

### DIMENSIONAL DRAWING

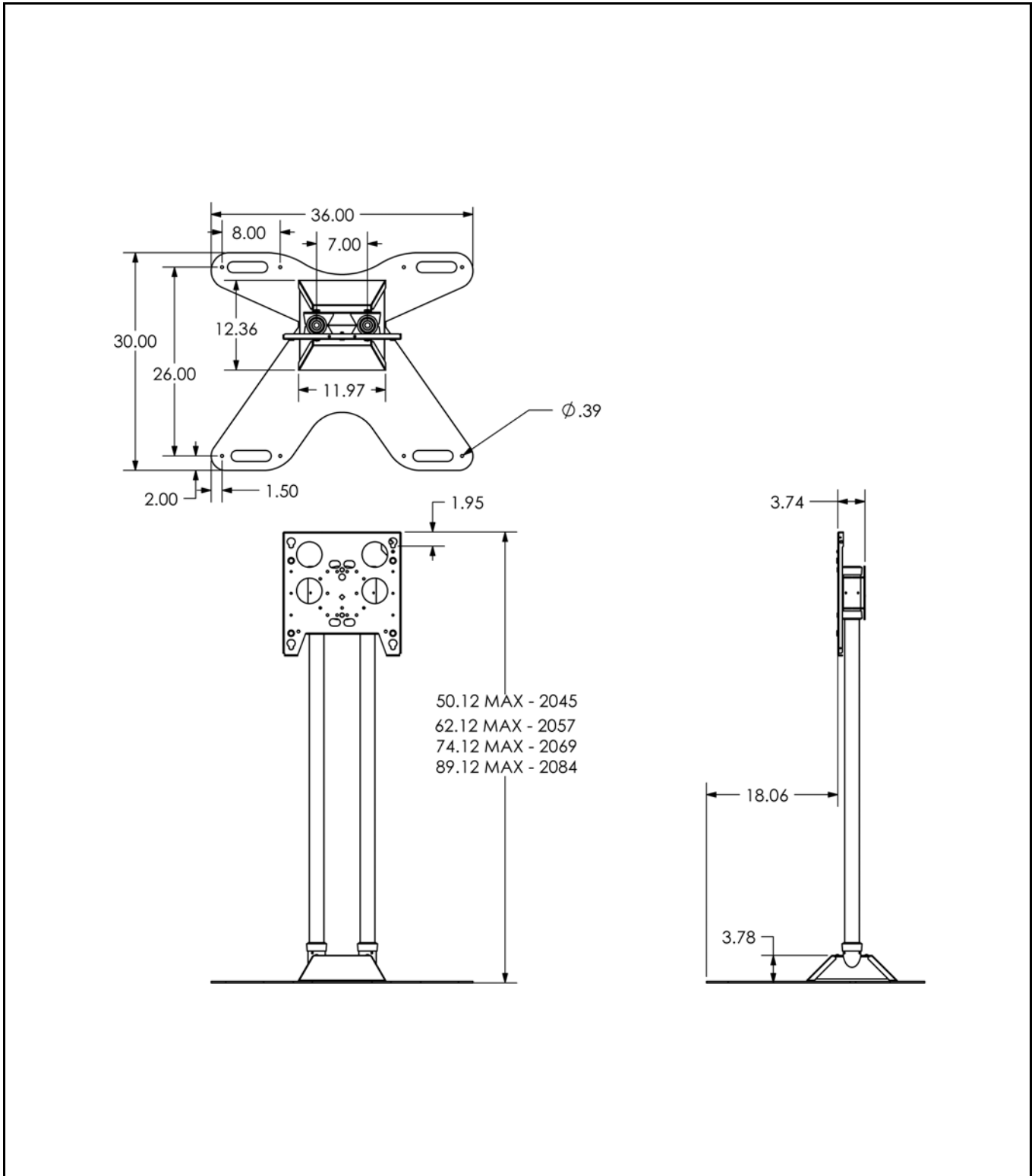

**INSPECT PARTS BEFORE ASSEMBLY**

Inspect The Plasma Floor Stand

1. Carefully inspect the Plasma Floor Stand (see figure 1) components for shipping damage. If any damage is apparent, call your carrier claims agent and do not continue with the assembly procedure until the carrier has reviewed the damage.

**NOTE:** Read all assembly instructions thoroughly before assembly.

**Table 1: Parts**

Item#	Description	Qty.
10	BASE	1
20	PLATE, Single Base, Front	1
30	PLATE, Single Base, Back	1
40	SCREW, Cap, Flat Head 3/8" x 1"	8
50	NUT, Nylock, 3/8-16	8
60	TUBE (45", 57", 69" or 84")	2
70	SCREW, Set, Socket Head, 5/16-18 X 3/8"	4
80	COVER, Base	2
90	SCREW, Phillips, 10-24 X 3/8"	4
100	Head Assembly, Single Screen Mounting	1
110	WRENCH, Allen, 5/32"	1
120	WRENCH, Allen, 7/32"	1
130	SCREW, SET, SOCKET HEAD, 5/16-18 x 1/2"	4

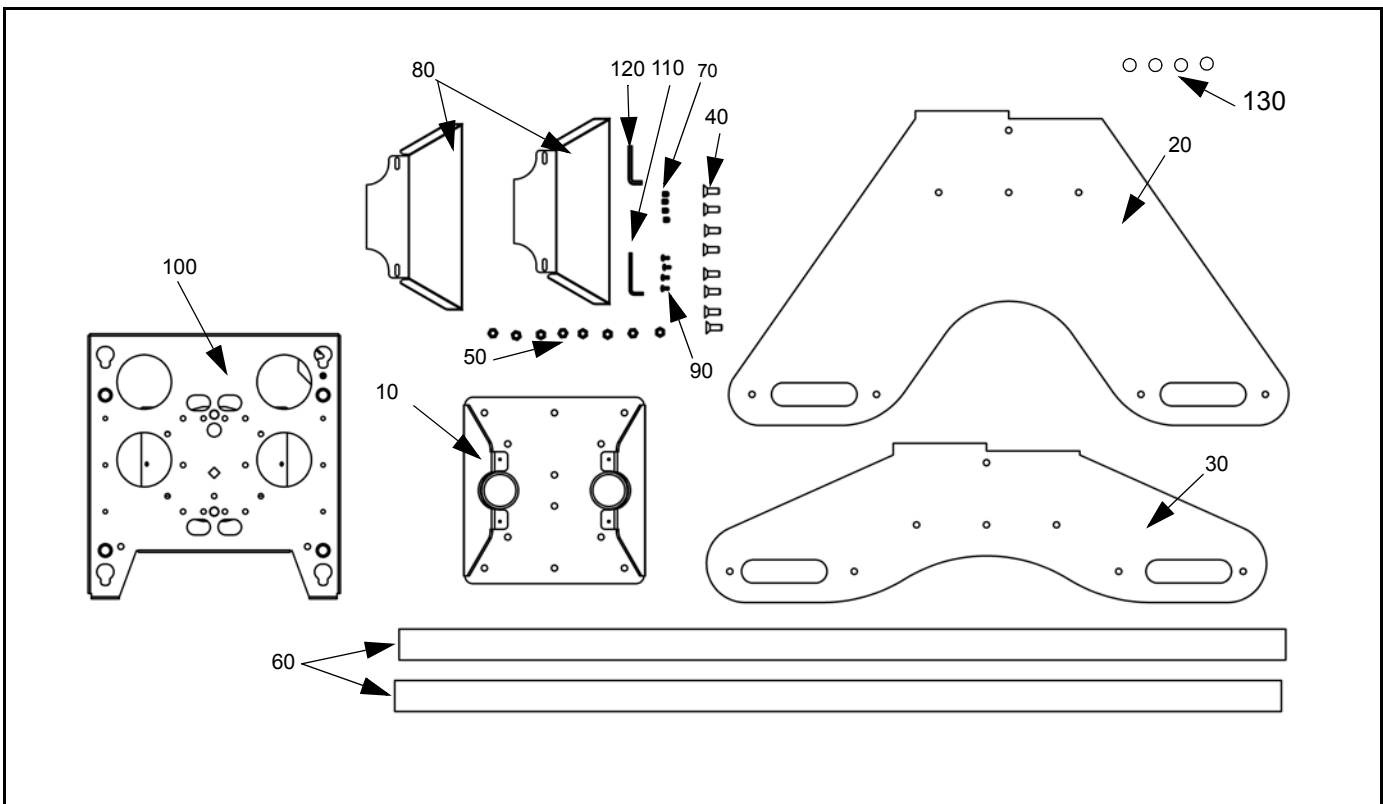

**Figure 1: Parts**

**Table 2: Optional Accessories**

Item	Description	Qty.
PAC-141	HEAD, Dual, Large Flat Screen	1
PAC-142	HEAD, Single, Large Flat Screen	1
PAC-143	HEAD, Dual, Small Flat Screen	1
PAC-144	HEAD, Single, Small Flat Screen	1
PAC-145	BASE, Assembly, Single Sided	1
PAC-146	BASE, Assembly, Bolt Down Center	1
PAC-147	BASE, Assembly, Back-To-Back	1
PAC-150	SHELF, Accessory, Video Conferencing	1
PAC-152	HEAD, Single, with Tilt	1
PAS-1	SHELF, Dual Post	1
USA-1	SHELF, Swivel	1
PAC-140	Q-clamps	2

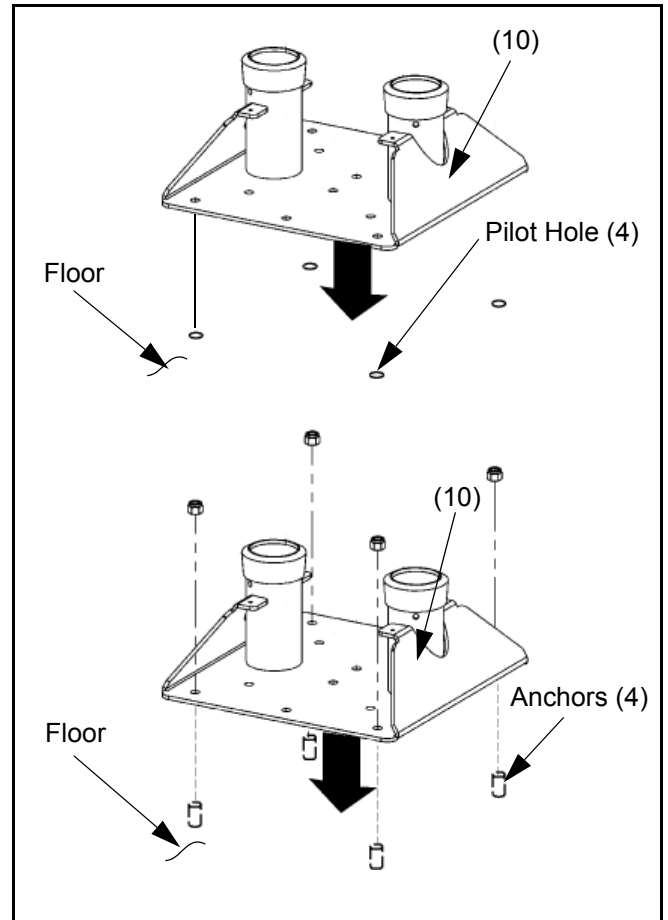

**Figure 2: Install Base To Floor**

**ASSEMBLE PLASMA FLOORSTAND**

Numbers in ( ) refer to parts shown in Figure 2.

To assemble Floor Stand:

1. Place Base (10) at desired location on floor, ensuring location is flat, and capable of supporting five times the combined weight of the stand and all equipment mounted on the stand.
2. Using Base (10) as a template, mark anchor locations on floor.
3. Remove Base (10), drill and install anchors
4. Place Base (10) over anchors.
5. Secure Base (10) to anchors using appropriate mounting hardware. (see figure 2)

**Base Plate Installation**

1. Place Base (10) upside down
2. Secure Front Single Base Plate (20) and Back Single Base Plate (30) using eight flat head cap screws (40) and eight 3/8-16 Nylock nuts (50) (see figure 3).
3. Place Base (10) upright.

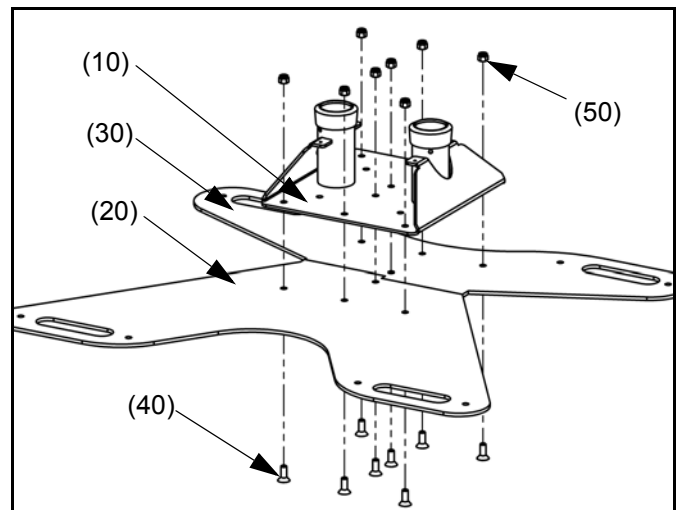

**Figure 3: Install Single Base Plates**

### Floor Stand Assembly

1. Install two Tubes (60) in Base (10) (see figure 4).
2. Secure tubes (60) using four 5/16-18 X 3/8 socket head set screws (70), (see figure 5).
3. Install two base covers (80) and secure using four 10-24 X 3/8"Phillips screws (90) (see figure 6).
4. Install single screen mounting bracket (100) on tubes (60), set at desired height, and secure using four 5/16-18 X 3/8 socket head set screws (70) (see figure 7) and (see figure 8).

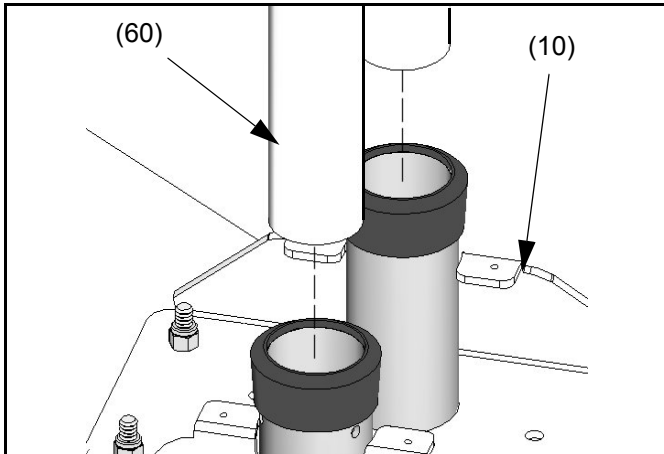

Figure 1: Install Tube(s)

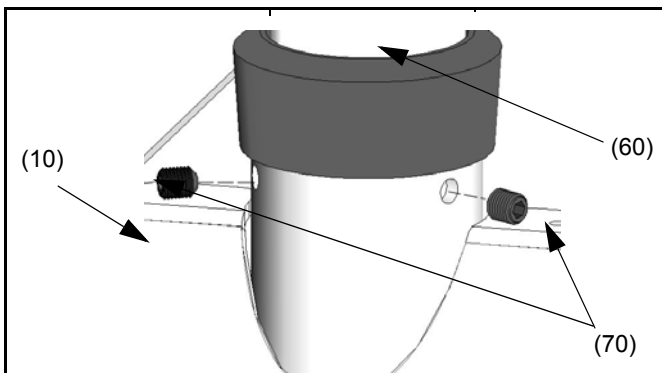

Figure 2: Secure Tube(s)

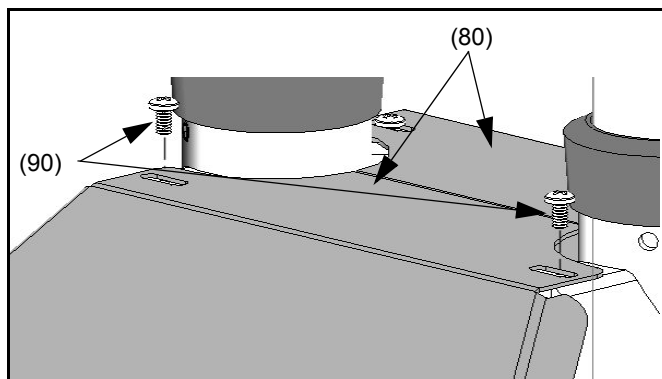

Figure 3: Install Base Covers

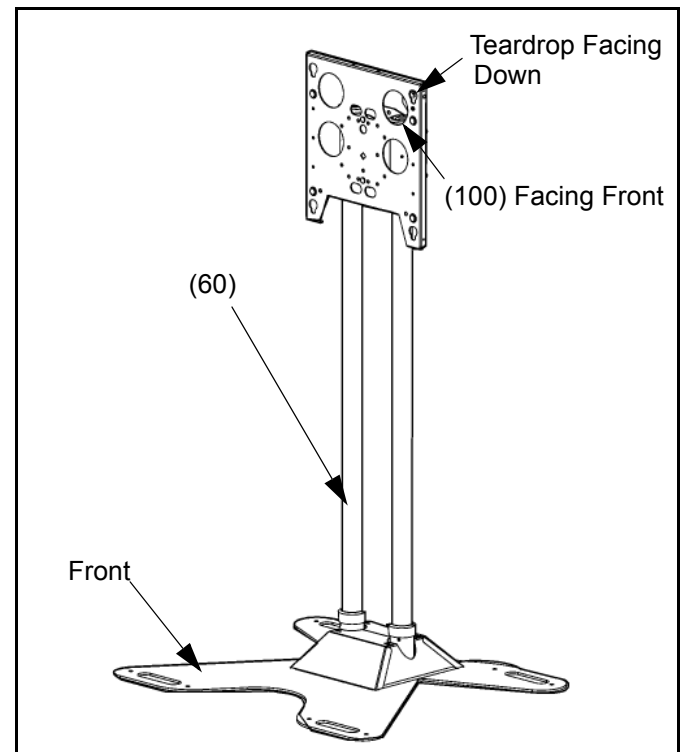

Figure 4: Floorstand Component Orientation

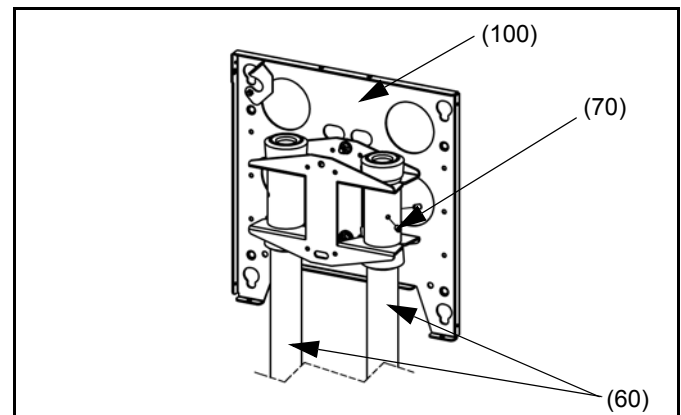

Figure 5: Mount Faceplate

**INSTALL PSB-2095**

The PSB-2095 parts list is shown in the table on this page.

1. Using a 10-24 button head cap screw inserted from the backside of the bracket (see Figure 6), secure the mounting button with the chamfered hole of mounting button (larger surface) facing the bracket (see Figure 7).
2. Repeat Step 1 to install the other three mounting buttons.

REF	DESCRIPTION	QTY
10	Plasma Bracket	1
20	10-24 x 1/2 Button Head Cap Screw	4
30	M5 x 20mm Button Head Cap Screw	4
40	M6 x 20mm Button Head Cap Screw	4
50	Mounting Buttons – Tapped	4
60	1/8" Allen Key	1
70	.875 OD x .33 ID x .375 Nylon Spacer	4
80	M4 Allen Key	1

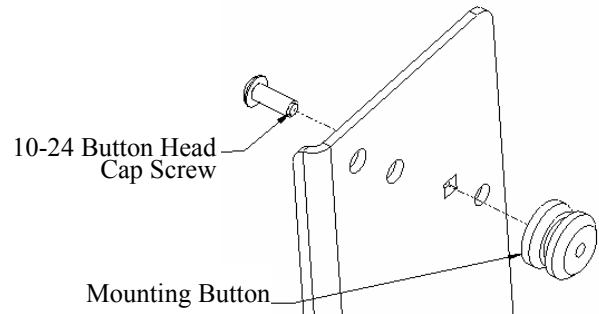

Figure 6. Mounting Button Attachment

Attach Mounting Buttons  
Using These Holes

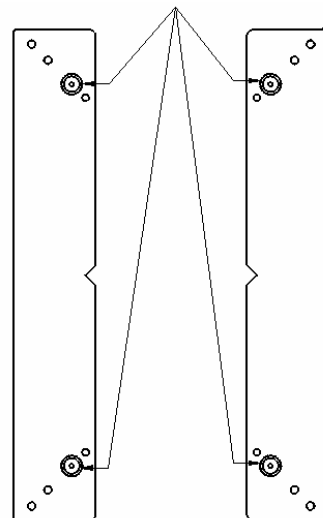

Figure 7. Mounting Button Location

**INSTALL PSB-2095 (CONT'D)**

3. Place nylon spacers over the mounting holes on the back of the screen (see Figure 8).
4. Attach mounting bracket to the display (see Figure 9), as follows:
  - a. For 32" screens, use the M5 screws.
  - b. For 42" and 50" screens, use the M6 screws.

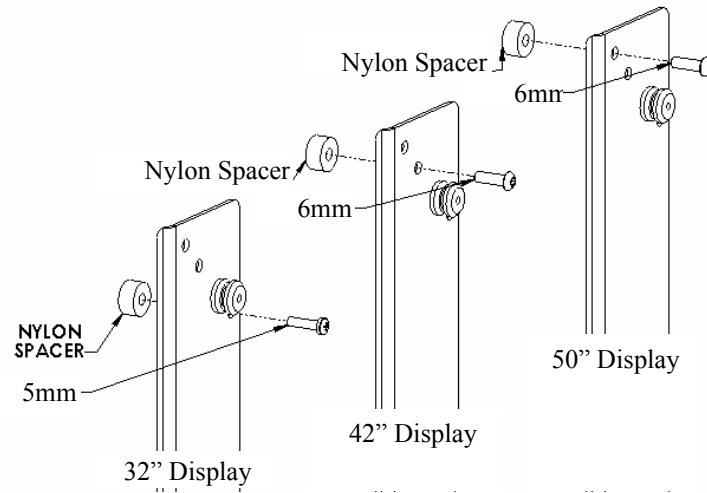

Figure 8. Bracket Hole Location

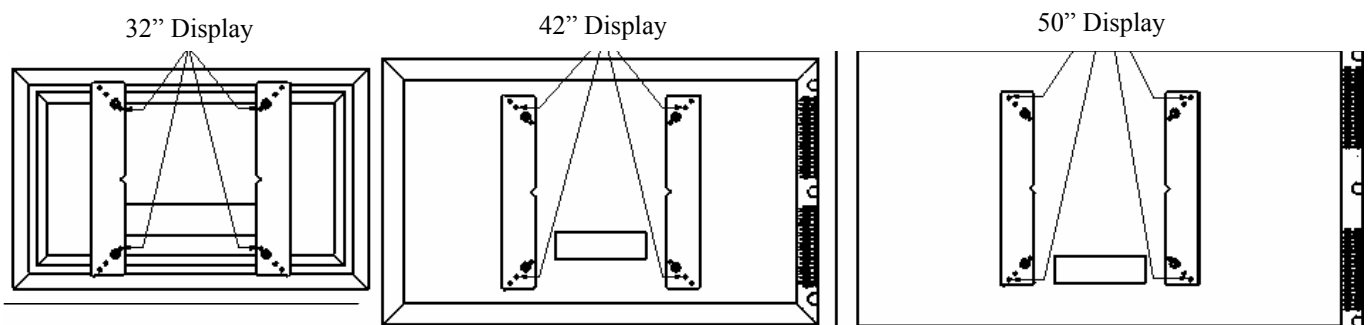

Figure 9. Bracket Attachment Location



## MOUNT THE DISPLAY

1. Follow the instructions for installing the PSB bracket(s) for your specific flat panel display.

**WARNING:** Watch for pinch points. Do not put your fingers between movable parts.

**NOTE:** Before lifting your flat panel display, make sure the Q-latch on the PFB is lowered and will not interfere with mounting the display.

2. Open the Q-latch (see Figure 10).
3. With an assistant, lift the display up to the mount and align the mounting buttons (on the PFB bracket) with the teardrop slots on the faceplate. Make sure mounting buttons fully engage all the teardrop slots on the faceplate (see Figure 11).
4. Secure the display to the PFB by completely engaging the Q-latch (see Figure 12).

**WARNING:** Make sure the Q-latch is completely engaged at all times except when removing the display.

**NOTE:** A padlock may be used on the Q-latch for increased security.

5. Connect and secure power/audio/video cables.

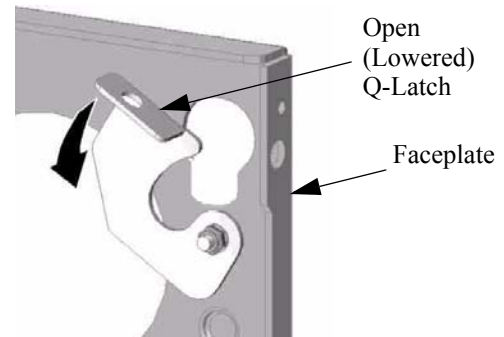

**FIGURE 10. OPEN Q-LATCH**

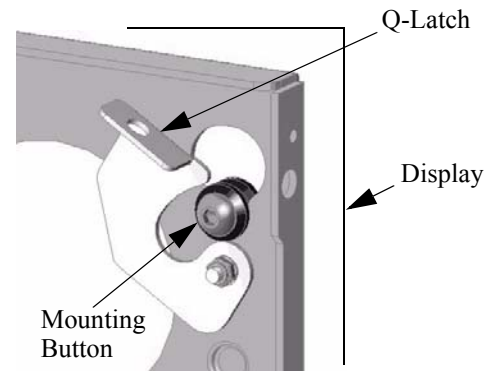

**FIGURE 11. MOUNT DISPLAY**

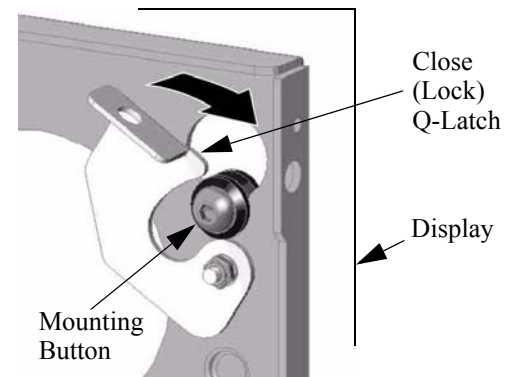

**FIGURE 12. CLOSE Q-LATCH**

## ROLL ADJUSTMENT

The Floor stand is designed to provide 2 degrees of roll adjustment of the display. Roll adjustment is accomplished by grabbing the display on each side and turning it right or left until display is level.

**NOTE:** Roll tension is preset at the factory. If the display is not level or does not remain in the desired position, perform the roll adjustment procedure.

To adjust roll tension, do the following:

1. Perform the procedure to "REMOVE THE DISPLAY" on page 8 for the purpose of gaining access to the roll tension adjustment nuts.
2. Locate roll adjustment nuts on back of face plate (see Figure 13).
3. As needed, partially loosen the roll adjustment nuts.
4. Level the faceplate by turning the faceplate clockwise up to 2 degrees or turning counterclockwise up to 2 degrees (see Figure 14).
5. Retighten the roll adjustment nuts (see Figure 13).
6. Perform the procedure to "MOUNT THE DISPLAY" on page 7.

## REMOVE THE DISPLAY

1. Disconnect power/audio/video cables.
2. Disengage (lower) the Q-latch.
3. With an assistant, lift the display from the PFB.

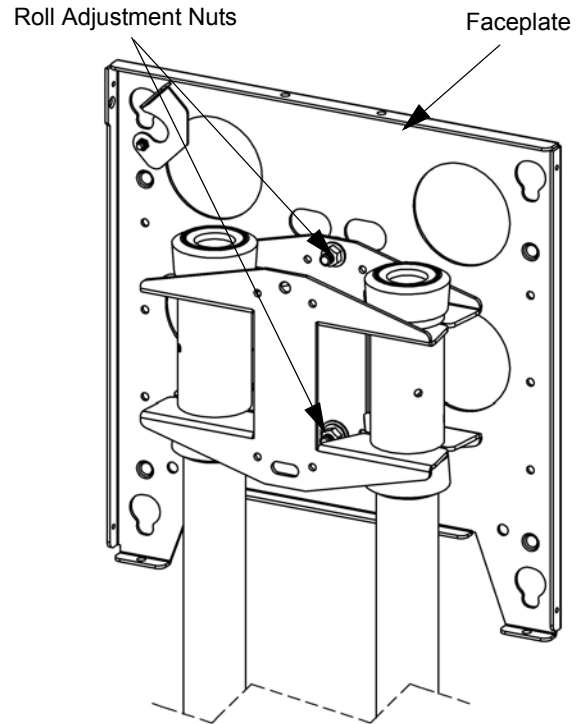

**FIGURE 13. ROLL ADJUSTMENT NUTS**

Level faceplate by turning 2 degrees CW or CCW

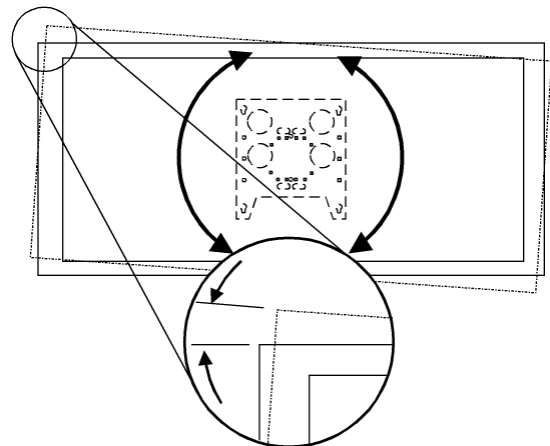

**FIGURE 14. LEVEL THE FACEPLATE**