

TO FIND HEIGHT REQUIRED ADD 5"
TO THE HEIGHT OF THE PLASMA BEING USED

REV	DESCRIPTION	DATE	CHK	AUTH

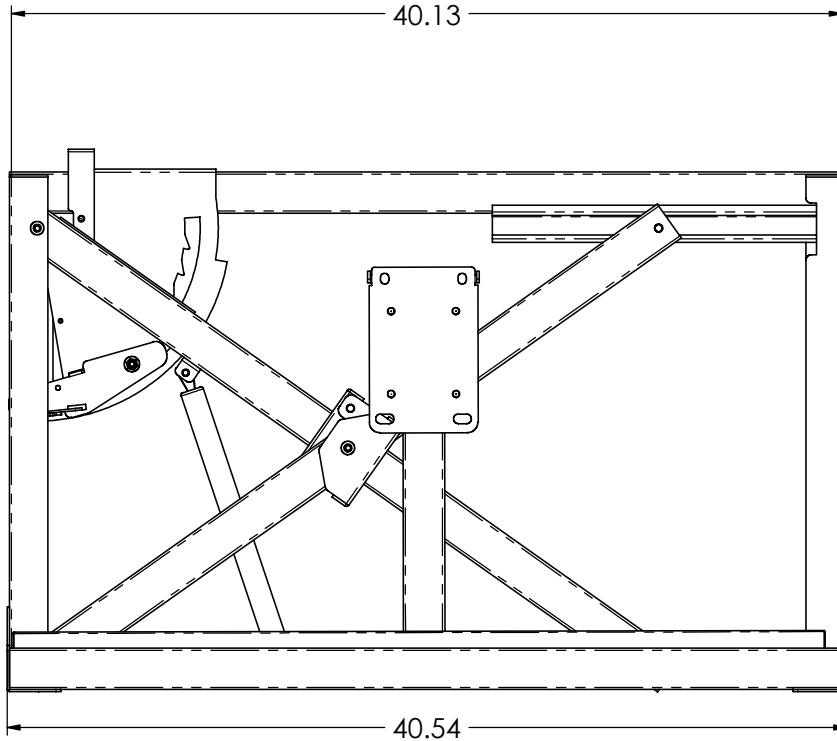

PDB BRACKET SLOTS REST
ON HOOKS ON MOUNT

BRACKET HEIGHT IS ADJUSTABLE
ALONG LENGTH OF TUBING

ADJUST PLASMA HEIGHT SUCH THAT
IT IS A MINIMUM OF .25" ABOVE TUBING

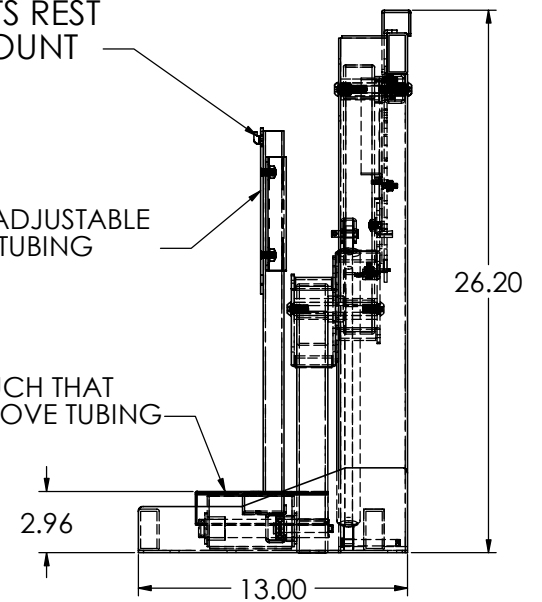

**THE INFORMATION AND DESIGNS CONTAINED
IN THIS DRAWING ARE CONFIDENTIAL AND THE
PROPRIETARY PROPERTY OF CHIEF MFG., INC.
NEITHER THIS DESIGN NOR ANY INFORMATION
CONTAINED IN THIS DRAWING MAY BE
REPRODUCED OR DISCLOSED TO OTHERS
WITHOUT THE EXPRESS WRITTEN CONSENT OF
CHIEF MFG., INC.**

THIRD ANGLE PROJECTION

DIMS. AND TOLERANCES PER
ASME Y14.5 - 1994

MATERIAL

FINISH

[X.XX] DIMENSIONS ARE IN mm XXX DIMENSIONS ARE IN INCHES	CAD GENERATED DRAWING. DO NOT MANUALLY UPDATE
UNLESS OTHERWISE NOTED TOLERANCES ARE:	DATE 03/13/01
[X] ± 2.5mm .X ± .100	DESIGNER J.A.B.
[X.X] ± .75mm .XX ± .030	DETAILER J.A.B.
[X.XX] ± .25mm .XXX ± .010	RESP ENG J.A.B.
[X.XXX] ± .13mm .XXXX ± .005	
ANGULAR: ± 0°30'	
SURFACE FINISH: 125 √	

DATE	03/13/01
DESIGNER	J.A.B.
DETAILER	J.A.B.
RESP ENG	J.A.B.
SHEET 1 OF 1	

CHIEF MANUFACTURING, INC.
12800 HWY 13 S., STE. 500 * SAVAGE, MN 55378
P 952-894-6280 * F 877-894-6918

**PLM
CUSTOMER DRAWING**

SIZE DWG. NO. **B**

REV.