

MODEL	"A" HEIGHT	USABLE DEPTH	NUMBER OF SELVES
WROTR-30B	29.5 [749mm]	18.75 [476mm]	3 SHELVES
WROTR-36B	35.5 [900mm]	18.75 [476mm]	4 SHELVES
WROTR-42B	41.5 [1050mm]	18.75 [476mm]	5 SHELVES

STATUS: LP 07/05/2012 - RELEASED ON ECO: 500006158

TECH-000077

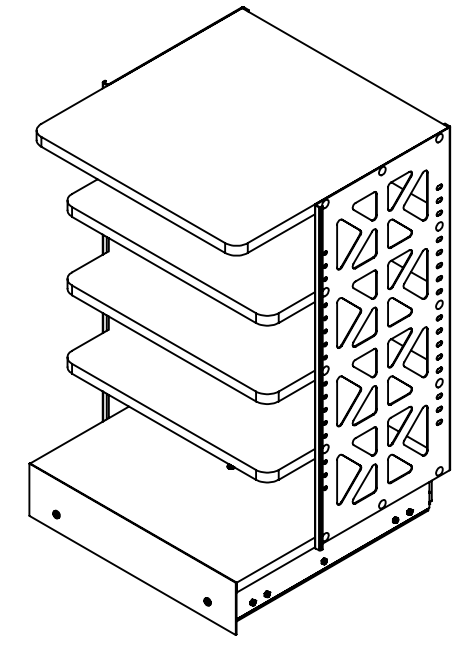
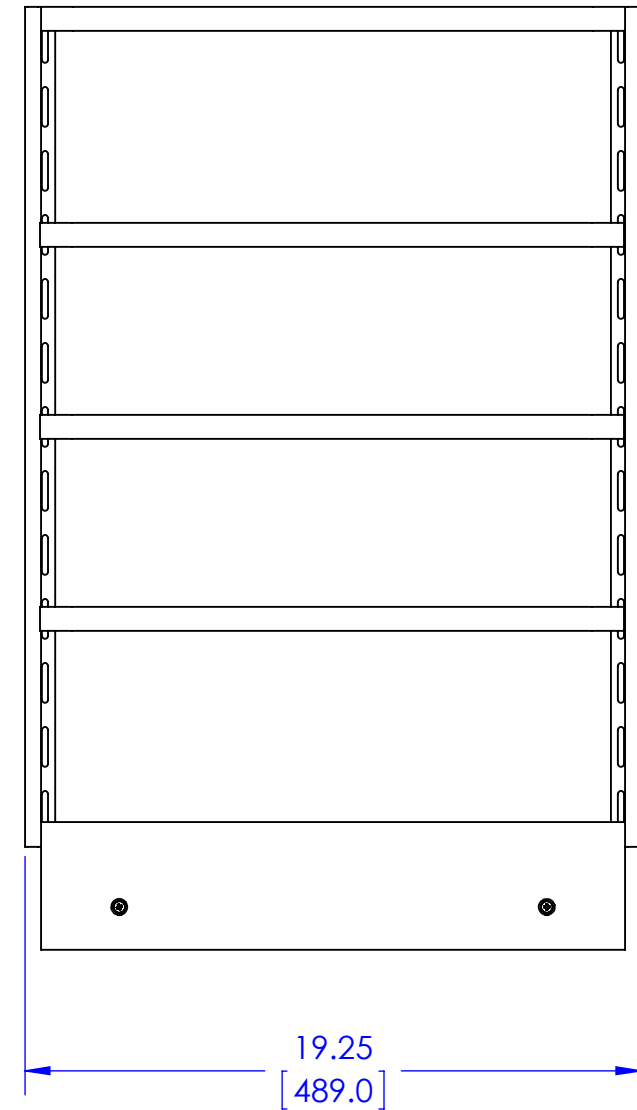
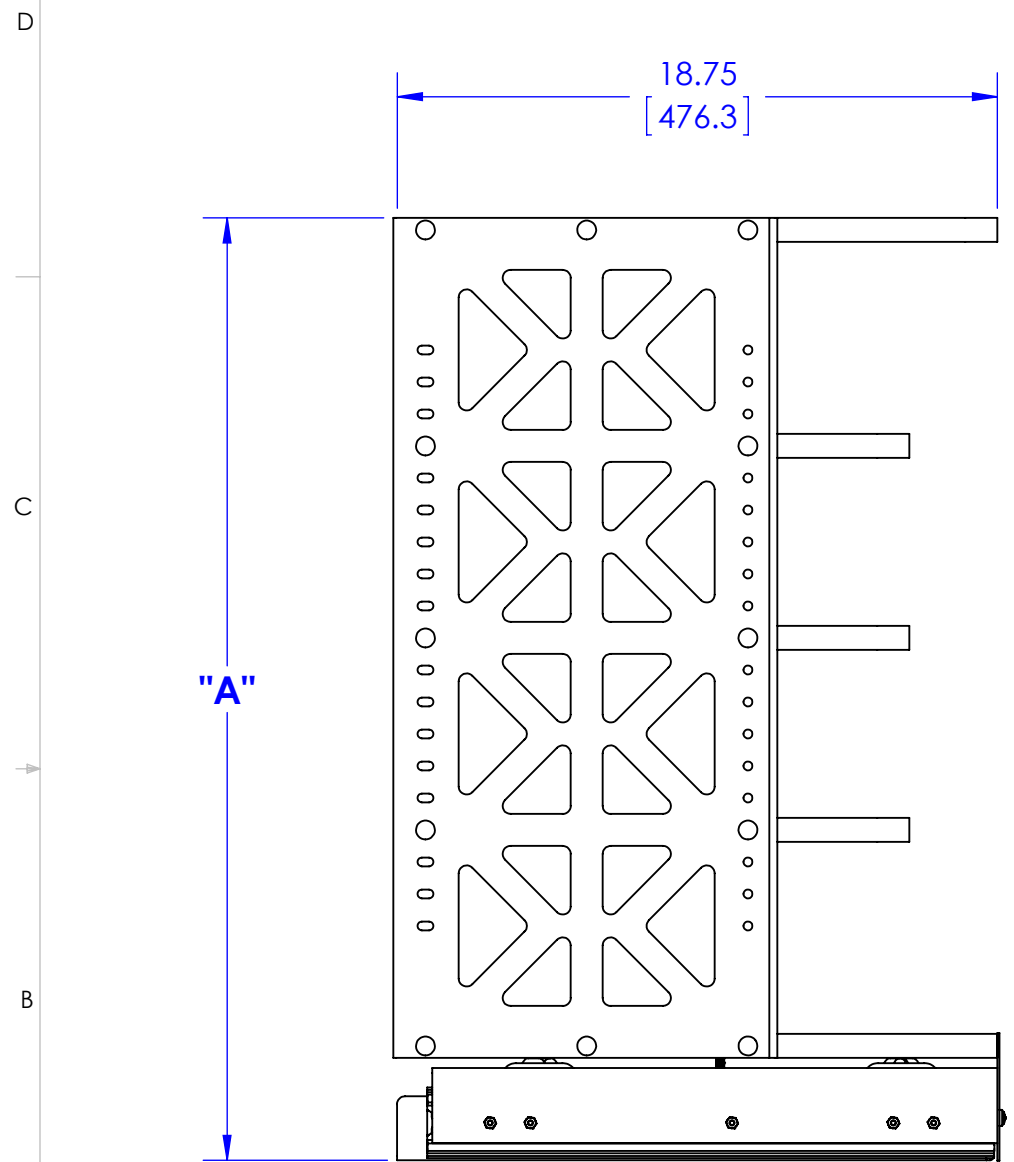

THE INFORMATION AND DESIGNS CONTAINED IN THIS DRAWING ARE CONFIDENTIAL AND THE PROPRIETARY PROPERTY OF MILESTONE AV TECHNOLOGIES NEITHER THIS DESIGN NOR ANY INFORMATION CONTAINED IN THIS DRAWING MAY BE REPRODUCED OR DISCLOSED TO OTHERS WITHOUT THE EXPRESS WRITTEN CONSENT OF MILESTONE AV TECHNOLOGIES.

CAD GENERATED DRAWING, DO NOT MANUALLY UPDATE.			6436 CITY WEST PKWY EDEN PRAIRIE MN, 55344 PHONE: 866-977-3901 FAX: 877-894-6918	
DRAWN BY	LRP	7/05/2012		
ENG APPROVAL	LRP	7/05/2012	DESCRIPTION WOOD ROTR SHELVES/TOP/BASE BLACK	
MFG APPROVAL			MODEL NO. W-ROTR	
QA APPROVAL			SIZE B	DWG. NO. TECH-000077
SHEET 1 OF 1			SCALE 1:12	REV. 00