



2801 Connery Way, Suite B
Missoula, MT 59808
Phn: (406) 541-EASE (3273) Fax: (406) 541-3274

Office of Statewide Health Planning and Development
ANCHORAGE PRE-APPROVAL

OPA-2347-07

Equipment Manufacturer: Chief Manufacturing Inc.

Equipment Type: WM2XX-T Projector Mount

GENERAL NOTES

1. FORCES PER ASCE 7-05 SECTION 13.3.1, EQUATIONS 13.3-1, 13.3-2 & 13.3-3, WHERE $S_{DS} = 1.93$, $a_p = 2.5$, $I_p = 1.5$ & $R_p = 2.5$
2. THIS PRE-APPROVAL CONFORMS TO THE 2007 CALIFORNIA BUILDING CODE.
3. THE DETAILS IN THIS PRE-APPROVAL MAY BE USED AT ANY LOCATION IN THE STATE OF CALIFORNIA.
THE ELEVATED FLOOR DETAILS MAY BE USED AT ANY HEIGHT IN A BUILDING.
4. ALL ANCHOR FORCES SHOWN ON THE DRAWINGS ARE WORKING LOADS (AS OPPOSED TO STRENGTH LEVEL LOADS) AND MAY BE USED FOR ALLOWABLE STRESS DESIGN.
5. PER CAN 2-1708A.5, THIS UNIT DOES NOT REQUIRE "SPECIAL SEISMIC CERTIFICATION".

RESPONSIBILITIES OF THE STRUCTURAL ENGINEER OF RECORD

6. DESIGN BACKING BARS, STUDS, ETC. WHICH THE UNITS ARE ATTACHED TO AS NOTED ON THE DRAWINGS.
THE SEOR SHALL ALSO VERIFY THE ADEQUACY OF THE STRUCTURES (SUCH AS WALLS AND FLOORS) WHICH SUPPORT THE UNITS FOR THE LOADS IMPOSED ON THEM BY THE UNITS AS WELL AS ALL OTHER LOADS.
7. PROVIDE ANY SUPPORTING STRUCTURE REQUIRED TO SUPPORT WEIGHTS AND FORCES SHOWN, IN ADDITION TO ALL OTHER LOADS.
8. VERIFY THAT THE INSTALLATION IS IN CONFORMANCE WITH THE 2007 CBC AND WITH THE DETAILS SHOWN IN THIS PRE-APPROVAL.
VERIFY THAT THE ACTUAL EQUIPMENT'S WEIGHT, CG LOCATION, ANCHOR LOCATIONS, ANCHOR DETAILS AND THE MATERIAL AND GAGE OF THE UNIT WHERE ATTACHMENTS ARE MADE AGREE WITH THE INFORMATION SHOWN ON THE PRE-APPROVAL DOCUMENTS.

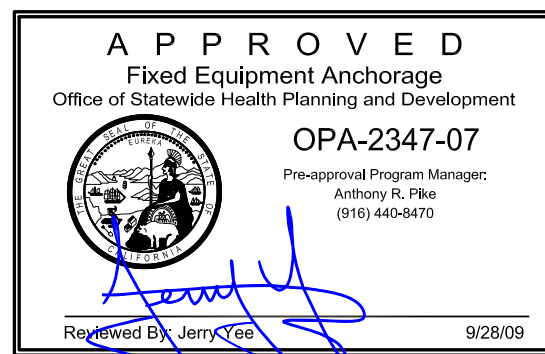

CHIEF MANUFACTURING INC.

WM2XX-T Projector Mount

DES. **R. LA BRIE**

EASE JOB NO. **11-0975**

DATE **9/28/09**

SHEET

2

OF **2** SHEETS

SEISMIC ANCHORAGE

WALL MOUNTED

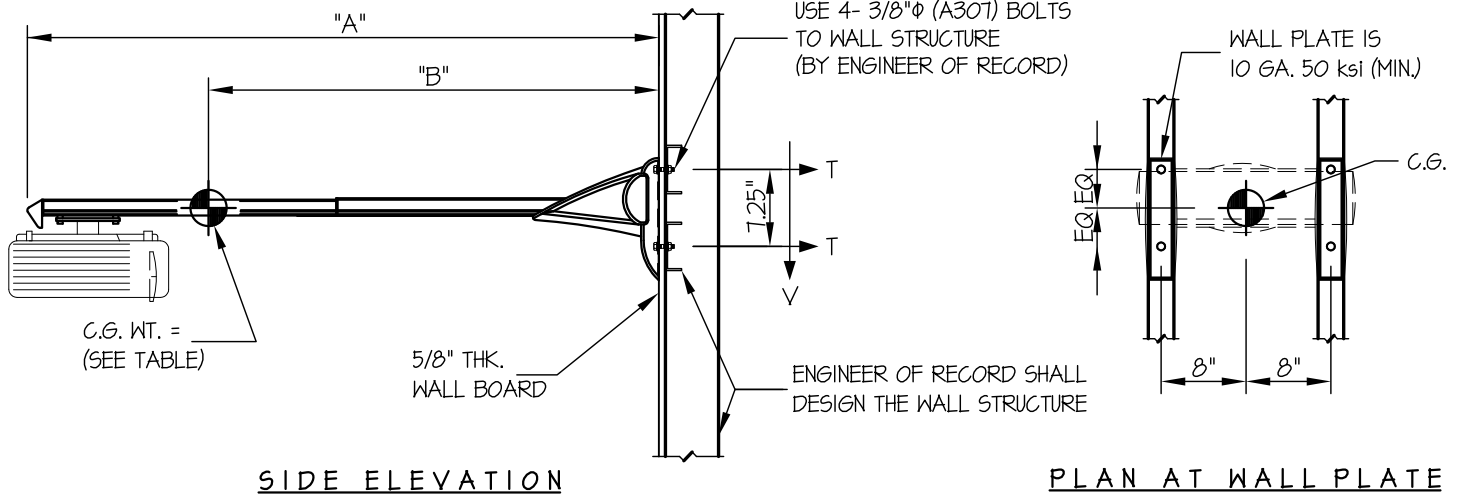

SIDE ELEVATION

PLAN AT WALL PLATE

MODEL NUMBER	WEIGHT (lbs.)	"A" (in.)	"B" (in.)	T _{MAX} (lbs.)	V _{MAX} (lbs.)
230S	46	34.1-59.6	42.7	324	43
220S	67	22.1-35.6	27.9	311	62
210S	65	15.9-23.1	17.3	193	60

NOTES:

1. ANCHORAGE DESIGN PER 2007 CALIFORNIA BUILDING CODE - SECTION 1613A AND ASCE 7-05 SECTIONS 12 AND 13. ALLOWABLE STRESS DESIGN IS USED.

HORIZONTAL FORCE (E_h) = $2.43 W_p$ ($S_d s = 1.93, a_p = 2.5, I_p = 1.5, R_p = 2.5$)

VERTICAL FORCE (E_v) = $0.27 W_p$

2. CENTER OF GRAVITY (C.G.) WEIGHT IS A MAXIMUM. THIS PRE-APPROVAL ENCOMPASSES ALL WEIGHTS UP TO THE MAXIMUM WEIGHT SHOWN.

3. ENGINEER OF RECORD FOR THE BUILDING SHALL PROVIDE SUPPORT STRUCTURE DESIGNED TO SUPPORT WEIGHTS AND FORCES SHOWN, IN ADDITION TO ALL OTHER LOADS.

4. SEE GENERAL NOTES: SHEET 1.

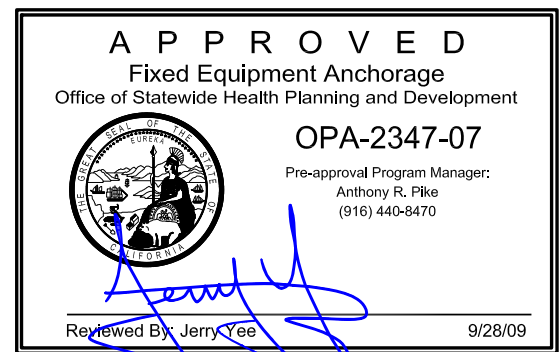

CHIEF MANUFACTURING INC.

WM2XX-T Projector Mount

DES. **R. LA BRIE**

EASE JOB NO. **11-0975**

DATE **8/24/09**

SHEET

1

OF **1** SHEETS

SEISMIC ANCHORAGE

WALL MOUNTED

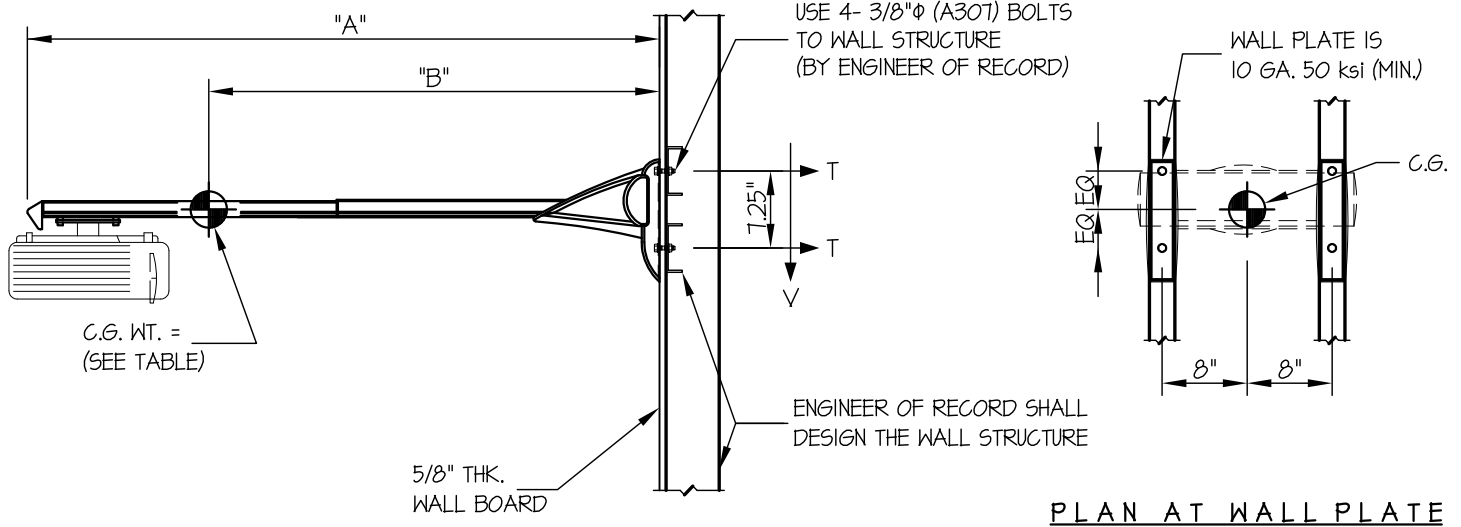

SIDE ELEVATION

PLAN AT WALL PLATE

LOADS: PER 2007 CALIFORNIA BUILDING CODE SECTION 1613A AND ASCE 7-05 SECTIONS 12 AND 13.

(ALLOWABLE STRESS DESIGN IS USED)

WEIGHT = 46 LBS. (INCLUDES PROJECTOR)

HORIZONTAL FORCE (E_h) = $2.43W_p$ = 112 LBS.

VERTICAL FORCE (E_v) = $0.27W_p$ = 12 LBS.

BOLT FORCES:

TENSION (T)

$$T_{\text{VERTICAL}} = \frac{(46\# + 12\#)(42.7")}{2 \text{ BOLTS } (7.25")} = 172 \text{ LBS}$$

$$T_{\text{PARALLEL}} = \frac{112\#(42.7")}{2 \text{ BOLTS } (16")} = 149 \text{ LBS}$$

$$T_{\text{PERP.}} = \frac{112\#}{4 \text{ BOLT}} = 28 \text{ LBS}$$

$$T_{\text{MAX}} = 172\# + \sqrt{149\#^2 + 28\#^2} = 324 \text{ LBS/BOLT (MAX)}$$

SHEAR (V)

$$V_{\text{MAX}} = \frac{46\# + 12\# + 112\#}{4 \text{ BOLT}} = 43 \text{ LBS/BOLT (MAX)}$$

MODEL NUMBER	WEIGHT (lbs.)	"A" (in)	"B" (in)	T _{MAX} (lbs.)	V _{MAX} (lbs.)
* 230S	46	34.1-59.6	42.7	324	43
220S	67	22.1-35.6	27.9	311	62
210S	65	15.9-23.1	17.3	193	60

* THIS UNIT USED IN CALCULATION.

NOTE:

ARCHITECT OR STRUCTURAL ENGINEER OF RECORD SHALL PROVIDE SUPPORT STRUCTURE TO SUPPORT WEIGHTS AND FORCES SHOWN.

